

# Series 2203

## 2.00mm PHD SMT Header Dual Row

### Material

Housing: High temp. plastic , UL94V-0  
 Color: Nature  
 Contact: Brass

### Electrical

Current rating: 3.0 Amp  
 Voltage rating: 250 V AC/DC  
 Contact resistance: 20 mΩ max.  
 Insulator resistance: 1000 MΩ min.  
 Dielectrical withstanding: 800 VAC/minute  
 Operating temperature: -25°C ~ +85°C

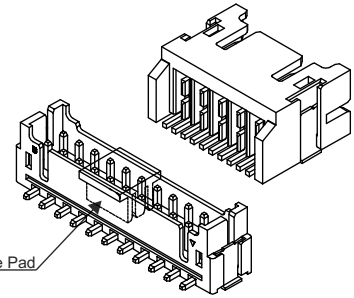

Pick & Place Pad

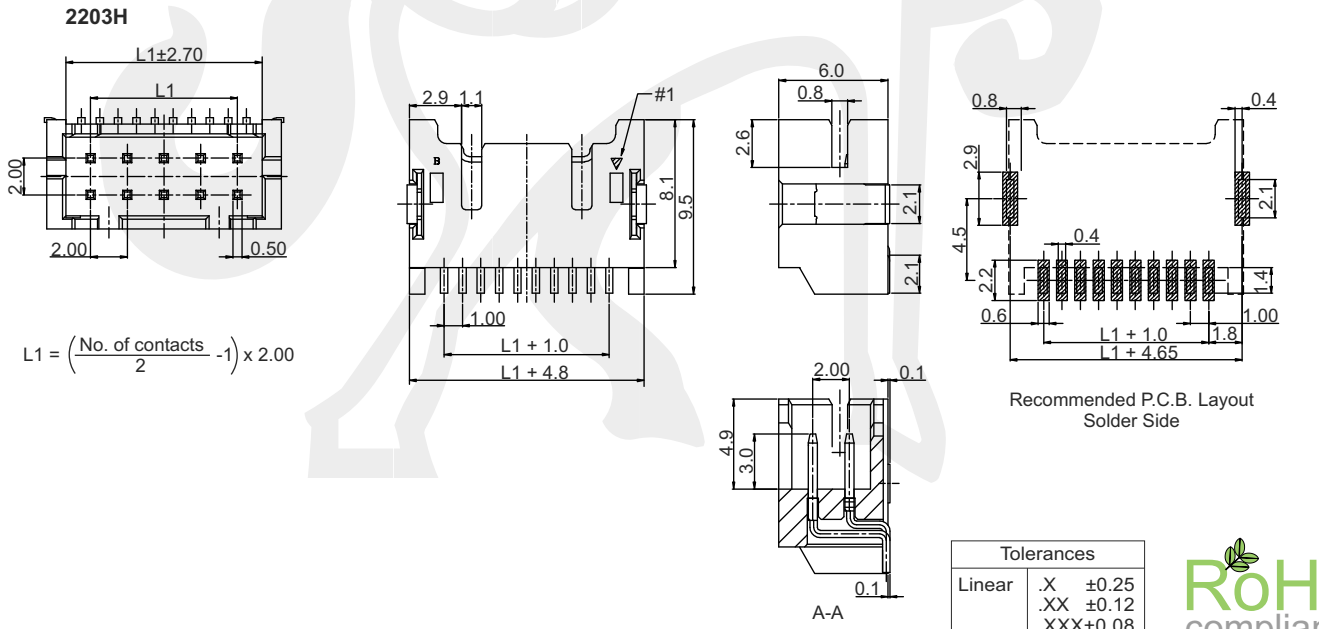
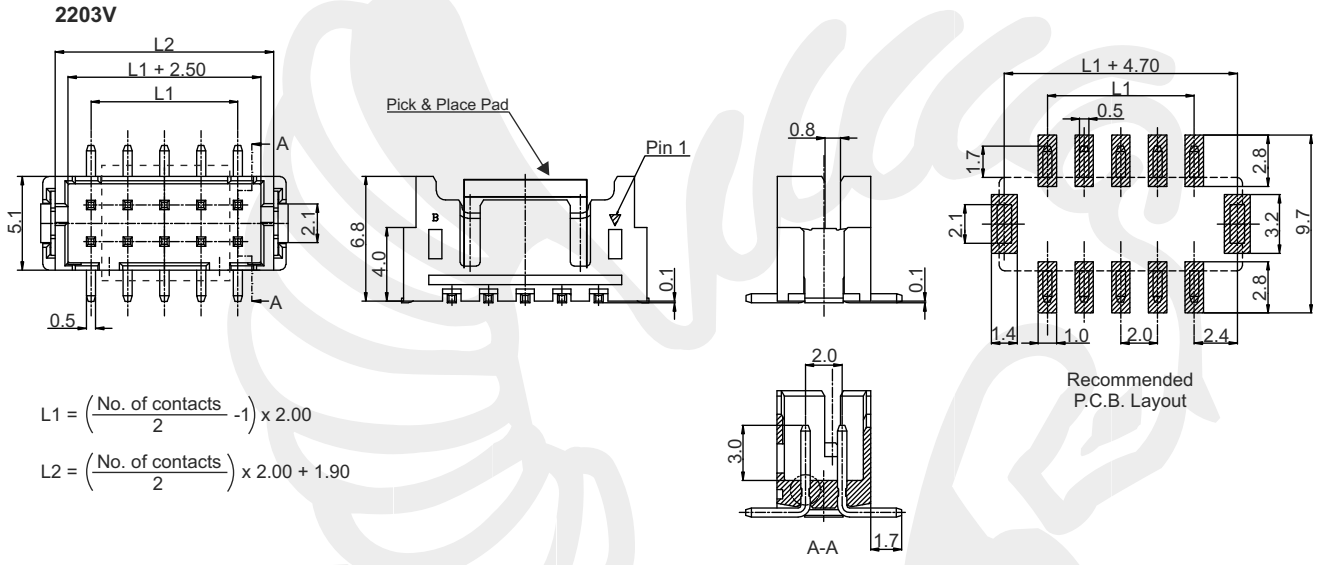

Tolerances	
Linear	X ±0.25
	.XX ±0.12
	.XXX±0.08



All dim. in mm

<b>2203 V</b>	<b>10</b>	<b>T</b>	<b>R</b>
Series V = SMT vertical H = SMT horizontal	No. of contacts 10 ~ 40	Plating T = tin other plating on customer request	Packing R = Reel