

**FAST RECOVERY RECTIFIER DIODES**

- FAST RECOVERY TIME
- LOW FORWARD RECOVERY TIME
- AVAILABLE UP TO 600V

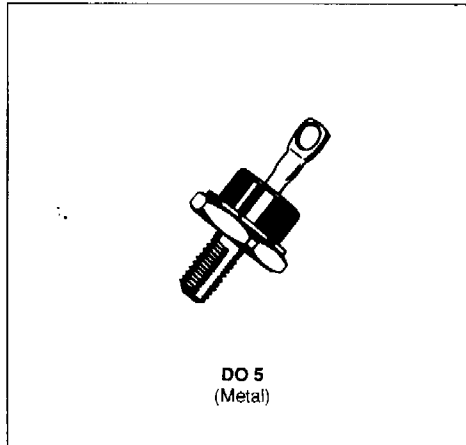

**APPLICATIONS**

- DC AND AC MOTOR CONTROL
- SWITCHMODE POWER SUPPLY
- HIGH FREQUENCY CHOPPERS
- HIGH FREQUENCY RECTIFIERS

**ABSOLUTE RATINGS** (limiting values)

Symbol	Parameter	Value	Unit
$I_{FRM}$	Repetitive Peak Forward Current $t_p \leq 20\mu s$	200	A
$I_{F(AV)}$	Average Forward Current $T_C = 100^\circ C$	20	A
$I_{FSM}$	Surge non Repetitive Forward Current $t_p = 10ms$ Sinusoidal	225	A
$P_{tot}$	Power Dissipation $T_C = 100^\circ C$	35	W
$T_{stg}$ $T_J$	Storage and Junction Temperature Range	- 65 to 150	$^\circ C$

Symbol	Parameter	1N					BYX 63-600	Unit
		3899	3900	3901	3902	3903		
$V_{RRM}$	Repetitive Peak Reverse Voltage	50	100	200	300	400	600	V

**THERMAL RESISTANCE**

Symbol	Parameter	Value	Unit
$R_{th(j-c)}$	Junction-case	1.5	$^\circ C/W$

**ELECTRICAL CHARACTERISTICS**

**STATIC CHARACTERISTICS**

Symbol	Test Conditions	Min.	Typ.	Max.	Unit
$I_R$	$T_J = 25^\circ C$ $V_R = V_{RRM}$			50	$\mu A$
	$T_J = 100^\circ C$			6	mA
$V_F$	$T_J = 25^\circ C$ $I_F = 20A$			1.4	V

**RECOVERY CHARACTERISTICS**

Symbol	Test Conditions	Min.	Typ.	Max.	Unit
$t_{rr}$	$T_J = 25^\circ C$ $V_R = 30V$ $I_F = 1A$ $di_F/dt = - 15A/\mu s$			200	ns
$Q_{rr}$	$T_J = 25^\circ C$ $V_R = 30V$ $I_F = 1A$ $di_F/dt = - 15A/\mu s$			0.3	$\mu C$
$I_{RM}$	$T_J = 25^\circ C$ $V_R = 30V$ $I_F = 1A$ $di_F/dt = - 15A/\mu s$			3	A



To evaluate the conduction losses use the following equations :

$$V_F = 1.2 + 0.008 I_F \quad P = 1.2 \times I_{F(AV)} + 0.008 I_{F(RMS)}^2$$