

EMC-Power Line Filters for 1-Phase Systems

FPP Series, industrial-mains-filters to Protection Class I, conform to EN 133200, UL 1283 and IEC 60950

Nominal current: 0.5 – 6.5 A @ 40 °C
 Rated voltage U_R (U_{max}): 125/250 VAC 50/60 Hz
 Attenuation: Standard
 Leakage current: for Standard and Medical applications
 Test voltages: L/N → E 2.7 kVDC, 2 sec
 L → N 1.7 kVDC, 2 sec *
 Climatic category: 25/085/21 acc. to IEC 60068-1
 50% saturation typ.: 2 to 3 x I_N @ 20 °C
 Inrush current: 1.5 x I_N 1 min. per hour
 MTBF @ 40 °C / U_R (U_{max}): > 200'000 h acc. To MIL-HB-217 F
 Plastic case: UL 94 V-0
 Potting compound: UL 94 V-0

* without resistor

Approvals:



A large program of various filter types with regard to nominal voltage, rated current, number of phases and type of connection is available. They are all in accordance with the international standards of the radio interference filters like e.g. EN 133200.

The simple construction of the plastic filters with solder pins for PCB mounting is mainly suitable for later installation in the case of interference.



Interference suppression filter in plastic housing are low-priced suppressors, active over a large frequency range.

Provided that the right type of filter is selected, a double-faced effect can be achieved, namely from the apparatus outwards as noise suppression filter and in the other direction as power-transient-protective-filter.

Optional versions:

- Versions with quick connect terminal or added wire connections
- Medical version M80 with leakage current < 80 μ A

Contact Schurter for minimum order quantity

Order Numbers and Technical Data

Type FPP	I_N (1)	U_R	L_N (2)	Leakage current (3)	Co/C2(X2)	C1(Y2)	R	Circuit diagram	Case	
Standard	@ ϑ_a 40 °C [A]	(U_{max}) [VAC]	-30% / +50% [mH]	@ 250 V / 50 Hz [mA]	[μ F]	[nF]	[M Ω]			
SQUARE	5500.2000	0.6	2 x 40	< 0.25	0.015	2.2	-	S1	13P	
	5500.2001	1	2 x 10	< 0.25	0.015	2.2	-	S1	13P	
	5500.2002	2	2 x 4	< 0.25	0.015	2.2	-	S1	13P	
	5500.2003	4	2 x 1.5	< 0.25	0.015	2.2	-	S1	13P	
	5500.2004	6	2 x 0.8	< 0.25	0.015	2.2	-	S1	13P	
	5500.2005	0.7	250	2 x 40	< 0.25	0.015	2.2	-	S1	18P
	5500.2006	1	250	2 x 20	< 0.25	0.022	2.2	-	S1	18P
	5500.2007	2	250	2 x 6	< 0.25	0.022	2.2	-	S1	18P
	5500.2008	3	250	2 x 3	< 0.25	0.022	2.2	-	S1	18P
	5500.2009	1	250	2 x 30	< 0.25	0.047	2.2	-	S1	24P
5500.2010	3	250	2 x 4	< 0.25	0.047	2.2	-	S1	24P	
RECTANGULAR	5500.2014	0.5	2 x 40	< 0.25	0.1	2.2	-	S2	27P	
	5500.2015	1.0	2 x 10	< 0.25	0.1	2.2	-	S2	27P	
	5500.2016	1.6	2 x 6	< 0.25	0.1	2.2	-	S2	27P	
	5500.2017	2.5	250	2 x 2	< 0.25	0.1	2.2	-	S2	27P
	5500.2018	4	250	2 x 1	< 0.25	0.1	2.2	-	S2	27P
	5500.2019	6.5	250	2 x 1	< 0.25	0.1	2.2	-	S2	27P
	5500.2020	0.8	250	2 x 20	< 0.25	0.068/0.015	2.2	-	S3	27-1P
	SQUARE	5500.2116	0.6	2 x 40	< 5	0.015	-	1	S1	13P
		5500.2117	1	2 x 10	< 5	0.015	-	1	S1	13P
		5500.2118	2	2 x 4	< 5	0.015	-	1	S1	13P
5500.2119		4	2 x 1.5	< 5	0.015	-	1	S1	13P	
5500.2120		6	2 x 0.8	< 5	0.015	-	1	S1	13P	
5500.2121		0.7	250	2 x 40	< 5	0.015	-	1	S1	18P
5500.2122		1	250	2 x 20	< 5	0.022	-	1	S1	18P
5500.2123		2	250	2 x 6	< 5	0.022	-	1	S1	18P
5500.2124		3	250	2 x 3	< 5	0.022	-	1	S1	18P
5500.2125		1	250	2 x 30	< 5	0.047	-	1	S1	24P
5500.2126		3	250	2 x 4	< 5	0.047	-	1	S1	24P
5500.2127		0.5	250	2 x 40	< 5	0.1	-	1	S2	27P
5500.2130		1.0	250	2 x 10	< 5	0.1	-	1	S2	27P
5500.2131		1.6	250	2 x 6	< 5	0.1	-	1	S2	27P
5500.2132		2.5	250	2 x 2	< 5	0.1	-	1	S2	27P
5500.2133		4	250	2 x 1	< 5	0.1	-	1	S2	27P
5500.2128		6.5	250	2 x 1	< 5	0.1	-	1	S2	27P
5500.2129		0.8	250	2 x 20	< 5	0.068/0.015	-	1	S3	27-1P
RECTANGULAR		5500.2116	0.6	2 x 40	< 5	0.015	-	1	S1	13P
	5500.2117	1	2 x 10	< 5	0.015	-	1	S1	13P	
	5500.2118	2	2 x 4	< 5	0.015	-	1	S1	13P	
	5500.2119	4	2 x 1.5	< 5	0.015	-	1	S1	13P	
	5500.2120	6	2 x 0.8	< 5	0.015	-	1	S1	13P	
	5500.2121	0.7	250	2 x 40	< 5	0.015	-	1	S1	18P
	5500.2122	1	250	2 x 20	< 5	0.022	-	1	S1	18P
	5500.2123	2	250	2 x 6	< 5	0.022	-	1	S1	18P
	5500.2124	3	250	2 x 3	< 5	0.022	-	1	S1	18P
	5500.2125	1	250	2 x 30	< 5	0.047	-	1	S1	24P
	5500.2126	3	250	2 x 4	< 5	0.047	-	1	S1	24P
	5500.2127	0.5	250	2 x 40	< 5	0.1	-	1	S2	27P
	5500.2130	1.0	250	2 x 10	< 5	0.1	-	1	S2	27P
	5500.2131	1.6	250	2 x 6	< 5	0.1	-	1	S2	27P
	5500.2132	2.5	250	2 x 2	< 5	0.1	-	1	S2	27P
	5500.2133	4	250	2 x 1	< 5	0.1	-	1	S2	27P
	5500.2128	6.5	250	2 x 1	< 5	0.1	-	1	S2	27P
	5500.2129	0.8	250	2 x 20	< 5	0.068/0.015	-	1	S3	27-1P

(1) Current derating over 40°C : $I = I_N \times \sqrt{(85 - \vartheta_a)/45}$

(2) Nominal inductance measured according to EN 138100, see introduction of this catalog, paragraph 3.4

(3) Measured according to IEC 60950 5.2.3 Annex D, see introduction of this catalog, paragraph 3.5

EMC-Power Line Filters for 1-Phase Systems

FPP Series, circuit diagrams, cases

S1 Circuit diagram

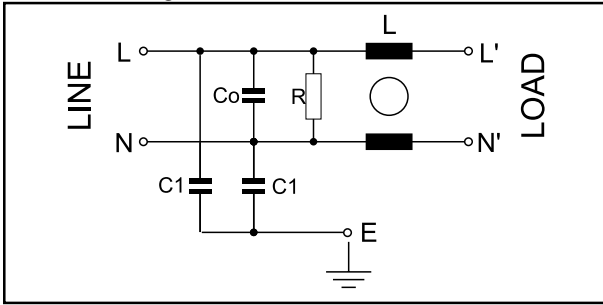

S3 Circuit diagram

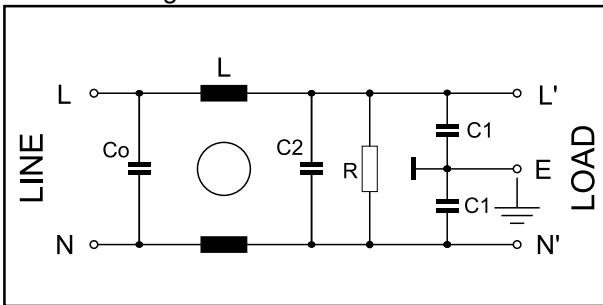

S2 Circuit diagram

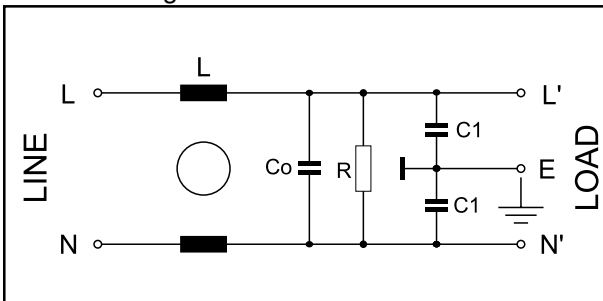

Case 13P / 18P / 24P

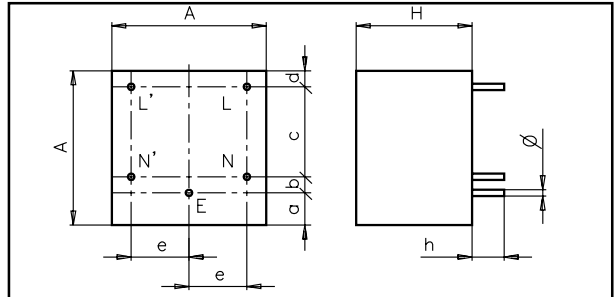

Case	A [mm]	H [mm]	a [mm]	b [mm]	c [mm]	d [mm]	e [mm]	h [mm]	Ø [mm]
13P	25	25	5	2.5	15	2.5	10	4.5 ± 0.5	0.6
18P	30	25	7.5	2.5	15	5	10	4.5 ± 0.5	0.6
24P	40	30	10	5	20	5	15	4.5 ± 0.5	1.0

Case 27P

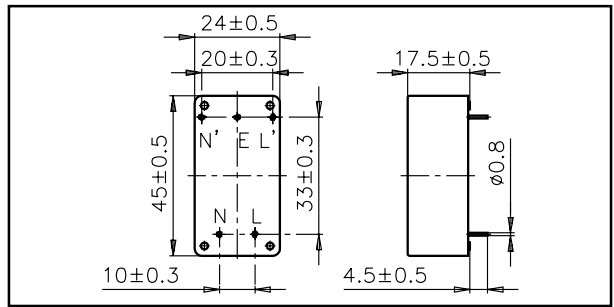

Case 27-1P

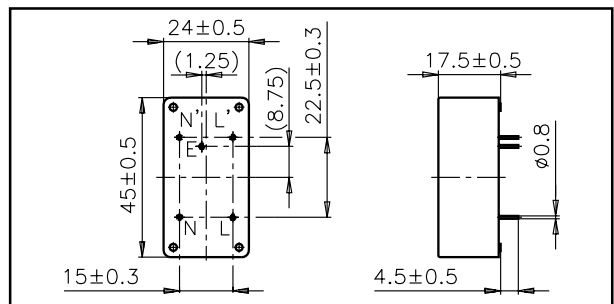

EMC-Power Line Filters for 1-Phase Systems

FPP Series, insertion loss - Standard

SQUARE

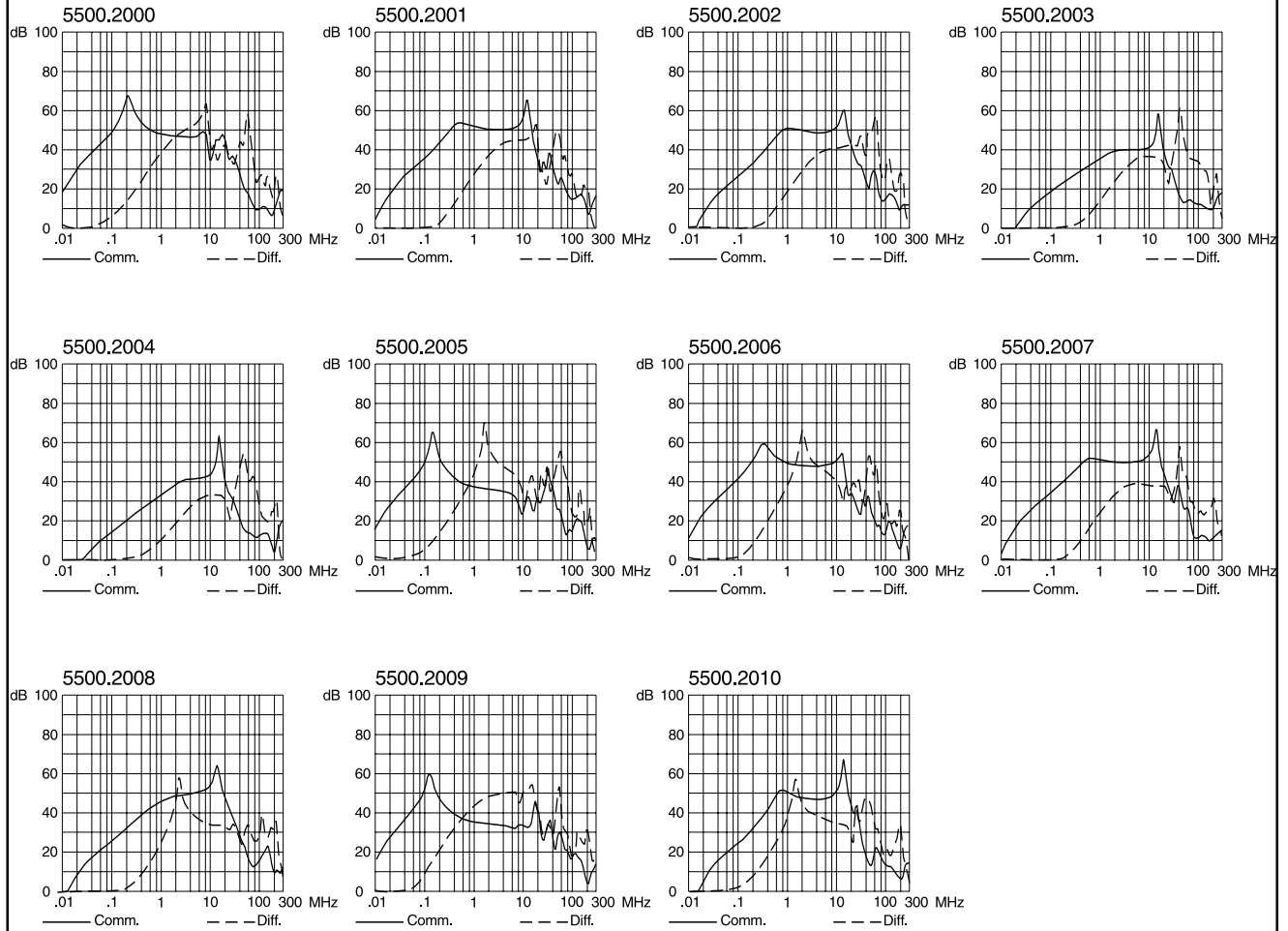

RECTANGULAR

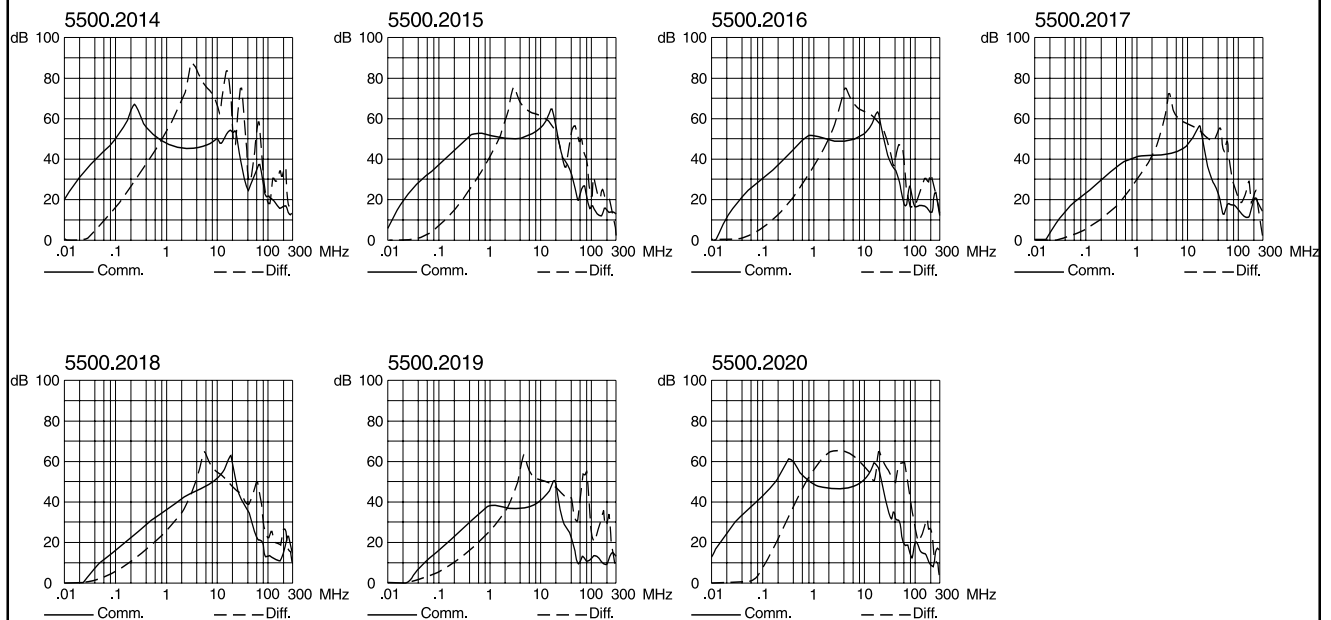

EMC-Power Line Filters for 1-Phase Systems

FPP Series, insertion loss - Medical M5

SQUARE

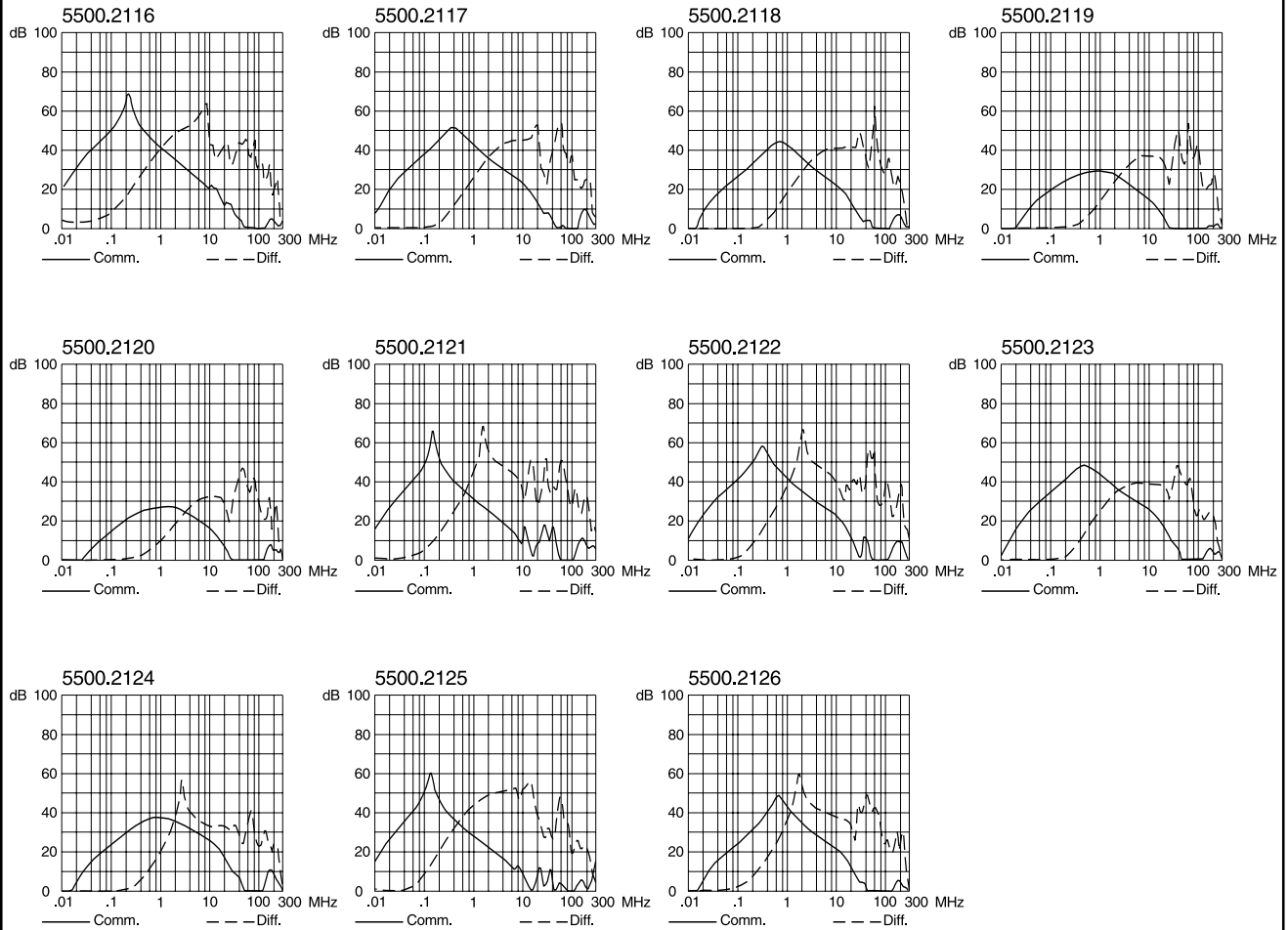

RECTANGULAR

