

Aluminum Electrolytic Capacitors

Products Catalog

Surface Mount Type



Guidelines and precautions regarding the technical information and use of our products described in this online catalog.

- If you want to use our products described in this online catalog for applications requiring special qualities or reliability, or for applications where the failure or malfunction of the products may directly jeopardize human life or potentially cause personal injury (e.g. aircraft and aerospace equipment, traffic and transportation equipment, combustion equipment, medical equipment, accident prevention, anti-crime equipment, and/or safety equipment), it is necessary to verify whether the specifications of our products fit to such applications. Please ensure that you will ask and check with our inquiry desk as to whether the specifications of our products fit to such applications use before you use our products.
- The quality and performance of our products as described in this online catalog only apply to our products when used in isolation. Therefore, please ensure you evaluate and verify our products under the specific circumstances in which our products are assembled in your own products and in which our products will actually be used.
- If you use our products in equipment that requires a high degree of reliability, regardless of the application, it is recommended that you set up protection circuits and redundancy circuits in order to ensure safety of your equipment.
- The products and product specifications described in this online catalog are subject to change for improvement without prior notice. Therefore, please be sure to request and confirm the latest product specifications which explain the specifications of our products in detail, before you finalize the design of your applications, purchase, or use our products.
- The technical information in this online catalog provides examples of our products' typical operations and application circuits. We do not guarantee the non-infringement of third party's intellectual property rights and we do not grant any license, right, or interest in our intellectual property.
- If any of our products, product specifications and/or technical information in this online catalog is to be exported or provided to non-residents, the laws and regulations of the exporting country, especially with regard to security and export control, shall be observed.

<Regarding the Certificate of Compliance with the EU RoHS Directive/REACH Regulations>

- The switchover date for compliance with the RoHS Directive/REACH Regulations varies depending on the part number or series of our products.
- When you use the inventory of our products for which it is unclear whether those products are compliant with the RoHS Directive/REACH Regulation, please select "Sales Inquiry" in the website inquiry form and contact us.

We do not take any responsibility for the use of our products outside the scope of the specifications, descriptions, guidelines and precautions described in this online catalog.

Notices

■ Applicable laws and regulations

- This product complies with the RoHS Directive (Restriction of the use of certain hazardous substances in electrical and electronic equipment (DIRECTIVE 2011/65/EU and (EU)2015/863)).
- No Ozone Depleting Chemicals(ODC's), controlled under the Montreal Protocol Agreement, are used in producing this product.
We do not use PBBs or PBDEs as brominated flame retardants.
- Export procedure which followed export related regulations, such as foreign exchange and a foreign trade method, on the occasion of export of this product.
- These products are not dangerous goods on the transportation as identified by UN(United Nations) numbers or UN classification.

■ Limited applications

- This capacitor is designed to be used for electronics circuits such as audio/visual equipment, home appliances, computers and other office equipment, optical equipment, measuring equipment.
- High reliability and safety are required [be / a possibility that incorrect operation of this product may do harm to a human life or property] more. When use is considered by the use, the delivery specifications which suited the use separately need to be exchanged.

■ Intellectual property rights and licenses

- The technical information in this specification provides examples of our products' typical operations and application circuits. We do not guarantee the non-infringement of third party's intellectual property rights and we do not grant any license, right, or interest in our intellectual property.

Items to be observed

■ For specification

- This specification guarantees the quality and performance of the product as individual components. The durability differs depending on the environment and the conditions of usage. Before use, check and evaluate their compatibility with actual conditions when installed in the products. When safety requirements cannot be satisfied in your technical examination, inform us immediately.
- Do not use the products beyond the specifications described in this document.

■ Upon application to products where safety is regarded as important

Install the following systems for a failsafe design to ensure safety if these products are to be used in equipment where a defect in these products may cause the loss of human life or other signification damage, such as damage to vehicles (automobile, train, vessel), traffic lights, medical equipment, aerospace equipment, electric heating appliances, combustion/ gas equipment, rotating rotating equipment, and disaster/crime prevention equipment.

- (1) The system is equipped with a protection circuit and protection device.
- (2) The system is equipped with a redundant circuit or other system to prevent an unsafe status in the event of a single fault.

■ Conditions of use

- Before using the products, carefully check the effects on their quality and performance, and determined whether or not they can be used. These products are designed and manufactured for general-purpose and standard use in general electronic equipment. These products are not intended for use in the following special conditions.
 - (1) In liquid, such as Water, Oil, Chemicals, or Organic solvent.
 - (2) In direct sunlight, outdoors, or in dust.
 - (3) In vapor, such as dew condensation water of resistive element, or water leakage, salty air, or air with a high concentration corrosive gas, such as Cl₂, H₂S, NH₃, SO₂, or NO_x.
 - (4) In an environment where strong static electricity or electromagnetic waves exist.
 - (5) Mounting or placing heat-generating components or inflammables, such as vinyl-coated wires, near these products.
 - (6) Sealing or coating of these products or a printed circuit board on which these products are mounted, with resin and other material.
 - (7) Using solvent, water or water-soluble cleaner for flux cleaning agent after soldering. (In particular, when using water or a water-soluble cleaning agent, be careful not to leave water residues)
 - (8) Using in the atmosphere where strays acid or alkaline.
 - (9) Using in the atmosphere where there are excessive vibration and shock.
- Please arrange circuit design for preventing impulse or transitional voltage.
Do not apply voltage, which exceeds the full rated voltage when the capacitors receive impulse voltage, instantaneous high voltage, high pulse voltage etc.
- Our products there is a product are using an electrolyte solution. Therefore, misuse can result in rapid deterioration of characteristics and functions of each product. Electrolyte leakage damages printed circuit and affects performance, characteristics, and functions of customer system.

⚠ Application guidelines (SMD Type)

1. Circuit design

1.1 Operating temperature and frequency

Electrical characteristics of the capacitor are likely to change due to variation in temperature and/or frequency. Circuit designers should take these changes into consideration.

(1) Effects of operating temperature on electrical parameters

At higher temperatures : leakage current and capacitance increase while equivalent series resistance (ESR) decreases.

At lower temperatures : leakage current and capacitance decrease while equivalent series resistance (ESR) increases.

(2) Effects of frequency on electrical parameters

At higher frequencies : capacitance and impedance decrease while tan δ increases.

At lower frequencies : heat generated by ripple current will rise due to an increase in equivalent series resistance (ESR).

1.2 Operating temperature and life expectancy

(1) Expected life is affected by operating temperature. Generally, each 10 °C reduction in temperature will double the expected life. Use capacitors at the lowest possible temperature below the upper category temperature.

(2) If operating temperatures exceed the upper category limit, rapid deterioration of electrical parameter will occur and irreversible damage will result.

Check for the maximum capacitor operating temperatures including ambient temperature, internal capacitor temperature rise due to ripple current, and the effects of radiated heat from power transistors, IC's or resistors.

Avoid placing components, which could conduct heat to the capacitor from the back side of the circuit board.

(3) The formula for calculating expected life at lower operating temperatures is as follows ;

$$L_2 = L_1 \times 2^{\frac{T_1 - T_2}{10}}$$

L₁ : Guaranteed life (h) at temperature, T₁ °C

L₂ : Expected life (h) at temperature, T₂ °C

T₁ : Upper category temperature (°C)

T₂ : Actual operating temperature, ambient temperature + temperature rise due to ripple current (°C)

(4) Using the capacitor beyond the estimated lifetime will result in short circuit, electrolyte leak, vent open, and large deterioration of characteristics. The lifetime cannot go above 15 years due to aging of sealing rubber.

1.3 Common application conditions to avoid

The following misapplication load conditions will cause rapid deterioration of a capacitor's electrical parameters.

In addition, rapid heating and gas generation within the capacitor can occur, causing the pressure relief vent to operate and resultant leakage of electrolyte. Under extreme conditions, explosion and fire ignition could result. The leaked electrolyte is combustible and electrically conductive.

(1) Reverse voltage

DC capacitors have polarity. Therefore, please do not apply the reverse voltage. Verify correct polarity before insertion.

For circuits with changing or uncertain polarity, use DC bipolar capacitors. DC bipolar capacitors are not suitable for use in AC circuits.

(2) Charge / Discharge applications

Standard capacitors are not suitable for use in repeating charge/discharge applications. For charge/discharge applications, consult us with your actual application condition.

For rush current, please do not exceed 100 A.

(3) ON-OFF circuit

Do not use capacitors in circuit where ON-OFF switching is repeated more than 10000 times/per day.

In case of applying to theses ON-OFF circuit, consult with us about circuit condition and so on.

(4) Over voltage

Do not apply voltages exceeding the maximum specified rated voltage. Voltages up to the surge voltage rating are acceptable for short periods of time.

Ensure that the sum of the DC voltage and the superimposed AC ripple voltage does not exceed the rated voltage.

(5) Ripple current

Do not apply ripple currents exceeding the maximum specified value. For high ripple current applications, use a capacitor designed for high ripple currents. In addition, consult us if the applied ripple current is to be higher than the maximum specified value. Ensure that rated ripple currents that superimposed on low DC bias voltages do not cause reverse voltage conditions.

Even if it is within a rated ripple current, in case the practical use is over the pre described endurance lifetime, it causes the increase of deterioration of ESR characteristic and the internal generation heat by ripple current. Due to this, there is some possibility of vent open, bulging of sleeve and rubber, electrolyte leakage, and shot circuit, explosion and ignition in the worst case.

1.4 Using two or more capacitors in parallel

(1) Capacitors connected in parallel

The circuit resistance can closely approximate the series resistance of the capacitor, causing an imbalance of ripple current loads within the capacitors. Careful wiring methods can minimize the possible application of an excessive ripple current to a capacitor.

(2) Capacitors connected in series

Differences in normal DC leakage current among capacitors can cause voltage imbalances.

The use of voltage divider shunt resistors with consideration to leakage currents can prevent capacitor voltage imbalances.

NOTE : Please do not use in the series in the case of conductive polymer hybrid aluminum electrolytic capacitor.

1.5 Capacitor mounting considerations

(1) Double-sided circuit boards

Avoid wiring pattern runs, which pass between the mounted capacitor and the circuit board.

(2) Clearance for case mounted pressure relief ($\geq \varnothing 10$ mm)

Capacitors with case mounted pressure relief require sufficient clearance to allow for proper pressure relief operation.

The minimum clearance are dependent on capacitor diameters as follows.

(Dia 10 mm to Dia 16 mm : 2 mm minimum, Dia 18 mm : 3 mm minimum)

(3) Wiring near the pressure relief ($\geq \varnothing 10$ mm)

Avoid locating high voltage or high current wiring or circuit board paths above the pressure relief.

Flammable, high temperature gas that exceeds 100 °C may be released which could dissolve the wire insulation and ignite.

(4) Circuit board patterns under the capacitor

Avoid circuit board runs under the capacitor, as an electrical short can occur due to an electrolyte leakage.

1.6 Electrical isolation of the capacitor

Completely isolate the capacitor as follows.

- Between the cathode and the case and between the anode terminal and other circuit paths.

1.7 Capacitor coating

The laminate coating is intended for marking and identification purposes and is not meant to electrically insulate the capacitor.

2. Capacitor handling techniques

2.1 Considerations before using

(1) Capacitors have a finite life. Do not reuse or recycle capacitors from used equipment.

(2) Transient recovery voltage may be generated in the capacitor due to dielectric absorption.

If required, this voltage can be discharged with a resistor with a value of about 1 k Ω .

(3) Capacitors stored for a long period of time may exhibit an increase in leakage current.

This can be corrected by gradually applying rated voltage in series with a resistor of approximately 1 k Ω .

(4) If capacitors are dropped, they can be damaged mechanically or electrically. Avoid using dropped capacitors.

(5) Dented or crushed capacitors should not be used.

The seal integrity can be damaged and loss of electrolyte/ shortened life can result.

2.2 Capacitor insertion

- (1) Verify the correct capacitance and rated voltage of the capacitor.
- (2) Verify the correct polarity of the capacitor before insertion.
- (3) Verify the correct terminal dimension and land pattern size before mount to avoid stress on the terminals.
- (4) Excessive mounting pressure can cause high leakage current, short circuit, or disconnection.

2.3 Reflow soldering

- (1) Surface-mount type capacitor are exclusively for reflow soldering.
When reflow solder is used an ambient heat condition system such as the simultaneous use of infrared and hot-air is recommended.
- (2) Observe proper soldering conditions (temperature, time, etc.). Do not exceed the specified limits.
If the peak temperature is high or if the heating time is long, it may cause deterioration of the electrical characteristics and life characteristics.
Recommended soldering condition is a guideline for ensuring the basic characteristics of the components, but not for the stable soldering conditions. Conditions for proper soldering should be set up according to individual onditions.
 - The Temperature on Capacitor top shall be measured by using thermal couple that is fixed firmly by epoxy glue.
- (3) In case of use in 2 times reflow, 2nd reflow must be done when the capacitor's temperature return back to normal level.
- (4) In our recommended reflow condition , the case discoloration and the case swelling might be slightly generated. But please acknowledge that these two phenomena do not influence the reliability of the product.
- (5) The crack on top marking might be occurred by reflow heat stress.
But please acknowledge that it does not influence the reliability of the product.
- (6) VPS (Vapor Phase Soldering) reflow can cause significant characteristics change and/ or mounting failure due to deformation by acute temperature rise.
VPS is acceptable provided that the process does not exceed recommended reflow profile and temperature rise is less than 3 degC/sec.
Please contact Panasonic for detailed conditions.
- (7) The vibration-proof capacitors of size ø6.3 has support terminals extending from the bottom side to the lead edge.
Then, make sure to find appropriate soldering conditions to form fillet on the support terminals if required for appearance inspection. However, even if sufficient solder fillets are not observed, the reliability of vibration-proof will not be lowered because the support terminals on the bottom side enhance the solder joint to PCB.

2.4 Manual soldering

- (1) Observe temperature and time soldering specifications or do not exceed temperature of 350 °C for 3 seconds or less.
- (2) If a soldered capacitor must be removed and reinserted, avoid excessive stress on the capacitor leads.
- (3) Avoid physical contacts between the tip of the soldering iron and capacitors to prevent or capacitor failure.

2.5 Capacitor handling after soldering

- (1) Avoid moving the capacitor after soldering to prevent excessive stress on the lead wires where they enter the seal. The capacitor may break from element portion due to a torque at outer rim, causing a large stress to terminals.
- (2) Do not use the capacitor as a handle when moving the circuit board assembly. The total weight of the board would apply to element portion through terminals, and the capacitor may break.
- (3) Avoid striking the capacitor after assembly to prevent failure due to excessive shock. The capacitor may break due to excessive shock or load above specified range.

2.6 Circuit board cleaning

- (1) Circuit boards can be immersed or ultrasonically cleaned using suitable cleaning solvents for up to 5 minutes and up to 60 °C maximum temperatures. The boards should be thoroughly rinsed and dried. The use of ozone depleting cleaning agents is not recommended for the purpose of protecting our environment.

[Target solvent]

Pine Alpha ST-100S, Aqua Cleaner 210SEP, Clean-thru 750H / 750L / 710M, Sunelec B-12, Sunelec B-12, Cold Cleaner P3-375, Techno Cleaner 219, DK Be-clear CW-5790, Telpene Cleaner EC-7R, Technocare FRW-17 / FRW-1 / FRV-1

- (2) Avoid using the following solvent groups unless specifically allowed in the specification ;
 - (a) Halogenated cleaning solvents : except for solvent resistant capacitor types, halogenated solvents can permeate the seal and cause internal capacitor corrosion and failure.
For solvent resistant capacitors, carefully follow the temperature and time requirements based on the specification. 1,1,1-trichloroethane should never be used on any aluminum electrolytic capacitor.
 - (b) Alkaline solvents : could react and dissolve the aluminum case.
 - (c) Petroleum based solvents : deterioration of the rubber seal could result.
 - (d) Xylene : deterioration of the rubber seal could result.
 - (e) Acetone : removal of the ink markings on the vinyl sleeve could result.
- (3) A thorough drying after cleaning is required to remove residual cleaning solvents that may be trapped between the capacitor and the circuit board. Avoid drying temperatures, which exceed the upper category temperature of the capacitor.
- (4) Monitor the contamination levels of the cleaning solvents during use in terms of electrical conductivity, pH, specific gravity, or water content.
Chlorine levels can rise with contamination and adversely affect the performance of the capacitor.
Control the flux density in the cleaning agent to be less than 2 mass%.
- (5) Depending on the cleaning method, the marking on a capacitor may be erased or blurred.
※ Please consult us if you are not certain about acceptable cleaning solvents or cleaning methods.

2.7 Mounting adhesives and coating agents

When using mounting adhesives or coating agents to control humidity, avoid using materials containing halogenated solvents.

Also, avoid the use of chloroprene based polymers.

Harden on dry adhesive or coating agents well lest the solvent should be left.

After applying adhesives or coatings, dry thoroughly to prevent residual solvents from being trapped between the capacitor and the circuit board.

Leave more than 1/3 of the sealing portion open, and do not cover that portion with any adhesives or coating.

2.8 Fumigation

In exporting electronic appliances with aluminum electrolytic capacitors, in some cases fumigation treatment using such halogen compound as methyl bromide is conducted for wooden boxes.

If such boxes are not dried well, the halogen left in the box is dispersed while transported and enters in the capacitors inside.

This possibly causes electrical corrosion of the capacitors. Therefore, after performing fumigation and drying make sure that no halogen is left.

Don't perform fumigation treatment to the whole electronic appliances packed in a box.

2.9 Flux

If you use a halogen type (Chlorine type, Bromine type, etc.) high-activity flux, please use it after confirmation in advance, as it may have an impact on performance and reliability of this product due to the residue of the flux.

3. Precautions for using capacitors

3.1 Environmental conditions

Capacitors should not be stored or used in the following environments.

- (1) Exposure to temperatures above the upper category or below the lower category temperature of the capacitor.
- (2) Direct contact with water, salt water, or oil.
- (3) High humidity conditions where water could condense on the capacitor.
- (4) Exposure to toxic gases such as hydrogen sulfide, sulfuric acid, nitric acid, chlorine, chlorine compound, bromine, bromine compound or ammonia.
- (5) Exposure to ozone, radiation, or ultraviolet rays.
- (6) Vibration and shock conditions exceeding specified requirements.

Even within the specified requirements, a large vibration acceleration may be applied due to resonance, so be sure to evaluate and confirm with the actual product.

3.2 Electrical precautions

- (1) Avoid touching the terminals of a capacitor as a possible electric shock could result. The exposed aluminum case is not insulated and could also cause electric shock if touched.
- (2) Avoid short circuiting the area between the capacitor terminals with conductive materials including liquids such as acids or alkaline solutions.
- (3) A low-molecular-weight-shiroxane which is included in a silicon material shall causes abnormal electrical characteristics.

4. Emergency procedures

- (1) If the pressure relief of the capacitor operates, immediately turn off the equipment and disconnect from the power source.
This will minimize an additional damage caused by the vaporizing electrolyte.
- (2) Avoid contact with the escaping electrolyte gas, which can exceed 100 °C temperatures.
If electrolyte or gas enters the eye, immediately flush the eye with large amounts of water.
If electrolyte or gas is ingested by mouth, gargle with water.
If electrolyte contacts the skin, wash with soap and water.

5. Long term storage

- (1) Leakage current of a capacitor increases with long storage times. The aluminum oxide film deteriorates as a function of temperature and time.
If used without reconditioning, an abnormally high current will be required to restore the oxide film.
This surge current could cause the circuit or the capacitor to fail.
Expiration date is 42 months from outgoing inspection date.
However, expiration date for series which are not listed below is 12 months from outgoing inspection date.

Series	Expiration date
S (only High temperature reflow)	42 months from outgoing inspection date
HA (only High temperature reflow)	
HB (only High temperature reflow and 5.4 mm height)	
HC, HD, FCA, FC, FKA, FK, FKS, FN, FP, FT, TG, TK, TP, TC, TCU, TQ	

For storage condition, keep room temperature (5 °C to 35 °C) and humidity (45 % to 85 %) where direct sunshine doesn't reach.

(2) Environmental Conditions

Do not store under condition outside the area described in the specification, and also under conditions listed below.

- (a) Exposure to temperatures above the upper category or below the lower category temperature of the capacitor.
- (b) Direct contact with water, salt water, or oil.
- (c) High humidity conditions where water could condense on the capacitor.
- (d) Exposure to toxic gases such as hydrogen sulfide, sulfuric acid, nitric acid, chlorine, Chlorine compound, Bromine, Bromine compound or ammonia.
- (e) Exposure to ozone, radiation, or ultraviolet rays.
- (f) Vibration and shock conditions exceeding specified requirements.

6. Capacitor disposal

When disposing capacitors, use one of the following methods.

- (1) Incinerate after crushing the capacitor or puncturing the can wall (to prevent explosion due to internal pressure rise).
- (2) Dispose as solid waste.

NOTE : Local laws may have specific disposal requirements which must be followed.

The precautions in using aluminum electrolytic capacitors follow the "Safety application guide for the use in fixed aluminum electrolytic capacitors for electronic equipment", RCR-2367D issued by JEITA in October 2017.

Please refer to the above application guide for details.

■ AEC-O200 compliant

The products are tested based on all or part of the test conditions and methods defined in AEC-O200. Please consult with Panasonic for the details of the product specification and specific evaluation test results, etc., and please review and approve Panasonic's product specification before ordering.

Diagram

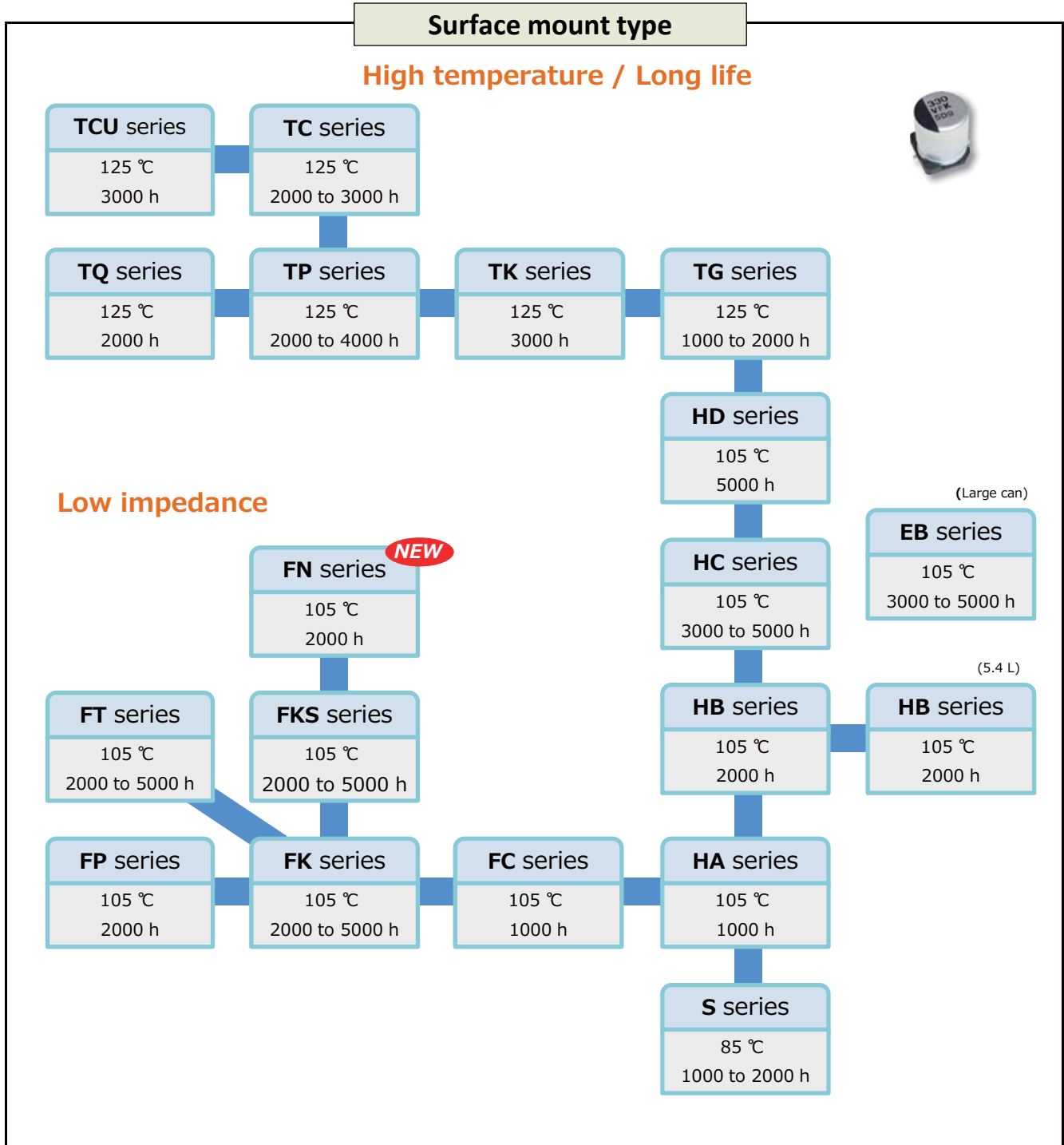

Explanation of part numbers

Part number system

◇ Standard

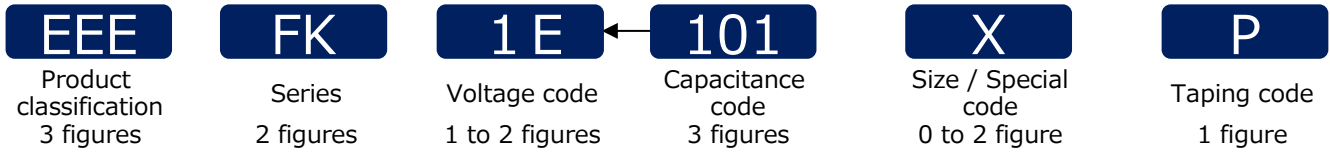

◇ Special 1

EEV

Series	Code	Rated voltage (V)	Code	Cap. (μF)	Code	øD x L (mm)	Code	øD x L (mm)	Code
HA (105 °C 1000 h)	HA	4	0G	1	10	4 to x 5.4 to	-	4.5	R
HB (105 °C 2000 h)	HB	6.3	0J ² (J)	2.2	2R2	4 to 6.3x5.4 (Miniaturization)	W	6.3 to	P
	HB ^{*1}	10	1A ¹ (A)	3.3	3R3	4 to (High temp.reflow)	A	10(x 10.2)	
HC (105 °C 3000 to 5000 h)	HC	16	1C ² (C)	4.7	4R7	4 to 6 (Min.,High temp. reflow)	WA	10(x 13.5)	Q
HD (105 °C 5000 h)	HD	25	1E ² (E)	6.8	6R8	4 to x 5.8 to (Miniaturization)	U	to x 12.5	
FC (105 °C 1000 h)	FC	35	1V ² (V)	10	100	4 to (Min.,High temp. reflow)	UA	16, 18	M
FK (105 °C 2000 to 5000 h)	FK	50	1H ² (H)	18	180	6.3 x 7.7	X	Vibration -proof	V ^{*3}
FKS (105 °C 2000 to 5000 h)	FK	63	1J	22	220	6.3x7.7 (High temp.reflow)	XA		
FN (105 °C 2000 h)	FN	80	1K ² (K)	27	270	FKS series : 6.3x7.7	XS		
FT (105 °C 2000 to 5000 h)	FT	100	2A	33	330	S, HB series : 4 to 6.3x5.4 L	S		
FP (105 °C 2000 h)	FP	160	2C	39	390	EB series : 12.5 to x 16.5 L			
TG (125 °C 1000 to 2000 h)	TG	200	2D	47	470	Bi-poler (Except : HB series)	N		
TK (125 °C 2000 to 3000 h)	TK	250	2E	56	560	FK, FT: 5000h	G		
TP (125 °C 2000 to 3000 h)	TP	350	2V	68	680				
TC (125 °C 2000 to 3000 h)	TC	400	2G	82	820				
TCU (125 °C 3000 h)	TC	450	2W	100	101				
TQ (125 °C 2000 h)	TQ			120	121				
EB (105 °C 3000 to 5000 h)	EB			150	151				
				180	181				
				220	221				
				270	271				
				330	331				
				390	391				
				470	471				
				560	561				
				680	681				
				820	821				
				1000	102				
				1200	122				
				1500	152				
				1800	182				
				2200	222				
				3300	332				
				4700	472				
				6800	682				
				7500	752				

*1: Bi-poler

*2: If part number exceeds 12 figures, voltage code is abbreviated as follows,
0J → J, 1A → A, 1C → C, 1E → E, 1V → V, 1H → H

*3: Vibration-proof product is available upon request.
(øD.8 mm and larger) When requesting vibration-proof product, please put the last

◇ Special 2

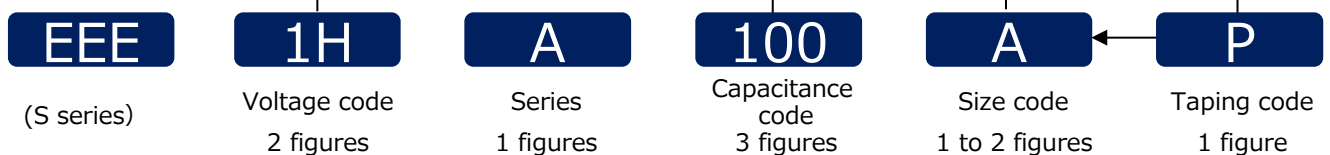

Series	Code
S (85°C 1000 to 2000 h)	A

Recommendable reflow solde

- RoHS compliant

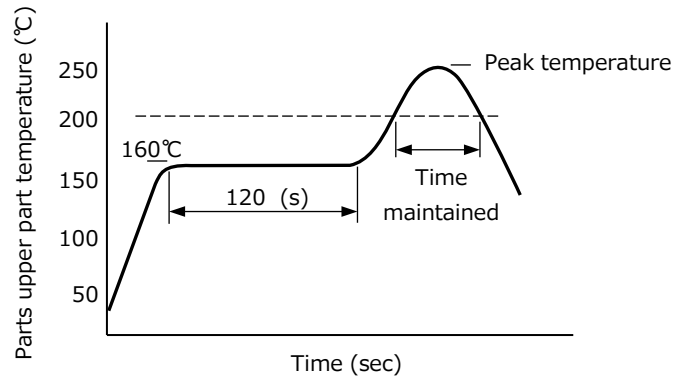

Lead-Free reflow

Reflow No.	(1)	(2)	(3)	(4)
Category	ø4 to ø6.3	ø8 to ø10	ø12.5 to ø18	EB series (ø10 to ø18)
Peak temperature	250 °C	235 °C	230 °C (220 °C)	230 °C
Time in peak temperature	5 s	5 s	5 s (5 s)	5 s
Time maintained	≥200 °C 60 s	≥200 °C 60 s	≥200 °C 20 s (30 s)	≥200 °C 20 s
Time of reflow	1 time	1 time	1 time	1 time

High temperature Lead-Free reflow

Reflow No.	(5)	(6)		(7)		(8)	
Category	ø4 to ø6.3	ø8 to ø10		ø8 to ø10		ø6.3 to ø10 (TK·TP series)	
Peak temperature	260 °C (255 °C)	245 °C	260 °C	250 °C	260 °C	255 °C	260 °C
Time in peak temperature	≥250 °C 5 s (10 s)	≥240 °C 10 s	≥250 °C 5 s	≥240 °C 10 s	≥250 °C 5 s	≥250 °C 30 s	≥250 °C 20 s
Time maintained	≥230 °C 30 s	≥230 °C 30 s	≥230 °C 30 s	≥230 °C 30 s	≥230 °C 30 s	≥230 °C 40 s	≥230 °C 30 s
	≥217 °C 40 s	≥217 °C 40 s	≥217 °C 40 s	≥217 °C 40 s	≥217 °C 40 s	≥217 °C 65 s	≥217 °C 65 s
	≥200 °C 70 s	≥200 °C 70 s	≥200 °C 70 s	≥200 °C 70 s	≥200 °C 70 s	≥200 °C 90 s	≥200 °C 70 s
Time of reflow	2 times	2 times	1 time	2 times	1 time	2 times	2 times

Reflow No.	(9)	(10)	(11)
Category	ø12.5 to ø18 (FK, TK, HD) 6.3 V to 35 V	ø12.5 to ø18 (FK) 50 V to 63 V (TK) 50 V	ø12.5 to ø18 (FK) 80 V to 100 V (TK) 63 V to 100 V
Peak temperature	245 °C	245 °C	245 °C
Time in peak temperature	≥240 °C 30 s	≥240 °C 5 s	≥240 °C 5 s
Time maintained	≥217 °C 90 s	≥217 °C 30 s	≥217 °C 30 s
Time of reflow	2 times	2 times	1 time

- * For reflow, use a thermal condition system such as infrared radiation (IR) or hot blast.
- * Panasonic have several series available for pure Tin terminal and ZVEI reflow based on J-STD-020D (JEDEC). (Please contact sales for details.)

Dimensions (Vibration-proof products)

* The size and shape are different from standard products. Please inquire details of our company.

< Size code : D, D8 >

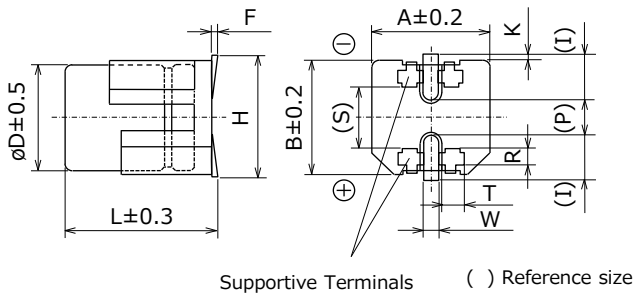

< Size code : E, F, G, H13, J16, K16, K21 >

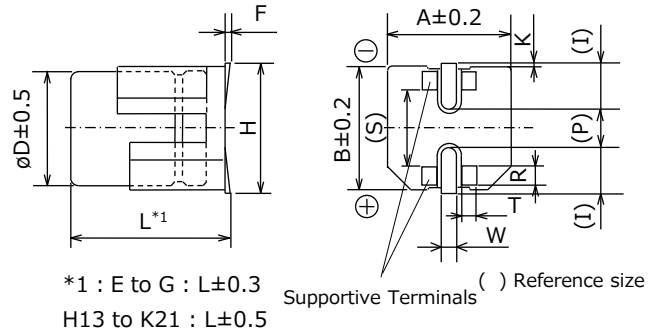

Unit : mm

Size code	ϕD	L	A, B	H max.	F	I	W	P	K	R	S	T
D	6.3	6.1	6.6	7.8	0 to +0.15	2.4	0.65±0.1	2.2	0.35 ^{+0.15} _{-0.20}	1.1±0.2	3.3	1.05±0.2
D8	6.3	8.0	6.6	7.8	0 to +0.15	2.4	0.65±0.1	2.2	0.35 ^{+0.15} _{-0.20}	1.1±0.2	3.3	1.05±0.2
E	8.0	6.5	8.3	9.5	0 to +0.15	3.4	0.7±0.1	2.2	0.35 ^{+0.15} _{-0.20}	0.70±0.2	5.3	1.7±0.2
F	8.0	10.5	8.3	10.0	0 to +0.15	3.4	1.2±0.2	3.1	0.70±0.2	0.70±0.2	5.3	1.3±0.2
G	10.0	10.5	10.3	12.0	0 to +0.15	3.5	1.2±0.2	4.6	0.70±0.2	0.70±0.2	6.9	1.3±0.2
H13	12.5	13.8	13.5	15.0	-0.1 to +0.15	4.7	1.2±0.2	4.4	0.70±0.3	2.2±0.2	7.1	2.4±0.2
J16	16.0	16.8	17.0	19.0	-0.1 to +0.15	5.5	1.4±0.2	6.7	0.70±0.3	3.0±0.2	9.0	1.9±0.2
K16	18.0	16.8	19.0	21.0	-0.1 to +0.15	6.7	1.4±0.2	6.7	0.70±0.3	3.0±0.2	11.0	1.9±0.2
K21	18.0	21.8	19.0	21.0	-0.1 to +0.15	6.7	1.4±0.2	6.7	0.70±0.3	3.0±0.2	11.0	1.9±0.2

Land / Pad pattern

The circuit board land/pad pattern size for chip capacitors is specified in the following table. The land pitch influences installation strength and consider it.

● Standard products

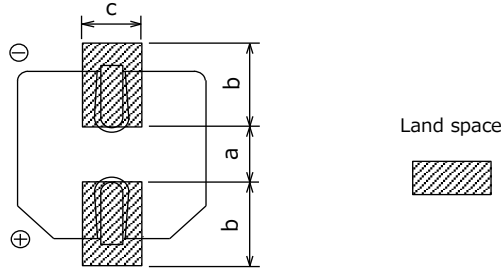

(Table of board land size vs. capacitor size)

Size code	a	b	c
B (ø4)	1.0	2.5	1.6
C (ø5)	1.5	2.8	1.6
D (ø6.3)	1.8	3.2	1.6
D8 (ø6.3x7.7L)	1.8	3.2	1.6
E (ø8x6.2L)	2.2	4.0	1.6
F (ø8x10.2L)	3.1	4.0	2.0
G (ø10x10.2L)	4.6	4.1	2.0
H (ø12.5)	4.0	5.7	2.0
J (ø16)	6.0	6.5	2.5
K (ø18)	6.0	7.5	2.5

Unit : mm

When size "a" is wide, back fillet can be made, decreasing fitting strength.

● Vibration-proof products

< Size code : D, D8 >

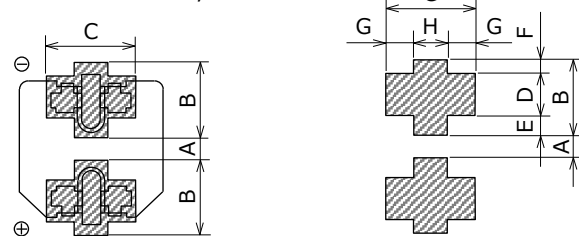

(Table of board land size vs. capacitor size)

Size code	A	B	C	D	E	F	G	H
D (ø6.3xL6.1)	1.2	3.6	3.2	2.0	0.95	0.65	1.0	1.2
D8 (ø6.3xL8.0)	1.2	3.6	3.2	2.0	0.95	0.65	1.0	1.2
E (ø8x6.5L)	1.8	4.2	5.0	1.3	1.5	1.4	1.5	2.0
F (ø8x10.5L)	2.7	4.0	4.7	1.3	1.0	1.7	1.1	2.5
G (ø10)	3.9	4.4	4.7	1.3	1.2	1.9	1.1	2.5
H (ø12.5)	3.9	6.0	6.9	2.8	1.3	1.9	2.2	2.5
J (ø16)	5.8	6.8	6.2	3.6	1.3	1.9	1.7	2.8
K (ø18)	5.8	7.3	6.2	3.6	1.8	1.9	1.7	2.8

Unit : mm

When size "A" is wide, back fillet can be made, decreasing fitting strength.

< Size code : E, F, G, H, J, K >

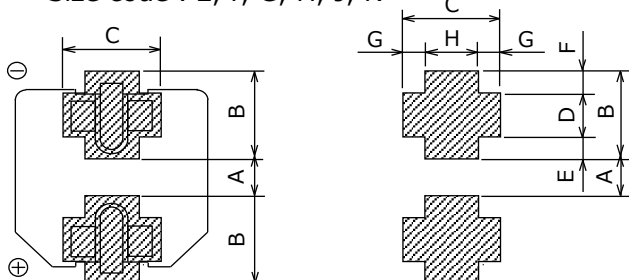

* Take mounting conditions, solderability and fitting strength into consideration when selecting parts for your company's design.

* The vibration-proof capacitors of size ø6.3 has support terminals extending from the bottom side to the lead edge. Then, make sure to find appropriate soldering conditions to form fillet on the support terminals if required for appearance inspection.

Packaging specifications

● Reel dimensions

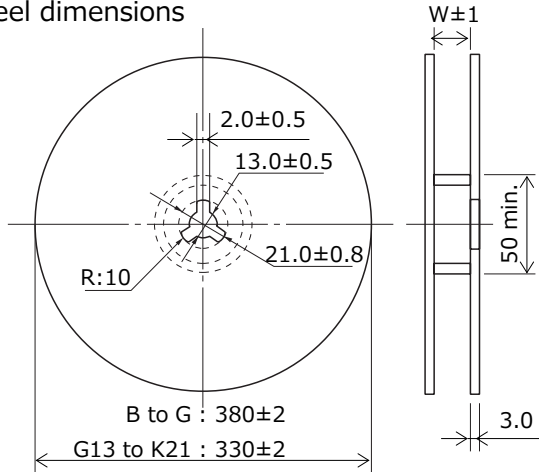

Size code	W	Size code	W
B, C	14.0	G13, G17, H13, H16	34.0
D, E, D8	18.0	J16, J21, K16, K21	46.0
F, G	26.0		

● Dimensions of outer carton box

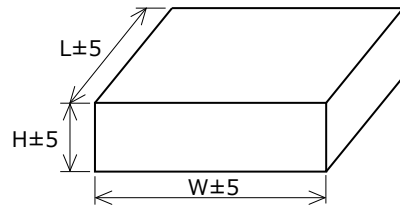

Size code	H	W, L
B, C	220	395
D, D8, E	250	395
F, G	220	395
G13, G17	210	350
H13, H16		
J16, J21	230	350
K16, K21		

● Taping dimensions (size B to G)

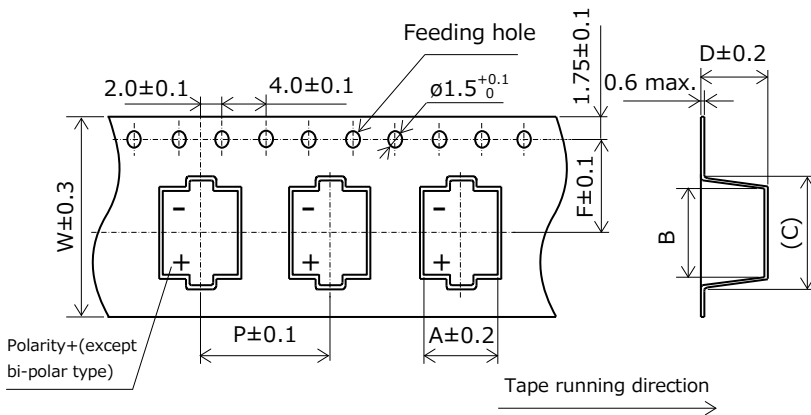

() Reference size

● Min.packing quantity

Size code	Height	Min.packing quantity pcs.
		380 mm reel
B	L=5.4 mm	2000
	L=5.8 mm	2000
C, D	L=5.4 mm	1000
	L=5.8 mm	1000
E	—	1000
D8	—	900
F, G	—	500

Size code	Min.packing quantity pcs.
	330 mm reel
G13	250
G17, H13	200
H16	150
J16, K16	125
J21, K21	75

Ask factory for technical specifications.

Size code	W	A	B	C	P	F	D	
							Height	
							L=5.4 mm	L=5.8 mm
B	12.0	4.7	4.6 ^{+0.2} _{-0.1}	6.5	8.0	5.5	5.8	6.2
C	12.0	5.7	5.7 ^{+0.3} _{-0.2}	8.0	12.0	5.5	5.8	6.4
D	16.0	7.0	7.0 ^{+0.3} _{-0.2}	9.0	12.0	7.5	5.8	6.4
D8	16.0	7.0	7.0 ^{+0.3} _{-0.2}	9.0	12.0	7.5	8.4	
E	16.0	8.7	8.7 ^{+0.3} _{-0.2}	11.4	12.0	7.5	6.8	
F	24.0	8.7	8.7 ^{+0.3} _{-0.2}	12.5	16.0	11.5	11.0	
G	24.0	10.7	10.7 ^{+0.3} _{-0.2}	14.5	16.0	11.5	11.0	

Packaging specifications

- Taping dimensions (size G13 to K21)

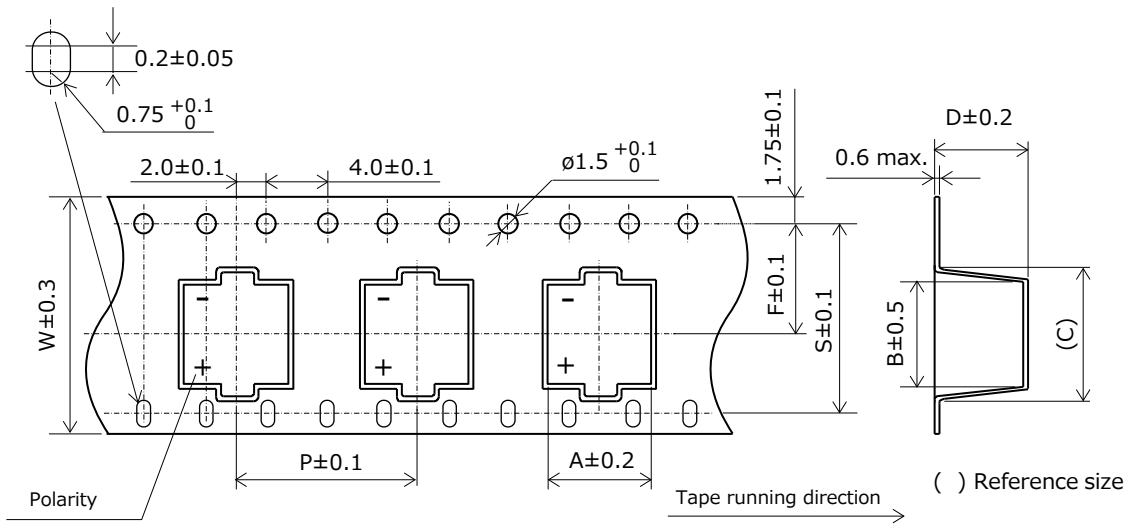

Ask factory for technical specifications.

Unit : mm

Size code	Taping size							
	A	B	C	D	F	P	S	W
G13	10.7	10.7	14.5	14.5	14.2	20.0	28.4	32.0
G17	10.7	10.7	14.5	17.5	14.2	20.0	28.4	32.0
H13	14.0	14.0	18.0	14.5	14.2	24.0	28.4	32.0
H16	14.0	14.0	18.0	17.5	14.2	24.0	28.4	32.0
J16	17.5	17.5	23.0	17.5	20.2	28.0	40.4	44.0
J21	17.5	17.5	23.0	22.5	20.2	28.0	40.4	44.0
K16	19.5	19.5	26.0	17.5	20.2	32.0	40.4	44.0
K21	19.5	19.5	26.0	22.5	20.2	32.0	40.4	44.0

Surface Mount Type

S series **V** type

High temperature Lead-Free reflow (suffix : A*)



Features

- Endurance : 85 °C 2000 h
- Vibration-proof product (30G guaranteed) is available upon request. (ø8 ≤)
- AEC-Q200 compliant
- RoHS compliant

Specifications

Category temp. range	-40 °C to +85 °C							
Rated voltage range	6.3 V to 50 V							
Capacitance range	1 μF to 1500 μF							
Capacitance tolerance	±20 % (120 Hz / +20 °C)							
Leakage current	I ≤ 0.01 CV or 3 (μA) After 2 minutes (Whichever is greater)							
Dissipation factor (tan δ)	Please see the attached characteristics list							
Characteristics at low temperature	Rated voltage (V)	6.3	10	16	25	35	50	(Impedance ratio at 120 Hz)
	Z (-25 °C) / Z (+20 °C)	4	3	2	2	2	2	
	Z (-40 °C) / Z (+20 °C)	8	6	4	4	3	3	
Endurance	After applying rated working voltage for 2000 h (Bi-polar:1000 h for each polarity) at +85 °C ± 2 °C and then being stabilized at +20 °C, capacitors shall meet the following limits.							
	Capacitance change	Within ±20 % of the initial value						
		Size code	Capacitance change					
		D8 (ø6.3)	2000 hours ±25 %					
≤ D (ø6.3) Miniature	1000 hours ±30 %							
Dissipation factor (tan δ)	≤ 200 % of the initial limit							
Leakage current	Within the initial limit							
Shelf life	After storage for 1000 h at +85 °C ± 2 °C with no voltage applied and then being stabilized at +20 °C, capacitors shall meet the limits specified in endurance. (With voltage treatment)							
Resistance to soldering heat	After reflow soldering and then being stabilized at +20 °C, capacitors shall meet the following limits.							
	Capacitance change	Within ±10 % of the initial value						
	Dissipation factor (tan δ)	Within the initial limit						
	Leakage current	Within the initial limit						

Frequency correction factor for ripple current

Frequency (Hz)	50, 60	120	1 k	10 k to
Correction factor	0.70	1.00	1.30	1.70

Marking

Example : 6.3 V 22 μF
Marking color : BLACK

Negative polarity marking (-)

Capacitance (μF)

Series identification

Mark for Lead-Free products (Black dot)

Rated voltage (V)
(6=6.3 V)

Lot number

Dimensions

0.3 max.

øD±0.5

L

H

A±0.2

I

W

P

K

()Reference size

Pressure Relief (ø10 and larger)

Unit : mm

Size code	øD	L	A, B	H	I	W	P	K
B	4.0	5.4 ^{+0.1} _{-0.2}	4.3	5.5 max.	1.8	0.65±0.1	1.0	0.35 ^{+0.15} _{-0.20}
C	5.0	5.4 ^{+0.1} _{-0.2}	5.3	6.5 max.	2.2	0.65±0.1	1.5	0.35 ^{+0.15} _{-0.20}
D	6.3	5.4 ^{+0.1} _{-0.2}	6.6	7.8 max.	2.6	0.65±0.1	1.8	0.35 ^{+0.15} _{-0.20}
D8	6.3	7.7±0.3	6.6	7.8 max.	2.6	0.65±0.1	1.8	0.35 ^{+0.15} _{-0.20}
E	8.0	6.2±0.3	8.3	9.5 max.	3.4	0.65±0.1	2.2	0.35 ^{+0.15} _{-0.20}
F	8.0	10.2±0.3	8.3	10.0 max.	3.4	0.90±0.2	3.1	0.70±0.2
G	10.0	10.2±0.3	10.3	12.0 max.	3.5	0.90±0.2	4.6	0.70±0.2

*The dimensions of the vibration-proof products, please refer to the page of the mounting specification.

Characteristics list

Rated voltage (V)	Capacitance (±20 %) (μF)	Case size (mm)		Size code*1	Specification			Part No.	Reflow	Min. Packaging Q'ty (pcs)
		øD	L		Ripple current*2 (mA rms)	tanδ*3	Endurance (hours)			Taping
6.3	22	4.0	5.4	B	29	0.30	2000	EEE0JA220AR	(5)	2000
	33	4.0	5.4	(B)	22	0.35	1000	EEE0JA330WAR	(5)	2000
	47	5.0	5.4	C	46	0.30	2000	EEE0JA470AR	(5)	1000
	100	5.0	5.4	(C)	47	0.40	1000	EEE0JA101WAR	(5)	1000
		6.3	5.4	D	71	0.30	2000	EEE0JA101AP	(5)	1000
	330	6.3	7.7	D8	188	0.30	2000	EEE0JA331XAP	(5)	900
		8.0	6.2	E	300	0.35	2000	EEE0JA331AP	(7)	1000
	470	8.0	10.2	(F)	380	0.35	1000	EEE0JA471UAP	(7)	500
1000	10.0	10.2	G	700	0.35	2000	EEE0JA102AP	(7)	500	
1500	10.0	10.2	(G)	750	0.50	1000	EEE0JA152UAP	(7)	500	
10	22	4.0	5.4	(B)	28	0.30	1000	EEE1AA220WAR	(5)	2000
	33	4.0	5.4	(B)	29	0.30	1000	EEE1AA330WAR	(5)	2000
		5.0	5.4	C	43	0.22	2000	EEE1AA330AR	(5)	1000
	47	5.0	5.4	(C)	47	0.30	1000	EEE1AA470WAR	(5)	1000
	100	5.0	5.4	(C)	50	0.30	1000	EEE1AA101WAR	(5)	1000
		6.3	5.4	D	70	0.26	2000	EEE1AA101AP	(5)	1000
	220	6.3	7.7	D8	173	0.22	2000	EEE1AA221XAP	(5)	900
		8.0	6.2	E	250	0.26	2000	EEE1AA221AP	(7)	1000
	330	8.0	10.2	F	390	0.26	2000	EEE1AA331AP	(7)	500
	470	8.0	10.2	(F)	390	0.26	1000	EEE1AA471UAP	(7)	500
10.0		10.2	G	400	0.26	2000	EEE1AA471AP	(7)	500	
1000	10.0	10.2	(G)	580	0.35	1000	EEE1AA102UAP	(7)	500	
16	10	4.0	5.4	B	28	0.16	2000	EEE1CA100AR	(5)	2000
	22	4.0	5.4	(B)	28	0.26	1000	EEE1CA220WAR	(5)	2000
		5.0	5.4	C	39	0.16	2000	EEE1CA220AR	(5)	1000
	33	5.0	5.4	(C)	35	0.26	1000	EEE1CA330WAR	(5)	1000
	47	5.0	5.4	(C)	39	0.26	1000	EEE1CA470WAR	(5)	1000
		6.3	5.4	D	70	0.16	2000	EEE1CA470AP	(5)	1000
	100	6.3	5.4	(D)	70	0.26	1000	EEE1CA101WAP	(5)	1000
		8.0	6.2	E	200	0.20	2000	EEE1CA101AP	(7)	1000
	220	6.3	7.7	D8	162	0.20	2000	EEE1CA221XAP	(5)	900
		8.0	10.2	(F)	280	0.20	1000	EEE1CA221UAP	(7)	500
	330	8.0	10.2	(F)	320	0.20	1000	EEE1CA331UAP	(7)	500
		10.0	10.2	G	380	0.20	2000	EEE1CA331AP	(7)	500
	470	8.0	10.2	(F)	350	0.26	1000	EEE1CA471UAP	(7)	500
		10.0	10.2	G	420	0.20	2000	EEE1CA471AP	(7)	500
25	4.7	4.0	5.4	B	22	0.14	2000	EEE1EA4R7AR	(5)	2000
	10	4.0	5.4	(B)	22	0.20	1000	EEE1EA100WAR	(5)	2000
		5.0	5.4	C	28	0.14	2000	EEE1EA100AR	(5)	1000
	22	5.0	5.4	(C)	35	0.20	1000	EEE1EA220WAR	(5)	1000
		6.3	5.4	D	55	0.14	2000	EEE1EA220AP	(5)	1000
	33	5.0	5.4	(C)	42	0.20	1000	EEE1EA330WAR	(5)	1000
		6.3	5.4	D	65	0.14	2000	EEE1EA330AP	(5)	1000
	47	6.3	5.4	(D)	70	0.20	1000	EEE1EA470WAP	(5)	1000
	100	8.0	6.2	(E)	91	0.16	1000	EEE1EA101UAP	(7)	1000
		6.3	7.7	D8	143	0.16	2000	EEE1EA101XAP	(5)	900
		8.0	10.2	F	180	0.16	2000	EEE1EA101AP	(7)	500
	220	8.0	10.2	(F)	230	0.20	1000	EEE1EA221UAP	(7)	500
		10.0	10.2	G	310	0.16	2000	EEE1EA221AP	(7)	500
	330	8.0	10.2	(F)	270	0.20	1000	EEE1EA331UAP	(7)	500
10.0		10.2	G	340	0.16	2000	EEE1EA331AP	(7)	500	
470	10.0	10.2	(G)	380	0.25	1000	EEE1EA471UAP	(7)	500	

*1: Size code() : Miniaturization product

*2: Ripple current (120 Hz / +85 °C)

*3: tanδ (120 Hz / +20 °C)

• Please refer to the page of "Reflow Profile" and "The Taping Dimensions".

• When requesting vibration-proof product, please put the last "V" instead to "P"

Characteristics list

Rated voltage (V)	Capacitance (±20 %) (μF)	Case size (mm)		Size code*1	Specification			Part No.	Reflow	Min. Packaging Q'ty (pcs)
		øD	L		Ripple current*2 (mA rms)	tanδ*3	Endurance (hours)			Taping
35	4.7	4.0	5.4	B	22	0.12	2000	EEE1VA4R7AR	(5)	2000
	10	4.0	5.4	(B)	22	0.16	1000	EEE1VA100WAR	(5)	2000
		5.0	5.4	C	30	0.12	2000	EEE1VA100AR	(5)	1000
	22	5.0	5.4	(C)	36	0.16	1000	EEE1VA220WAR	(5)	1000
		6.3	5.4	D	60	0.12	2000	EEE1VA220AP	(5)	1000
	33	6.3	5.4	(D)	60	0.16	1000	EEE1VA330WAP	(5)	1000
		8.0	6.2	E	130	0.14	2000	EEE1VA330AP	(7)	1000
	47	6.3	5.4	(D)	70	0.16	1000	EEE1VA470WAP	(5)	1000
		8.0	6.2	E	165	0.14	2000	EEE1VA470AP	(7)	1000
	100	6.3	7.7	D8	132	0.14	2000	EEE1VA101XAP	(5)	900
		8.0	10.2	(F)	140	0.14	1000	EEE1VA101UAP	(7)	500
		10.0	10.2	G	210	0.14	2000	EEE1VA101AP	(7)	500
	220	8.0	10.2	(F)	200	0.14	1000	EEE1VA221UAP	(7)	500
		10.0	10.2	G	310	0.14	2000	EEE1VA221AP	(7)	500
330	10.0	10.2	(G)	350	0.30	1000	EEE1VA331UAP	(7)	500	
50	1	4.0	5.4	B	10	0.12	2000	EEE1HA1R0AR	(5)	2000
	2.2	4.0	5.4	B	16	0.12	2000	EEE1HA2R2AR	(5)	2000
	3.3	4.0	5.4	B	16	0.12	2000	EEE1HA3R3AR	(5)	2000
	4.7	4.0	5.4	(B)	18	0.14	1000	EEE1HA4R7WAR	(5)	2000
		5.0	5.4	C	23	0.12	2000	EEE1HA4R7AR	(5)	1000
	10	5.0	5.4	(C)	27	0.14	1000	EEE1HA100WAR	(5)	1000
		6.3	5.4	D	35	0.12	2000	EEE1HA100AP	(5)	1000
	22	6.3	5.4	(D)	40	0.14	1000	EEE1HA220WAP	(5)	1000
		8.0	6.2	E	120	0.12	2000	EEE1HA220AP	(7)	1000
	33	8.0	6.2	(E)	65	0.12	1000	EEE1HA330UAP	(7)	1000
		6.3	7.7	D8	65	0.14	2000	EEE1HA330XAP	(5)	900
		8.0	10.2	F	110	0.12	2000	EEE1HA330AP	(7)	500
	47	6.3	7.7	D8	105	0.14	2000	EEE1HA470XAP	(5)	900
		8.0	10.2	(F)	110	0.12	1000	EEE1HA470UAP	(7)	500
		10.0	10.2	G	130	0.12	2000	EEE1HA470AP	(7)	500
	100	8.0	10.2	(F)	200	0.18	1000	EEE1HA101UAP	(7)	500
10.0		10.2	G	250	0.12	2000	EEE1HA101AP	(7)	500	
220	10.0	10.2	(G)	300	0.18	1000	EEE1HA221UAP	(7)	500	

*1: Size code() : Miniaturization product

*2: Ripple current (120 Hz / +85 °C)

*3: tanδ (120 Hz / +20 °C)

• Please refer to the page of "Reflow Profile" and "The Taping Dimensions".

• When requesting vibration-proof product, please put the last "V" instead to "P"

Surface Mount Type

S series

V type



Features

- Endurance : 85 °C 2000 h
- Vibration-proof product (30G guaranteed) is available upon request. (ø8 ≦)
- AEC-Q200 compliant
- RoHS compliant

Specifications

Category temp. range	-40 °C to +85 °C										
Rated voltage range	4.0 V to 100 V										
Capacitance range	1 µF to 1500 µF										
Capacitance tolerance	±20 % (120 Hz / +20 °C)										
Leakage current	I ≤ 0.01 CV or 3 (µA) (Bi-Polar I ≤ 0.02 CV or 6 (µA)) After 2 minutes (Whichever is greater)										
Dissipation factor (tan δ)	Please see the attached characteristics list										
Characteristics at low temperature	Rated voltage (V)	4.0	6.3	10	16	25	35	50	63	100	(Impedance ratio at 120 Hz)
	Z (-25 °C) / Z (+20 °C)	7	4	3	2	2	2	2	3	3	
	Z (-40 °C) / Z (+20 °C)	15	8	6	4	4	3	3	4	4	
Endurance	After applying rated working voltage for 2000 h (Bi-polar:1000 h for each polarity) at +85 °C ± 2 °C and then being stabilized at +20 °C, capacitors shall meet the following limits.										
	Capacitance change	Within ±20 % of the initial value									
		Size code	Rated voltage		Capacitance change						
		B(ø4) to D, D8(ø6.3)	4 V		1000 hours ±30 %						
≤ D(ø6.3) Miniature	6.3 V		1000 hours ±20 %								
≥ 10 V	≥ 10 V										
Dissipation factor (tan δ)	≤ 200 % of the initial limit										
Leakage current	Within the initial limit										
Shelf life	After storage for 1000 h at +85 °C ± 2 °C with no voltage applied and then being stabilized at +20 °C, capacitors shall meet the limits specified in endurance. (With voltage treatment)										
Resistance to soldering heat	After reflow soldering and then being stabilized at +20 °C, capacitors shall meet the following limits.										
	Capacitance change	Within ±10 % of the initial value									
	Dissipation factor (tan δ)	Within the initial limit									
	Leakage current	Within the initial limit									

Frequency correction factor for ripple current

Frequency (Hz)	50, 60	120	1 k	10 k to
Correction factor	0.70	1.00	1.30	1.70

Marking

Example : 4 V 33 µF
Marking color : BLACK

Negative polarity marking (-)
(No marking for the bi-polar)

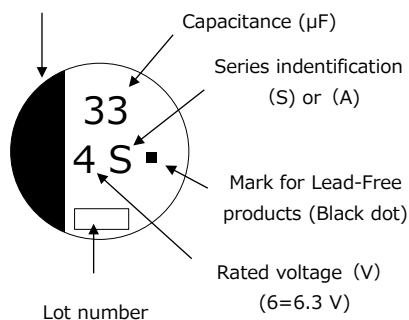

Dimensions

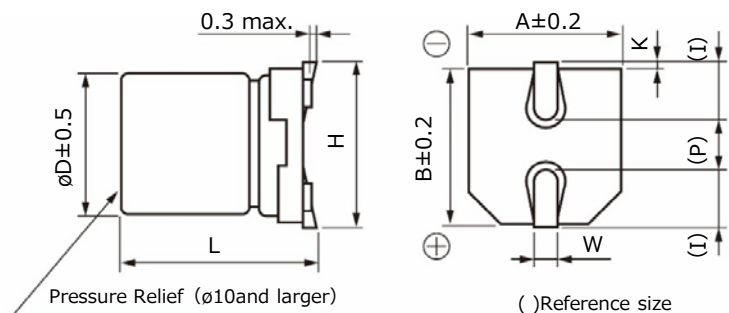

Size code	øD	L	A, B	H	I	W	P	K
B	4.0	5.4	^{+0.1} _{-0.2}	4.3	5.5 max.	1.8	0.65±0.1	1.0 0.35 ^{+0.15} _{-0.20}
C	5.0	5.4	^{+0.1} _{-0.2}	5.3	6.5 max.	2.2	0.65±0.1	1.5 0.35 ^{+0.15} _{-0.20}
D	6.3	5.4	^{+0.1} _{-0.2}	6.6	7.8 max.	2.6	0.65±0.1	1.8 0.35 ^{+0.15} _{-0.20}
D8	6.3	7.7±0.3	6.6	7.8 max.	2.6	0.65±0.1	1.8 0.35 ^{+0.15} _{-0.20}	
E	8.0	6.2±0.3	8.3	9.5 max.	3.4	0.65±0.1	2.2 0.35 ^{+0.15} _{-0.20}	
F	8.0	10.2±0.3	8.3	10.0 max.	3.4	0.90±0.2	3.1 0.70±0.2	
G	10.0	10.2±0.3	10.3	12.0 max.	3.5	0.90±0.2	4.6 0.70±0.2	

Unit : mm

Characteristics list

Rated voltage (V)	Capacitance (±20 %) (μF)	Case size (mm)		Size code*1	Specification			Part No.	Reflow	Min. Packaging Q'ty (pcs)
		øD	L		Ripple current*2 (mA rms)	tanδ*3	Endurance (hours)			Taping
4	33	4.0	5.4	B	26	0.35	1000	EEE0GA330SR	(1)	2000
	47	4.0	5.4	B	34	0.35	1000	EEE0GA470SR	(1)	2000
	100	5.0	5.4	C	61	0.35	1000	EEE0GA101SR	(1)	1000
	220	6.3	5.4	D	82	0.35	1000	EEE0GA221SP	(1)	1000
	330	6.3	5.4	(D)	80	0.50	1000	EEE0GA331WP	(1)	1000
	470	6.3	7.7	D8	200	0.35	1000	EEE0GA471XP	(1)	900
6.3	22	4.0	5.4	B	29	0.26	2000	EEE0JA220SR	(1)	2000
	33	4.0	5.4	(B)	22	0.35	1000	EEE0JA330WR	(1)	2000
	47	4.0	5.4	(B)	36	0.35	1000	EEE0JA470WR	(1)	2000
		5.0	5.4	C	46	0.26	2000	EEE0JA470SR	(1)	1000
	100	5.0	5.4	(C)	47	0.35	1000	EEE0JA101WR	(1)	1000
		6.3	5.4	D	71	0.26	2000	EEE0JA101SP	(1)	1000
	220	6.3	5.4	(D)	74	0.35	1000	EEE0JA221WP	(1)	1000
	330	6.3	7.7	D8	188	0.26	2000	EEE0JA331XP	(1)	900
		8.0	6.2	E	300	0.35	2000	EEE0JA331P	(2)	1000
	470	8.0	10.2	F	380	0.35	2000	EEE0JA471P	(2)	500
1000	8.0	10.2	(F)	500	0.35	2000	EEE0JA102UP	(2)	500	
	10.0	10.2	G	700	0.35	2000	EEE0JA102P	(2)	500	
1500	10.0	10.2	G	750	0.35	2000	EEE0JA152P	(2)	500	
10	22	4.0	5.4	(B)	28	0.30	1000	EEE1AA220WR	(1)	2000
	33	4.0	5.4	(B)	29	0.30	1000	EEE1AA330WR	(1)	2000
		5.0	5.4	C	43	0.20	2000	EEE1AA330SR	(1)	1000
	47	5.0	5.4	(C)	43	0.30	1000	EEE1AA470WR	(1)	1000
	100	5.0	5.4	(C)	50	0.30	1000	EEE1AA101WR	(1)	1000
		6.3	5.4	D	70	0.26	2000	EEE1AA101SP	(1)	1000
	220	6.3	7.7	D8	173	0.20	2000	EEE1AA221XP	(1)	900
		8.0	6.2	E	250	0.26	2000	EEE1AA221P	(2)	1000
	330	8.0	10.2	F	390	0.26	2000	EEE1AA331P	(2)	500
	470	8.0	10.2	(F)	390	0.26	2000	EEE1AA471UP	(2)	500
10.0		10.2	G	400	0.26	2000	EEE1AA471P	(2)	500	
1000	10.0	10.2	G	580	0.26	2000	EEE1AA102P	(2)	500	
16	10	4.0	5.4	B	28	0.16	2000	EEE1CA100SR	(1)	2000
	22	4.0	5.4	(B)	28	0.26	1000	EEE1CA220WR	(1)	2000
		5.0	5.4	C	39	0.16	2000	EEE1CA220SR	(1)	1000
	33	5.0	5.4	(C)	35	0.26	1000	EEE1CA330WR	(1)	1000
	47	5.0	5.4	(C)	39	0.26	1000	EEE1CA470WR	(1)	1000
		6.3	5.4	D	70	0.16	2000	EEE1CA470SP	(1)	1000
	100	6.3	5.4	(D)	70	0.26	1000	EEE1CA101WP	(1)	1000
		8.0	6.2	E	200	0.20	2000	EEE1CA101P	(2)	1000
	220	6.3	7.7	D8	162	0.16	2000	EEE1CA221XP	(1)	900
		8.0	6.2	E	200	0.20	2000	EEE1CA221UP	(2)	1000
		8.0	10.2	F	280	0.20	2000	EEE1CA221P	(2)	500
	330	8.0	10.2	(F)	320	0.20	2000	EEE1CA331UP	(2)	500
		10.0	10.2	G	380	0.20	2000	EEE1CA331P	(2)	500
	470	8.0	10.2	(F)	350	0.20	2000	EEE1CA471UP	(2)	500
		10.0	10.2	G	420	0.20	2000	EEE1CA471P	(2)	500

*1: Size code() : Miniaturization product

*2: Ripple current (120 Hz / +85 °C)

*3: tanδ (120 Hz / +20 °C)

• Please refer to the page of "Reflow Profile" and "The Taping Dimensions".

• When requesting vibration-proof product, please put the last "V" instead to "P"

Characteristics list

Rated voltage (V)	Capacitance (±20 %) (μF)	Case size (mm)		Size code*1	Specification			Part No.	Reflow	Min. Packaging Q'ty (pcs)
		øD	L		Ripple current*2 (mA rms)	tanδ*3	Endurance (hours)			Taping
25	4.7	4.0	5.4	B	22	0.14	2000	EEE1EA4R7SR	(1)	2000
	10	4.0	5.4	(B)	22	0.20	1000	EEE1EA100WR	(1)	2000
		5.0	5.4	C	28	0.14	2000	EEE1EA100SR	(1)	1000
	22	5.0	5.4	(C)	35	0.20	1000	EEE1EA220WR	(1)	1000
		6.3	5.4	D	55	0.14	2000	EEE1EA220SP	(1)	1000
	33	5.0	5.4	(C)	42	0.20	1000	EEE1EA330WR	(1)	1000
		6.3	5.4	D	65	0.14	2000	EEE1EA330SP	(1)	1000
	47	6.3	5.4	(D)	70	0.20	1000	EEE1EA470WP	(1)	1000
	100	6.3	7.7	D8	143	0.14	2000	EEE1EA101XP	(1)	900
		8.0	6.2	(E)	91	0.16	2000	EEE1EA101UP	(2)	1000
		8.0	10.2	F	180	0.16	2000	EEE1EA101P	(2)	500
	220	8.0	10.2	(F)	230	0.16	2000	EEE1EA221UP	(2)	500
		10.0	10.2	G	310	0.16	2000	EEE1EA221P	(2)	500
	330	8.0	10.2	(F)	270	0.16	2000	EEE1EA331UP	(2)	500
10.0		10.2	G	340	0.16	2000	EEE1EA331P	(2)	500	
470	10.0	10.2	G	380	0.16	2000	EEE1EA471P	(2)	500	
35	4.7	4.0	5.4	B	22	0.12	2000	EEE1VA4R7SR	(1)	2000
	10	4.0	5.4	(B)	22	0.16	1000	EEE1VA100WR	(1)	2000
		5.0	5.4	C	30	0.12	2000	EEE1VA100SR	(1)	1000
	22	5.0	5.4	(C)	36	0.16	1000	EEE1VA220WR	(1)	1000
		6.3	5.4	D	60	0.12	2000	EEE1VA220SP	(1)	1000
	33	6.3	5.4	(D)	60	0.16	1000	EEE1VA330WP	(1)	1000
		8.0	6.2	E	130	0.14	2000	EEE1VA330P	(2)	1000
	47	6.3	5.4	(D)	70	0.16	1000	EEE1VA470WP	(1)	1000
		8.0	6.2	E	165	0.14	2000	EEE1VA470P	(2)	1000
	100	6.3	7.7	D8	132	0.12	2000	EEE1VA101XP	(1)	900
		8.0	10.2	(F)	140	0.14	2000	EEE1VA101UP	(2)	500
		10.0	10.2	G	210	0.14	2000	EEE1VA101P	(2)	500
	220	8.0	10.2	(F)	200	0.14	2000	EEE1VA221UP	(2)	500
		10.0	10.2	G	310	0.14	2000	EEE1VA221P	(2)	500
330	10.0	10.2	G	350	0.14	2000	EEE1VA331P	(2)	500	

*1: Size code() : Miniaturization product

*2: Ripple current (120 Hz / +85 °C)

*3: tanδ (120 Hz / +20 °C)

• Please refer to the page of "Reflow Profile" and "The Taping Dimensions".

• When requesting vibration-proof product, please put the last "V" instead to "P"

Characteristics list

Rated voltage (V)	Capacitance (±20 %) (μF)	Case size (mm)		Size code*1	Specification			Part No.	Reflow	Min. Packaging Q'ty (pcs)
		øD	L		Ripple current*2 (mA rms)	tanδ*3	Endurance (hours)			Taping
50	1	4.0	5.4	B	10	0.12	2000	EEE1HA010SR	(1)	2000
	2.2	4.0	5.4	B	16	0.12	2000	EEE1HA2R2SR	(1)	2000
	3.3	4.0	5.4	B	16	0.12	2000	EEE1HA3R3SR	(1)	2000
	4.7	4.0	5.4	(B)	18	0.14	1000	EEE1HA4R7WR	(1)	2000
		5.0	5.4	C	23	0.12	2000	EEE1HA4R7SR	(1)	1000
	10	5.0	5.4	(C)	27	0.14	1000	EEE1HA100WR	(1)	1000
		6.3	5.4	D	35	0.12	2000	EEE1HA100SP	(1)	1000
	22	6.3	5.4	(D)	40	0.14	1000	EEE1HA220WP	(1)	1000
		8.0	6.2	E	120	0.12	2000	EEE1HA220P	(2)	1000
	33	6.3	7.7	D8	85	0.12	2000	EEE1HA330XP	(1)	900
		8.0	6.2	(E)	65	0.12	2000	EEE1HA330UP	(2)	1000
		8.0	10.2	F	110	0.12	2000	EEE1HA330P	(2)	500
	47	6.3	7.7	D8	105	0.12	2000	EEE1HA470XP	(1)	900
		8.0	10.2	(F)	110	0.12	2000	EEE1HA470UP	(2)	500
		10.0	10.2	G	130	0.12	2000	EEE1HA470P	(2)	500
100	8.0	10.2	(F)	200	0.12	2000	EEE1HA101UP	(2)	500	
	10.0	10.2	G	250	0.12	2000	EEE1HA101P	(2)	500	
220	10.0	10.2	G	300	0.12	2000	EEE1HA221P	(2)	500	
63	22	8.0	6.2	(E)	40	0.18	2000	EEE1JA220UP	(2)	1000
		8.0	10.2	F	40	0.18	2000	EEE1JA220P	(2)	500
	33	8.0	10.2	F	45	0.18	2000	EEE1JA330P	(2)	500
	47	8.0	10.2	(F)	45	0.18	2000	EEE1JA470UP	(2)	500
		10.0	10.2	G	45	0.18	2000	EEE1JA470P	(2)	500
	100	10.0	10.2	G	60	0.18	2000	EEE1JA101P	(2)	500
100	4.7	8.0	6.2	(E)	50	0.18	2000	EEE2AA4R7UP	(2)	1000
	10	8.0	6.2	(E)	50	0.18	2000	EEE2AA100UP	(2)	1000
		8.0	10.2	F	85	0.18	2000	EEE2AA100P	(2)	500
	22	8.0	10.2	(F)	55	0.18	2000	EEE2AA220UP	(2)	500
		10.0	10.2	G	85	0.18	2000	EEE2AA220P	(2)	500
	33	10.0	10.2	G	90	0.18	2000	EEE2AA330P	(2)	500

*1: Size code() : Miniaturization product

*2: Ripple current (120 Hz / +85 °C)

*3: tanδ (120 Hz / +20 °C)

• Please refer to the page of "Reflow Profile" and "The Taping Dimensions".

• When requesting vibration-proof product, please put the last "V" instead to "P"

Characteristics list (Bi-polar)

Endurance : 85 °C 2000 h

Rated voltage (V)	Capacitance (±20 %) (μF)	Case size (mm)		Size code	Specification		Part No.	Reflow	Min. Packaging Q'ty (pcs)
		øD	L		Ripple current* ¹ (mA rms)	tan δ* ²			Taping
6.3	22	5.0	5.4	C	29	0.52	EEE0JA220NR	(1)	1000
	47	6.3	5.4	D	46	0.52	EEE0JA470NP	(1)	1000
10	10	4.0	5.4	B	25	0.40	EEE1AA100NR	(1)	2000
	33	6.3	5.4	D	43	0.40	EEE1AA330NP	(1)	1000
16	4.7	4.0	5.4	B	20	0.32	EEE1CA4R7NR	(1)	2000
	10	5.0	5.4	C	25	0.32	EEE1CA100NR	(1)	1000
	22	6.3	5.4	D	39	0.32	EEE1CA220NP	(1)	1000
25	3.3	4.0	5.4	B	12	0.28	EEE1EA3R3NR	(1)	2000
	4.7	5.0	5.4	C	21	0.28	EEE1EA4R7NR	(1)	1000
	10	6.3	5.4	D	28	0.28	EEE1EA100NP	(1)	1000
35	2.2	4.0	5.4	B	12	0.24	EEE1VA2R2NR	(1)	2000
	4.7	5.0	5.4	C	22	0.24	EEE1VA4R7NR	(1)	1000
	10	6.3	5.4	D	30	0.24	EEE1VA100NP	(1)	1000
50	1	4.0	5.4	B	10	0.24	EEE1HA010NR	(1)	2000
	2.2	5.0	5.4	C	16	0.24	EEE1HA2R2NR	(1)	1000
	3.3	5.0	5.4	C	21	0.24	EEENZ1H3R3R	(1)	1000
	4.7	6.3	5.4	D	31	0.24	EEE1HA4R7NP	(1)	1000

*1: Ripple current (120 Hz / +85 °C)

*2: tanδ (120 Hz / +20 °C)

- Please refer to the page of "Reflow Profile" and "The Taping Dimensions".
- When requesting vibration-proof product, please put the last "V" instead to "P"

Surface Mount Type

HA series **V** type

High temperature Lead-Free reflow (suffix : A*)

High-temperature assurance

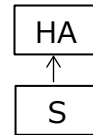

Features

- Endurance : 105 °C 1000 h
- Vibration-proof product (30G guaranteed) is available upon request ($\phi 8 \leq$)
- AEC-Q200 compliant
- RoHS compliant

Specifications

Category temp. range	-40 °C to +105 °C							
Rated voltage range	6.3 V to 50 V							
Capacitance range	1 μ F to 1500 μ F							
Capacitance tolerance	± 20 % (120 Hz / +20°C)							
Leakage current	$I \leq 0.01$ CV or 3 (μ A) After 2 minutes (Whichever is greater)							
Dissipation factor (tan δ)	Please see the attached characteristics list							
Characteristics at low temperature	Rated voltage (V)	6.3	10	16	25	35	50	(Impedance ratio at 120 Hz)
	Z (-25 °C) / Z (+20 °C)	4	3	2	2	2	2	
	Z (-40 °C) / Z (+20 °C)	8	6	4	4	3	3	
Endurance	After applying rated working voltage for 1000 hours at +105 °C ± 2 °C and then being stabilized at +20 °C, capacitors shall meet the following limits.							
	Capacitance change	Within ± 30 % of the initial value						
	Dissipation factor (tan δ)	≤ 200 % of the initial limit						
	DC leakage current	Within the initial limit						
Shelf life	After storage for 1000 hours at +105 °C ± 2 °C with no voltage applied and then being stabilized at +20 °C, capacitors shall meet the limits specified in endurance. (With voltage treatment)							
	After reflow soldering and then being stabilized at +20 °C, capacitors shall meet the following limits.							
Resistance to soldering heat	After reflow soldering and then being stabilized at +20 °C, capacitors shall meet the following limits.							
	Capacitance change	Within ± 10 % of the initial value						
	Dissipation factor (tan δ)	Within the initial limit						
	DC leakage current	Within the initial limit						

Frequency correction factor for ripple current

Frequency (Hz)	50, 60	120	1 k	10 k to
Correction factor	0.70	1.00	1.30	1.70

Marking

Example : 6.3 V 22 μ F
Marking color : BLACK

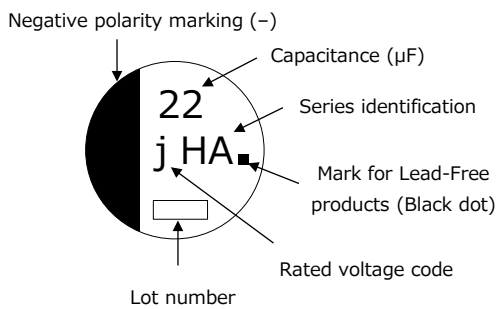

R.voltage code		Unit : V	
j	6.3	E	25
A	10	V	35
C	16	H	50

Dimensions

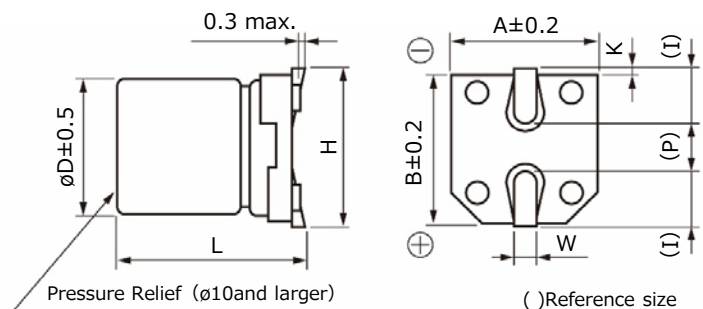

Size code	ϕD	L	A, B	H	I	W	P	K
B	4.0	5.4 $^{+0.1}_{-0.2}$	4.3	5.5 max.	1.8	0.65 ± 0.1	1.0	0.35 $^{+0.15}_{-0.20}$
C	5.0	5.4 $^{+0.1}_{-0.2}$	5.3	6.5 max.	2.2	0.65 ± 0.1	1.5	0.35 $^{+0.15}_{-0.20}$
D	6.3	5.4 $^{+0.1}_{-0.2}$	6.6	7.8 max.	2.6	0.65 ± 0.1	1.8	0.35 $^{+0.15}_{-0.20}$
D8	6.3	7.7 ± 0.3	6.6	7.8 max.	2.6	0.65 ± 0.1	1.8	0.35 $^{+0.15}_{-0.20}$
E	8.0	6.2 ± 0.3	8.3	9.5 max.	3.4	0.65 ± 0.1	2.2	0.35 $^{+0.15}_{-0.20}$
F	8.0	10.2 ± 0.3	8.3	10.0 max.	3.4	0.90 ± 0.2	3.1	0.70 ± 0.2
G	10.0	10.2 ± 0.3	10.3	12.0 max.	3.5	0.90 ± 0.2	4.6	0.70 ± 0.2

*The dimensions of the vibration-proof products, please refer to the page of the mounting specification.

Characteristics list

Endurance : 105 °C 1000 h

Rated voltage (V)	Capacitance (±20 %) (μF)	Case size (mm)		Size code*1	Specification		Part No.	Reflow	Min. Packaging Q'ty (pcs)
		øD	L		Ripple current*2 (mA rms)	tan δ*3			Taping
6.3	22	4.0	5.4	B	29	0.30	EEEHA0J220AR	(5)	2000
	33	4.0	5.4	(B)	29	0.35	EEEHAJ330WAR	(5)	2000
	47	5.0	5.4	C	46	0.30	EEEHA0J470AR	(5)	1000
	100	5.0	5.4	(C)	47	0.40	EEEHAJ101WAR	(5)	1000
		6.3	5.4	D	71	0.30	EEEHA0J101AP	(5)	1000
	330	6.3	7.7	D8	105	0.30	EEEHAJ331XAP	(5)	900
		8.0	6.2	(E)	180	0.35	EEEHAJ331UAP	(7)	1000
		8.0	10.2	F	230	0.35	EEEHA0J331AP	(7)	500
	470	8.0	10.2	(F)	300	0.35	EEEHAJ471UAP	(7)	500
1000	10.0	10.2	G	400	0.35	EEEHA0J102AP	(7)	500	
1500	10.0	10.2	(G)	480	0.50	EEEHAJ152UAP	(7)	500	
10	22	4.0	5.4	(B)	28	0.30	EEEHAA220WAR	(5)	2000
	33	4.0	5.4	(B)	29	0.30	EEEHAA330WAR	(5)	2000
		5.0	5.4	C	43	0.22	EEEHA1A330AR	(5)	1000
	47	5.0	5.4	(C)	43	0.30	EEEHAA470WAR	(5)	1000
	100	6.3	5.4	(D)	71	0.30	EEEHAA101WAP	(5)	1000
		8.0	6.2	E	110	0.26	EEEHA1A101AP	(7)	1000
	220	6.3	7.7	D8	105	0.22	EEEHAA221XAP	(5)	900
		8.0	10.2	F	160	0.26	EEEHA1A221AP	(7)	500
	470	8.0	10.2	(F)	200	0.26	EEEHAA471UAP	(7)	500
10.0		10.2	G	270	0.26	EEEHA1A471AP	(7)	500	
1000	10.0	10.2	(G)	400	0.35	EEEHAA102UAP	(7)	500	
16	10	4.0	5.4	B	28	0.16	EEEHA1C100AR	(5)	2000
	22	4.0	5.4	(B)	28	0.26	EEEHAC220WAR	(5)	2000
		5.0	5.4	C	39	0.16	EEEHA1C220AR	(5)	1000
	33	5.0	5.4	(C)	35	0.26	EEEHAC330WAR	(5)	1000
	47	5.0	5.4	(C)	39	0.26	EEEHAC470WAR	(5)	1000
		6.3	5.4	D	70	0.16	EEEHA1C470AP	(5)	1000
	100	6.3	5.4	(D)	70	0.26	EEEHAC101WAP	(5)	1000
	220	6.3	7.7	D8	105	0.20	EEEHAC221XAP	(5)	900
		8.0	10.2	(F)	150	0.20	EEEHAC221UAP	(7)	500
		10.0	10.2	G	210	0.20	EEEHA1C221AP	(7)	500
	330	8.0	10.2	(F)	170	0.20	EEEHAC331UAP	(7)	500
		10.0	10.2	G	230	0.20	EEEHA1C331AP	(7)	500
	470	8.0	10.2	(F)	340	0.26	EEEHAC471UAP	(7)	500
		10.0	10.2	G	340	0.20	EEEHA1C471AP	(7)	500
680	10.0	10.2	(G)	380	0.26	EEEHAC681UAP	(7)	500	

*1: Size code() : Miniaturization product

*2: Ripple current (120 Hz / +105 °C)

*3: tanδ (120 Hz / +20 °C)

- If Part number exceeds 12 digits, voltage code is abbreviated as follows; 0J → J, 1A → A, 1C → C, 1E → E, 1V → V, 1H → H
- Please refer to the page of "Reflow Profile" and "The Taping Dimensions".
- When requesting vibration-proof product, please put the last "V" instead to "P"

Characteristics list

Endurance : 105 °C 1000 h

Rated voltage (V)	Capacitance (±20 %) (µF)	Case size (mm)		Size code *1	Specification		Part No.	Reflow	Min. Packaging Qty (pcs)
		øD	L		Ripple current*2 (mA rms)	tan δ*3			Taping
25	4.7	4.0	5.4	B	22	0.14	EEEHA1E4R7AR	(5)	2000
	10	4.0	5.4	(B)	22	0.20	EEEHAE100WAR	(5)	2000
		5.0	5.4	C	28	0.14	EEEHA1E100AR	(5)	1000
	22	5.0	5.4	(C)	35	0.20	EEEHAE220WAR	(5)	1000
		6.3	5.4	D	55	0.14	EEEHA1E220AP	(5)	1000
	33	5.0	5.4	(C)	45	0.20	EEEHAE330WAR	(5)	1000
		6.3	5.4	D	65	0.14	EEEHA1E330AP	(5)	1000
	47	6.3	5.4	(D)	70	0.20	EEEHAE470WAP	(5)	1000
		8.0	6.2	E	91	0.16	EEEHA1E470AP	(7)	1000
	100	8.0	6.2	(E)	91	0.16	EEEHAE101UAP	(7)	1000
		6.3	7.7	D8	91	0.16	EEEHAE101XAP	(5)	900
	220	8.0	10.2	F	130	0.16	EEEHA1E101AP	(7)	500
		10.0	10.2	G	160	0.20	EEEHAE221UAP	(7)	500
	330	8.0	10.2	(F)	180	0.20	EEEHAE331UAP	(7)	500
10.0		10.2	G	340	0.16	EEEHA1E331AP	(7)	500	
470	10.0	10.2	(G)	360	0.25	EEEHAE471UAP	(7)	500	
35	4.7	4.0	5.4	B	22	0.12	EEEHA1V4R7AR	(5)	2000
	10	4.0	5.4	(B)	22	0.16	EEEHAV100WAR	(5)	2000
		5.0	5.4	C	30	0.12	EEEHA1V100AR	(5)	1000
	22	5.0	5.4	(C)	35	0.16	EEEHAV220WAR	(5)	1000
		6.3	5.4	D	60	0.12	EEEHA1V220AP	(5)	1000
	33	6.3	5.4	(D)	42	0.16	EEEHAV330WAP	(5)	1000
		8.0	6.2	E	84	0.14	EEEHA1V330AP	(7)	1000
	47	8.0	6.2	(E)	84	0.14	EEEHAV470UAP	(7)	1000
		8.0	10.2	F	98	0.14	EEEHA1V470AP	(7)	500
	100	6.3	7.7	D8	84	0.14	EEEHAV101XAP	(5)	900
		8.0	10.2	(F)	120	0.14	EEEHAV101UAP	(7)	500
	220	10.0	10.2	G	160	0.14	EEEHA1V101AP	(7)	500
		8.0	10.2	(F)	170	0.14	EEEHAV221UAP	(7)	500
	330	10.0	10.2	G	210	0.14	EEEHA1V221AP	(7)	500
10.0		10.2	(G)	250	0.30	EEEHAV331UAP	(7)	500	
50	1	4.0	5.4	B	10	0.12	EEEHA1H1R0AR	(5)	2000
	2.2	4.0	5.4	B	16	0.12	EEEHA1H2R2AR	(5)	2000
	3.3	4.0	5.4	B	16	0.12	EEEHA1H3R3AR	(5)	2000
	4.7	5.0	5.4	C	23	0.12	EEEHA1H4R7AR	(5)	1000
	10	6.3	5.4	D	35	0.12	EEEHA1H100AP	(5)	1000
	22	8.0	6.2	E	70	0.12	EEEHA1H220AP	(7)	1000
		6.3	7.7	D8	70	0.14	EEEHAH330XAP	(5)	900
	33	8.0	6.2	(E)	70	0.12	EEEHAH330UAP	(7)	1000
		8.0	10.2	F	91	0.12	EEEHA1H330AP	(7)	500
	47	6.3	7.7	D8	63	0.14	EEEHAH470XAP	(5)	900
		8.0	10.2	(F)	95	0.12	EEEHAH470UAP	(7)	500
	100	10.0	10.2	G	100	0.12	EEEHA1H470AP	(7)	500
		8.0	10.2	(F)	110	0.18	EEEHAH101UAP	(7)	500
	220	10.0	10.2	G	120	0.12	EEEHA1H101AP	(7)	500
10.0		10.2	(G)	150	0.18	EEEHAH221UAP	(7)	500	

*1: Size code () : Miniaturization product

*2: Ripple current (120 Hz / +105 °C)

*3: tanδ (120 Hz / +20 °C)

- If Part number exceeds 12 digits, voltage code is abbreviated as follows; 0J → J, 1A → A, 1C → C, 1E → E, 1V → V, 1H → H
- Please refer to the page of "Reflow Profile" and "The Taping Dimensions".
- When requesting vibration-proof product, please put the last "V" instead to "P"

Surface Mount Type

HA series **V** type

High-temperature assurance
size



Features

- Endurance : 105 °C 1000 h
- Vibration-proof product (30G guaranteed) is available upon request (ø8 ≤)
- AEC-Q200 compliant
- RoHS compliant

Specifications

Category temp. range	-40 °C to +105 °C									
Rated voltage range	6.3 V to 100 V									
Capacitance range	1 μF to 1500 μF									
Capacitance tolerance	±20 % (120 Hz / +20°C)									
Leakage current	I ≤ 0.01 CV or 3 (μA) After 2 minutes (Whichever is greater)									
Dissipation factor (tan δ)	Please see the attached characteristics list									
Characteristics at low temperature	Rated voltage (V)	6.3	10	16	25	35	50	63	100	(Impedance ratio at 120 Hz)
	Z (-25 °C) / Z (+20 °C)	4	3	2	2	2	2	3	3	
	Z (-40 °C) / Z (+20 °C)	8	6	4	4	3	3	4	4	
Endurance	After applying rated working voltage for 1000 hours at +105 °C ± 2 °C and then being stabilized at +20 °C, capacitors shall meet the following limits.									
	Capacitance change	Within ±20 % of the initial value (6.3 V of miniature : ±30 %)								
	Dissipation factor (tan δ)	≤ 200 % of the initial limit								
	DC leakage current	Within the initial limit								
Shelf life	After storage for 1000 hours at +105 °C ± 2 °C with no voltage applied and then being stabilized at +20 °C, capacitors shall meet the limits specified in endurance. (With voltage treatment)									
Resistance to soldering heat	After reflow soldering and then being stabilized at +20 °C, capacitors shall meet the following limits.									
	Capacitance change	Within ±10 % of the initial value								
	Dissipation factor (tan δ)	Within the initial limit								
	DC leakage current	Within the initial limit								

Frequency correction factor for ripple current

Frequency (Hz)	50, 60	120	1 k	10 k to
Correction factor	0.70	1.00	1.30	1.70

Marking

Example : 6.3 V 22 μF
Marking color : BLACK

Negative polarity marking (-)
 Capacitance (μF)
 Series identification
 Mark for Lead-Free products (Black dot)
 Rated voltage code
 Lot number

R.voltage code		Unit : V	
A	10	H	50
C	16	J	63
E	25	K	80
V	35	2A	100

Dimensions

0.3 max.
øD±0.5
L
A±0.2
H
I
B±0.2
W
P
K
Pressure Relief (ø10 and larger)
() Reference size

Size code	øD	L	A, B	H	I	W	P	K
B	4.0	5.4 ^{+0.1} _{-0.2}	4.3	5.5 max.	1.8	0.65±0.1	1.0	0.35 ^{+0.15} _{-0.20}
C	5.0	5.4 ^{+0.1} _{-0.2}	5.3	6.5 max.	2.2	0.65±0.1	1.5	0.35 ^{+0.15} _{-0.20}
D	6.3	5.4 ^{+0.1} _{-0.2}	6.6	7.8 max.	2.6	0.65±0.1	1.8	0.35 ^{+0.15} _{-0.20}
D8	6.3	7.7±0.3	6.6	7.8 max.	2.6	0.65±0.1	1.8	0.35 ^{+0.15} _{-0.20}
E	8.0	6.2±0.3	8.3	9.5 max.	3.4	0.65±0.1	2.2	0.35 ^{+0.15} _{-0.20}
F	8.0	10.2±0.3	8.3	10.0 max.	3.4	0.90±0.2	3.1	0.70±0.2
G	10.0	10.2±0.3	10.3	12.0 max.	3.5	0.90±0.2	4.6	0.70±0.2

Unit : mm

*The dimensions of the vibration-proof products, please refer to the page of the mounting specification.

Characteristics list

Endurance : 105 °C 1000 h

Rated voltage (V)	Capacitance (±20 %) (μF)	Case size (mm)		Size code*1	Specification		Part No.	Reflow	Min. Packaging Q'ty (pcs)
		øD	L		Ripple current*2 (mA rms)	tan δ*3			Taping
6.3	22	4.0	5.4	B	29	0.30	EEEHA0J220R	(1)	2000
	33	4.0	5.4	(B)	29	0.35	EEEHA0J330WR	(1)	2000
	47	4.0	5.4	(B)	36	0.35	EEEHA0J470WR	(1)	2000
		5.0	5.4	C	46	0.30	EEEHA0J470R	(1)	1000
	100	5.0	5.4	(C)	47	0.35	EEEHA0J101WR	(1)	1000
		6.3	5.4	D	71	0.30	EEEHA0J101P	(1)	1000
	220	6.3	5.4	(D)	74	0.35	EEEHA0J221WP	(1)	1000
	330	6.3	7.7	D8	105	0.30	EEEHA0J331XP	(1)	900
		8.0	10.2	F	230	0.35	EEEHA0J331P	(2)	500
	470	8.0	10.2	(F)	300	0.35	EEEHA0J471UP	(2)	500
1000	8.0	10.2	(F)	300	0.35	EEEHA0J102UP	(2)	500	
	10.0	10.2	G	400	0.35	EEEHA0J102P	(2)	500	
1500	10.0	10.2	G	480	0.35	EEEHA0J152P	(2)	500	
10	22	4.0	5.4	(B)	28	0.30	EEEHA1A220WR	(1)	2000
	33	4.0	5.4	(B)	29	0.30	EEEHA1A330WR	(1)	2000
		5.0	5.4	C	43	0.22	EEEHA1A330R	(1)	1000
	47	5.0	5.4	(C)	43	0.30	EEEHA1A470WR	(1)	1000
	100	6.3	5.4	(D)	71	0.30	EEEHA1A101WP	(1)	1000
		8.0	6.2	E	110	0.26	EEEHA1A101P	(2)	1000
	220	6.3	7.7	D8	105	0.22	EEEHA1A221XP	(1)	900
		8.0	10.2	F	160	0.26	EEEHA1A221P	(2)	500
	470	8.0	10.2	(F)	200	0.26	EEEHA1A471UP	(2)	500
		10.0	10.2	G	270	0.26	EEEHA1A471P	(2)	500
1000	10.0	10.2	G	400	0.26	EEEHA1A102P	(2)	500	
16	10	4.0	5.4	B	28	0.16	EEEHA1C100R	(1)	2000
	22	4.0	5.4	(B)	28	0.26	EEEHA1C220WR	(1)	2000
		5.0	5.4	C	39	0.16	EEEHA1C220R	(1)	1000
	33	5.0	5.4	(C)	35	0.26	EEEHA1C330WR	(1)	1000
	47	5.0	5.4	(C)	39	0.26	EEEHA1C470WR	(1)	1000
		6.3	5.4	D	70	0.16	EEEHA1C470P	(1)	1000
	100	6.3	5.4	(D)	70	0.26	EEEHA1C101WP	(1)	1000
		8.0	6.2	E	91	0.20	EEEHA1C101UP	(2)	1000
	220	6.3	7.7	D8	105	0.16	EEEHA1C221XP	(1)	900
		8.0	10.2	(F)	150	0.20	EEEHA1C221UP	(2)	500
		10.0	10.2	G	210	0.20	EEEHA1C221P	(2)	500
	330	8.0	10.2	(F)	170	0.20	EEEHA1C331UP	(2)	500
		10.0	10.2	G	230	0.20	EEEHA1C331P	(2)	500
	470	8.0	10.2	(F)	340	0.20	EEEHA1C471UP	(2)	500
		10.0	10.2	G	340	0.20	EEEHA1C471P	(2)	500
	680	10.0	10.2	G	380	0.20	EEEHA1C681P	(2)	500

*1: Size code() : Miniaturization product

*2: Ripple current (120 Hz / +105 °C)

*3: tan δ (120 Hz / +20 °C)

• Please refer to the page of "Reflow Profile" and "The Taping Dimensions".

• When requesting vibration-proof product, please put the last "V" instead to "P"

Characteristics list

Endurance : 105 °C 1000 h

Rated voltage (V)	Capacitance (±20 %) (μF)	Case size (mm)		Size code*1	Specification		Part No.	Reflow	Min. Packaging Q'ty (pcs)
		øD	L		Ripple current*2 (mA rms)	tan δ*3			Taping
25	4.7	4.0	5.4	B	22	0.14	EEEHA1E4R7R	(1)	2000
	10	4.0	5.4	(B)	22	0.20	EEEHA1E100WR	(1)	2000
		5.0	5.4	C	28	0.14	EEEHA1E100R	(1)	1000
	22	5.0	5.4	(C)	35	0.20	EEEHA1E220WR	(1)	1000
		6.3	5.4	D	55	0.14	EEEHA1E220P	(1)	1000
	33	5.0	5.4	(C)	45	0.20	EEEHA1E330WR	(1)	1000
		6.3	5.4	D	65	0.14	EEEHA1E330P	(1)	1000
	47	6.3	5.4	(D)	70	0.20	EEEHA1E470WP	(1)	1000
		8.0	6.2	E	91	0.16	EEEHA1E470P	(2)	1000
	100	6.3	7.7	D8	91	0.14	EEEHA1E101XP	(1)	900
		8.0	6.2	(E)	91	0.16	EEEHA1E101UP	(2)	1000
		8.0	10.2	F	130	0.16	EEEHA1E101P	(2)	500
	220	8.0	10.2	(F)	160	0.16	EEEHA1E221UP	(2)	500
		10.0	10.2	G	190	0.16	EEEHA1E221P	(2)	500
330	8.0	10.2	(F)	180	0.16	EEEHA1E331UP	(2)	500	
	10.0	10.2	G	340	0.16	EEEHA1E331P	(2)	500	
470	10.0	10.2	G	360	0.16	EEEHA1E471P	(2)	500	
35	4.7	4.0	5.4	B	22	0.12	EEEHA1V4R7R	(1)	2000
	10	4.0	5.4	(B)	22	0.16	EEEHA1V100WR	(1)	2000
		5.0	5.4	C	30	0.12	EEEHA1V100R	(1)	1000
	22	5.0	5.4	(C)	35	0.16	EEEHA1V220WR	(1)	1000
		6.3	5.4	D	60	0.12	EEEHA1V220P	(1)	1000
	33	6.3	5.4	(D)	42	0.16	EEEHA1V330WP	(1)	1000
		8.0	6.2	E	84	0.14	EEEHA1V330P	(2)	1000
	47	8.0	6.2	(E)	84	0.14	EEEHA1V470UP	(2)	1000
		8.0	10.2	F	98	0.14	EEEHA1V470P	(2)	500
	100	6.3	7.7	D8	84	0.12	EEEHA1V101XP	(1)	900
		8.0	10.2	(F)	120	0.14	EEEHA1V101UP	(2)	500
		10.0	10.2	G	160	0.14	EEEHA1V101P	(2)	500
	220	8.0	10.2	(F)	170	0.14	EEEHA1V221UP	(2)	500
		10.0	10.2	G	210	0.14	EEEHA1V221P	(2)	500
330	10.0	10.2	G	250	0.14	EEEHA1V331P	(2)	500	
50	1	4.0	5.4	B	10	0.12	EEEHA1H1R0R	(1)	2000
	2.2	4.0	5.4	B	16	0.12	EEEHA1H2R2R	(1)	2000
	3.3	4.0	5.4	B	16	0.12	EEEHA1H3R3R	(1)	2000
	4.7	5.0	5.4	C	23	0.12	EEEHA1H4R7R	(1)	1000
	10	6.3	5.4	D	35	0.12	EEEHA1H100P	(1)	1000
	22	8.0	6.2	E	70	0.12	EEEHA1H220P	(2)	1000
		6.3	7.7	D8	70	0.12	EEEHA1H330XP	(1)	900
	33	8.0	6.2	(E)	70	0.12	EEEHA1H330UP	(2)	1000
		8.0	10.2	F	91	0.12	EEEHA1H330P	(2)	500
		6.3	7.7	D8	63	0.12	EEEHA1H470XP	(1)	900
	47	8.0	10.2	(F)	95	0.12	EEEHA1H470UP	(2)	500
		10.0	10.2	G	100	0.12	EEEHA1H470P	(2)	500
	100	8.0	10.2	(F)	110	0.12	EEEHA1H101UP	(2)	500
		10.0	10.2	G	120	0.12	EEEHA1H101P	(2)	500
220	10.0	10.2	G	150	0.12	EEEHA1H221P	(2)	500	

*1: Size code() : Miniaturization product

*2: Ripple current (120 Hz / +105 °C)

*3: tanδ (120 Hz / +20 °C)

• Please refer to the page of "Reflow Profile" and "The Taping Dimensions".

• When requesting vibration-proof product, please put the last "V" instead to "P"

Characteristics list

Endurance : 105 °C 1000 h

Rated voltage (V)	Capacitance (±20 %) (μF)	Case size (mm)		Size code ^{*1}	Specification		Part No.	Reflow	Min. Packaging Q'ty (pcs)
		øD	L		Ripple current ^{*2} (mA rms)	tan δ ^{*3}			Taping
63	10	8.0	6.2	E	25	0.18	EEEHA1J100P	(2)	1000
	22	8.0	6.2	(E)	25	0.18	EEEHA1J220UP	(2)	1000
		8.0	10.2	F	30	0.18	EEEHA1J220P	(2)	500
	33	10.0	10.2	G	45	0.18	EEEHA1J330P	(2)	500
	47	8.0	10.2	(F)	45	0.18	EEEHA1J470UP	(2)	500
		10.0	10.2	G	50	0.18	EEEHA1J470P	(2)	500
100	4.7	8.0	6.2	(E)	30	0.18	EEEHA2A4R7UP	(2)	1000
	10	8.0	10.2	F	55	0.18	EEEHA2A100P	(2)	500
	22	8.0	10.2	(F)	55	0.18	EEEHA2A220UP	(2)	500
		10.0	10.2	G	60	0.18	EEEHA2A220P	(2)	500
	33	10.0	10.2	G	65	0.18	EEEHA2A330P	(2)	500
	47	10.0	10.2	(G)	65	0.18	EEEHA2A470UP	(2)	500

*1: Size code() : Miniaturization product

*2: Ripple current (120 Hz / +105 °C)

*3: tanδ (120 Hz / +20 °C)

• Please refer to the page of "Reflow Profile" and "The Taping Dimensions".

• When requesting vibration-proof product, please put the last "V" instead to "P"

Surface Mount Type

HB series **V** type

High temperature Lead-Free reflow (suffix : A*)



Features

- Endurance : 105 °C 2000 h
- Vibration-proof product (30G guaranteed) is available upon request. (ø8 ≤)
- AEC-Q200 compliant
- RoHS compliant

Specifications

Category temp. range	-40 °C to +105 °C								
Rated voltage range	6.3 V to 50 V								
Capacitance range	1 µF to 1500 µF								
Capacitance tolerance	±20 % (120 Hz / +20 °C)								
Leakage current	I ≤ 0.01 CV or 3 (µA) After 2 minutes (Whichever is greater)								
Dissipation factor (tan δ)	Please see the attached characteristics list								
Characteristics at low temperature	Standard	Rated voltage (V)	6.3	10	16	25	35	50	(Impedance ratio at 120 Hz)
		Z (-25 °C) / Z (+20 °C)	4	3	2	2	2	2	
	Miniaturization product	Z (-25 °C) / Z (+20 °C)	8	6	4	4	3	3	
		Z (-40 °C) / Z (+20 °C)	4	3	2	2	2	2	
Endurance	After applying rated working voltage for 2000 h at +105 °C ± 2 °C and then being stabilized at +20 °C, capacitors shall meet the following limits.								
	Capacitance change	Within ±20 % of the initial value (16 V or less : Within ±25 %, Miniaturization product : Within ±35 %)							
	Dissipation factor (tan δ)	≤200 % of the initial limit							
	Leakage current	Within the initial limit							
Shelf life	After storage for 1000 h at +105 °C ± 2 °C with no voltage applied and then being stabilized at +20 °C, capacitors shall meet the limits specified in endurance. (With voltage treatment)								
Resistance to soldering heat	After reflow soldering and then being stabilized at +20 °C, capacitors shall meet the following limits.								
	Capacitance change	Within ±10 % of the initial value							
	Dissipation factor (tan δ)	Within the initial limit							
	Leakage current	Within the initial limit							

Frequency correction factor for ripple current

Frequency (Hz)	50, 60	120	1 k	10 k to
Correction factor	0.70	1.00	1.30	1.70

Marking

Example : 6.3 V 22 µF
Marking color : BLACK

Negative polarity marking (-)

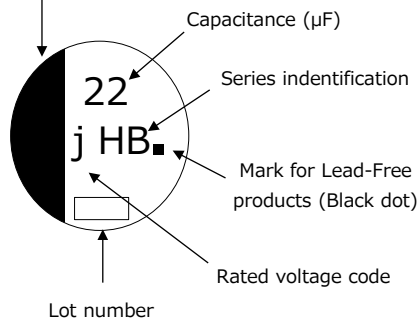

R. voltage code		Unit : V	
j	6.3	E	25
A	10	V	35
C	16	H	50

Dimensions

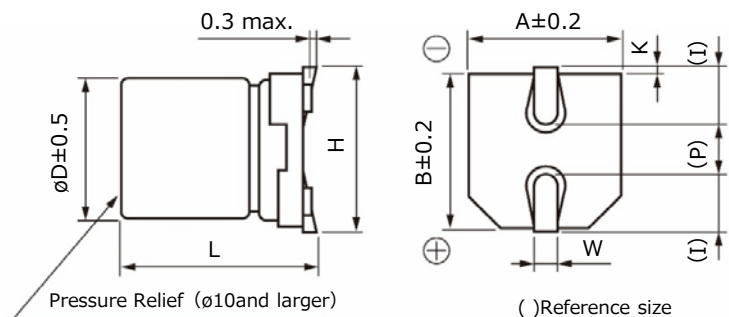

Size code	øD	L	A, B	H	I	W	P	K
B	4.0	5.8±0.3	4.3	5.5 max.	1.8	0.65±0.1	1.0	0.35 ^{+0.15} _{-0.20}
C	5.0	5.8±0.3	5.3	6.5 max.	2.2	0.65±0.1	1.5	0.35 ^{+0.15} _{-0.20}
D	6.3	5.8±0.3	6.6	7.8 max.	2.6	0.65±0.1	1.8	0.35 ^{+0.15} _{-0.20}
D8	6.3	7.7±0.3	6.6	7.8 max.	2.6	0.65±0.1	1.8	0.35 ^{+0.15} _{-0.20}
E	8.0	6.2±0.3	8.3	9.5 max.	3.4	0.65±0.1	2.2	0.35 ^{+0.15} _{-0.20}
F	8.0	10.2±0.3	8.3	10.0 max.	3.4	0.90±0.2	3.1	0.70±0.2
G	10.0	10.2±0.3	10.3	12.0 max.	3.5	0.90±0.2	4.6	0.70±0.2

*The dimensions of the vibration-proof products, please refer to the page of the mounting specification.

Characteristics list

Endurance : 105 °C 2000 h

Rated voltage (V)	Capacitance (±20 %) (μF)	Case size (mm)		Size code*1	Specification		Part No.	Reflow	Min. Packaging Q'ty (pcs)
		øD	L		Ripple current*2 (mA rms)	tan δ*3			Taping
6.3	22	4.0	5.8	B	26	0.30	EEEHB0J220AR	(5)	2000
	33	4.0	5.8	B	29	0.30	EEEHB0J330AR	(5)	2000
	47	4.0	5.8	(B)	26	0.50	EEEHB0J470UAR	(5)	2000
					46	0.30	EEEHB0J470AR	(5)	1000
	100	5.0	5.8	(C)	42	0.50	EEEHBJ101UAR	(5)	1000
					71	0.30	EEEHB0J101AP	(5)	1000
	220	6.3	5.8	(D)	80	0.50	EEEHBJ221UAP	(5)	1000
					150	0.35	EEEHB0J221AP	(7)	500
	330	8.0	6.2	(E)	180	0.50	EEEHBJ331UAP	(7)	1000
					230	0.35	EEEHB0J331AP	(7)	500
470	8.0	10.2	(F)	230	0.50	EEEHB0J471UAP	(7)	500	
1500	10.0	10.2	(G)	290	0.50	EEEHBJ152UAP	(7)	500	
10	33	4.0	5.8	(B)	23	0.30	EEEHBA330UAR	(5)	2000
		5.0	5.8	C	43	0.26	EEEHB1A330AR	(5)	1000
	68	6.3	5.8	D	70	0.22	EEEHB1A680AP	(5)	1000
	100	6.3	5.8	(D)	71	0.30	EEEHBA101UAP	(5)	1000
		8.0	6.2	E	110	0.26	EEEHB1A101AP	(7)	1000
	150	6.3	5.8	(D)	64	0.50	EEEHBA151UAP	(5)	1000
	220	8.0	6.2	(E)	110	0.30	EEEHBA221UAP	(7)	1000
		8.0	10.2	F	160	0.26	EEEHB1A221AP	(7)	500
	470	8.0	10.2	(F)	220	0.35	EEEHBA471UAP	(7)	500
		10.0	10.2	G	270	0.26	EEEHB1A471AP	(7)	500
16	10	4.0	5.8	B	28	0.16	EEEHB1C100AR	(5)	2000
	22	4.0	5.8	(B)	29.5	0.26	EEEHBC220UAR	(5)	2000
		5.0	5.8	C	39	0.16	EEEHB1C220AR	(5)	1000
	33	6.3	5.8	D	65	0.16	EEEHB1C330AP	(5)	1000
	47	5.0	5.8	(C)	39	0.26	EEEHBC470UAR	(5)	1000
		6.3	5.8	D	70	0.16	EEEHB1C470AP	(5)	1000
	100	6.3	7.7	D8	84	0.16	EEEHBC470XAP	(5)	900
		6.3	5.8	(D)	70	0.26	EEEHBC101UAP	(5)	1000
	220	8.0	10.2	F	120	0.20	EEEHB1C101AP	(7)	500
		8.0	10.2	(F)	150	0.20	EEEHBC221UAP	(7)	500
	330	10.0	10.2	G	210	0.20	EEEHB1C221AP	(7)	500
		10.0	10.2	G	230	0.20	EEEHB1C331AP	(7)	500
	470	8.0	10.2	(F)	240	0.40	EEEHBC471UAP	(7)	500
		10.0	10.2	G	340	0.20	EEEHB1C471AP	(7)	500
25	4.7	4.0	5.8	B	22	0.14	EEEHB1E4R7AR	(5)	2000
	6.8	4.0	5.8	B	25	0.14	EEEHB1E6R8AR	(5)	2000
	10	4.0	5.8	(B)	28	0.16	EEEHBE100UAR	(5)	2000
		5.0	5.8	C	28	0.14	EEEHB1E100AR	(5)	1000
	22	6.3	5.8	D	55	0.14	EEEHB1E220AP	(5)	1000
	33	5.0	5.8	(C)	50	0.20	EEEHBE330UAR	(5)	1000
		6.3	5.8	D	65	0.14	EEEHB1E330AP	(5)	1000
	47	6.3	5.8	(D)	65	0.20	EEEHBE470UAR	(5)	1000
		8.0	6.2	E	91	0.16	EEEHB1E470AP	(7)	1000
	100	8.0	6.2	(E)	100	0.16	EEEHBE101UAP	(7)	1000
		8.0	10.2	F	130	0.16	EEEHB1E101AP	(7)	500
	220	8.0	10.2	(F)	130	0.30	EEEHBE221UAP	(7)	500
		10.0	10.2	G	190	0.16	EEEHB1E221AP	(7)	500
	330	8.0	10.2	(F)	130	0.30	EEEHBE331UAP	(7)	500
		10.0	10.2	G	220	0.16	EEEHB1E331AP	(7)	500
	470	10.0	10.2	(G)	230	0.30	EEEHBE471UAP	(7)	500

*1: Size code() : Miniaturization product

*2: Ripple current (120 Hz / +105 °C)

*3: tanδ (120 Hz / +20 °C)

• Please refer to the page of "Reflow Profile" and "The Taping Dimensions".

• When requesting vibration-proof product, please put the last "V" instead to "P"

Characteristics list

Endurance : 105 °C 2000 h

Rated voltage (V)	Capacitance (±20 %) (μF)	Case size (mm)		Size code ^{*1}	Specification		Part No.	Reflow	Min. Packaging Q'ty (pcs)	
		øD	L		Ripple current ^{*2} (mA rms)	tan δ ^{*3}			Taping	
35	4.7	4.0	5.8	B	21	0.12	EEEHB1V4R7AR	(5)	2000	
	6.8	4.0	5.8	(B)	25	0.12	EEEHBV6R8UAR	(5)	2000	
	10	5.0	5.8	C	28	0.12	EEEHB1V100AR	(5)	1000	
	22	6.3	5.8	D	55	0.12	EEEHB1V220AP	(5)	1000	
	33	8.0	6.2	E	84	0.14	EEEHB1V330AP	(7)	1000	
	47	47	6.3	7.7	D8	98	0.20	EEEHBV470YAP	(5)	900
			8.0	6.2	(E)	91	0.18	EEEHBV470UAP	(7)	1000
			8.0	10.2	F	98	0.14	EEEHB1V470AP	(7)	500
	100	100	8.0	10.2	(F)	98	0.20	EEEHBV101UAP	(7)	500
			10.0	10.2	G	160	0.14	EEEHB1V101AP	(7)	500
220	10.0	10.2	(G)	180	0.14	EEEHBV221UAP	(7)	500		
50	1	4.0	5.8	B	10	0.12	EEEHB1H1R0AR	(5)	2000	
	2.2	4.0	5.8	B	16	0.12	EEEHB1H2R2AR	(5)	2000	
	3.3	4.0	5.8	B	16	0.12	EEEHB1H3R3AR	(5)	2000	
	4.7	5.0	5.8	C	23	0.12	EEEHB1H4R7AR	(5)	1000	
	6.8	5.0	5.8	C	23	0.12	EEEHB1H6R8AR	(5)	1000	
	10	6.3	5.8	D	35	0.12	EEEHB1H100AP	(5)	1000	
	22	22	6.3	5.8	(D)	35	0.14	EEEHBH220UAP	(5)	1000
			8.0	6.2	E	70	0.12	EEEHB1H220AP	(7)	1000
	33	8.0	10.2	F	91	0.12	EEEHB1H330AP	(7)	500	
	47	47	6.3	7.7	D8	63	0.12	EEEHBH470YAP	(5)	900
			8.0	10.2	(F)	95	0.12	EEEHBH470UAP	(7)	500
			10.0	10.2	G	100	0.12	EEEHB1H470AP	(7)	500
	100	10.0	10.2	(G)	250	0.12	EEEHBH101UAP	(7)	500	
220	10.0	10.2	(G)	270	0.18	EEEHBH221UAP	(7)	500		

*1: Size code() : Miniaturization product

*2: Ripple current (120 Hz / +105 °C)

*3: tanδ (120 Hz / +20 °C)

- Please refer to the page of "Reflow Profile" and "The Taping Dimensions".
- When requesting vibration-proof product, please put the last "V" instead to "P"

Surface Mount Type

HB series **V** type

Long life

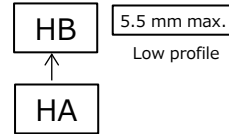

Features

- Endurance : 105 °C 2000 h
- 5.8 mm height (≦ ø6.3), 5.5 mm height max.
- Vibration-proof product (30G guaranteed) is available upon request. (ø8 ≦)
- AEC-Q200 compliant
- RoHS compliant

Specifications

Category temp. range	-40 °C to +105 °C								
Rated voltage range	4.0 V to 50 V								
Capacitance range	1 μF to 470 μF								
Capacitance tolerance	±20 % (120 Hz / +20 °C)								
Leakage current	I ≦ 0.01 CV or 3 (μA) After 2 minutes (Bi-polar I ≦ 0.02 CV or 6 (μA) after 2 minutes) (Whichever is greater)								
Dissipation factor (tan δ)	Please see the attached characteristics list								
Characteristics at low temperature	Rated voltage (V)	4	6.3	10	16	25	35	50	(Impedance ratio at 120 Hz)
	Z (-25 °C) / Z (+20 °C)	7	4	3	2	2	2	2	
	Z (-40 °C) / Z (+20 °C)	15	8	6	4	4	3	3	
Endurance	After applying rated working voltage for 2000 h (Bi-polar:1000 h for each polarity) at +105 °C ± 2 °C and then being stabilized at +20 °C, capacitors shall meet the following limits.								
	Capacitance change	Within ±20 % of the initial value (4 V : ±35 % 6.3 V : ±25 % 04 to 06.3), 5.5 mm max. : ±25 %							
	Dissipation factor (tan δ)	≦200 % of the initial limit							
	Leakage current	Within the initial limit							
Shelf life	After storage for 1000 h at +105 °C ± 2 °C with no voltage applied and then being stabilized at +20 °C, capacitors shall meet the limits specified in endurance. (With voltage treatment)								
Resistance to soldering heat	After reflow soldering and then being stabilized at +20 °C, capacitors shall meet the following limits.								
	Capacitance change	Within ±10 % of the initial value							
	Dissipation factor (tan δ)	Within the initial limit							
	Leakage current	Within the initial limit							

Frequency correction factor for ripple current

Frequency (Hz)	50, 60	120	1 k	10 k to
Correction factor	0.70	1.00	1.30	1.70

Marking

Example : 4.0 V 47 μF
Marking color : BLACK

Negative polarity marking (-)
(No marking for the bi-polar)

Capacitance (μF)

Series identification
(HP : Bi-polar)
(BS : 5.5 mm max.)

Mark for Lead-Free products (Black dot)

Rated voltage code

Lot number

R. voltage code		Unit : V	
g	4.0	E	25
j	6.3	V	35
A	10	H	50
C	16		

Dimensions

() Reference size

Unit : mm

Size code	øD	L	A,B	H	I	W	P	K
B	4.0	5.8±0.3	4.3	5.5 max.	1.8	0.65±0.1	1.0	0.35 ^{+0.15} _{-0.20}
C	5.0	5.8±0.3	5.3	6.5 max.	2.2	0.65±0.1	1.5	0.35 ^{+0.15} _{-0.20}
D	6.3	5.8±0.3	6.6	7.8 max.	2.6	0.65±0.1	1.8	0.35 ^{+0.15} _{-0.20}
E	8.0	6.2±0.3	8.3	9.5 max.	3.4	0.65±0.1	2.2	0.35 ^{+0.15} _{-0.20}
F	8.0	10.2±0.3	8.3	10.0 max.	3.4	0.90±0.2	3.1	0.70±0.2
G	10.0	10.2±0.3	10.3	12.0 max.	3.5	0.90±0.2	4.6	0.70±0.2

● Low profile (L=5.5 mm max.)

Size code	øD	L	A,B	H	I	W	P	K
B	4.0	5.4 ^{+0.1} _{-0.2}	4.3	5.5 max.	1.8	0.65±0.1	1.0	0.35 ^{+0.15} _{-0.20}
C	5.0	5.4 ^{+0.1} _{-0.2}	5.3	6.5 max.	2.2	0.65±0.1	1.5	0.35 ^{+0.15} _{-0.20}
D	6.3	5.4 ^{+0.1} _{-0.2}	6.6	7.8 max.	2.6	0.65±0.1	1.8	0.35 ^{+0.15} _{-0.20}

*The dimensions of the vibration-proof products, please refer to the page of the mounting specification.

Characteristics list

Endurance : 105 °C 2000 h

Rated voltage (V)	Capacitance (±20 %) (μF)	Case size (mm)		Size code	Specification		Part No.	Reflow	Min. Packaging Q'ty (pcs)
		øD	L		Ripple current* ¹ (mA rms)	tan δ* ²			Taping
4	47	4.0	5.8	B	34	0.50	EEEHB0G470R	(1)	2000
	100	5.0	5.8	C	61	0.50	EEEHB0G101R	(1)	1000
	150	6.3	5.8	D	82	0.50	EEEHB0G151P	(1)	1000
	220	6.3	5.8	D	82	0.50	EEEHB0G221P	(1)	1000
6.3	22	4.0	5.8	B	26	0.30	EEEHB0J220R	(1)	2000
	33	4.0	5.8	B	29	0.30	EEEHB0J330R	(1)	2000
	47	5.0	5.8	C	46	0.30	EEEHB0J470R	(1)	1000
	100	6.3	5.8	D	71	0.30	EEEHB0J101P	(1)	1000
	220	8.0	10.2	F	150	0.35	EEEHB0J221P	(2)	500
	330	8.0	10.2	F	230	0.35	EEEHB0J331P	(2)	500
10	33	5.0	5.8	C	43	0.22	EEEHB1A330R	(1)	1000
	100	8.0	6.2	E	110	0.26	EEEHB1A101P	(2)	1000
	220	8.0	10.2	F	160	0.26	EEEHB1A221P	(2)	500
	470	10.0	10.2	G	270	0.26	EEEHB1A471P	(2)	500
16	10	4.0	5.8	B	28	0.16	EEEHB1C100R	(1)	2000
	22	5.0	5.8	C	39	0.16	EEEHB1C220R	(1)	1000
	47	6.3	5.8	D	70	0.16	EEEHB1C470P	(1)	1000
	100	8.0	10.2	F	120	0.20	EEEHB1C101P	(2)	500
	220	10.0	10.2	G	210	0.20	EEEHB1C221P	(2)	500
	330	10.0	10.2	G	230	0.20	EEEHB1C331P	(2)	500
25	4.7	4.0	5.8	B	22	0.14	EEEHB1E4R7R	(1)	2000
	6.8	4.0	5.8	B	25	0.14	EEEHB1E6R8R	(1)	2000
	33	6.3	5.8	D	65	0.14	EEEHB1E330P	(1)	1000
	47	8.0	6.2	E	91	0.16	EEEHB1E470P	(2)	1000
	100	8.0	10.2	F	130	0.16	EEEHB1E101P	(2)	500
	220	10.0	10.2	G	190	0.16	EEEHB1E221P	(2)	500
35	10	5.0	5.8	C	28	0.12	EEEHB1V100R	(1)	1000
	22	6.3	5.8	D	55	0.12	EEEHB1V220P	(1)	1000
	33	8.0	6.2	E	84	0.14	EEEHB1V330P	(2)	1000
	47	8.0	10.2	F	98	0.14	EEEHB1V470P	(2)	500
	100	10.0	10.2	G	160	0.14	EEEHB1V101P	(2)	500
50	1	4.0	5.8	B	10	0.12	EEEHB1H1R0R	(1)	2000
	2.2	4.0	5.8	B	16	0.12	EEEHB1H2R2R	(1)	2000
	3.3	4.0	5.8	B	16	0.12	EEEHB1H3R3R	(1)	2000
	4.7	5.0	5.8	C	23	0.12	EEEHB1H4R7R	(1)	1000
	6.8	5.0	5.8	C	23	0.12	EEEHB1H6R8R	(1)	1000
	10	6.3	5.8	D	35	0.12	EEEHB1H100P	(1)	1000
	22	8.0	6.2	E	70	0.12	EEEHB1H220P	(2)	1000
	33	8.0	10.2	F	91	0.12	EEEHB1H330P	(2)	500
47	10.0	10.2	G	100	0.12	EEEHB1H470P	(2)	500	

*1: Ripple current (120 Hz / +105 °C)

*2: tanδ (120 Hz / +20 °C)

• Please refer to the page of "Reflow Profile" and "The Taping Dimensions".

• When requesting vibration-proof product, please put the last "V" instead to "P"

Characteristics list (Bi-polar)

Endurance : 105 °C 2000 h

Rated voltage (V)	Capacitance (±20 %) (μF)	Case size (mm)		Size code	Specification		Part No.	Reflow	Min. Packaging Q'ty (pcs)
		øD	L		Ripple current* ¹ (mA rms)	tan δ* ²			Taping
6.3	47	6.3	5.8	D	35	0.60	EEEHP0J470P	(1)	1000
10	10	4.0	5.8	B	20	0.44	EEEHP1A100R	(1)	2000
	33	6.3	5.8	D	26	0.44	EEEHP1A330P	(1)	1000
16	10	5.0	5.8	C	25	0.32	EEEHP1C100R	(1)	1000
25	3.3	4.0	5.8	B	12	0.28	EEEHP1E3R3R	(1)	2000
	4.7	4.0	5.8	B	12	0.28	EEEHP1E4R7R	(1)	2000
	10	6.3	5.8	D	28	0.28	EEEHP1E100P	(1)	1000
	22	6.3	5.8	D	55	0.28	EEEHP1E220P	(1)	1000
35	2.2	4.0	5.8	B	10	0.24	EEEHP1V2R2R	(1)	2000
50	1	4.0	5.8	B	10	0.24	EEEHP1H1R0R	(1)	2000
	3.3	6.3	5.8	D	16	0.24	EEEHP1H3R3P	(1)	1000
	4.7	6.3	5.8	D	23	0.24	EEEHP1H4R7P	(1)	1000

Characteristics list (5.5 mm max.)

Endurance : 105 °C 2000 h

Rated voltage (V)	Capacitance (±20 %) (μF)	Case size (mm)		Size code	Specification		Part No.	Reflow	Min. Packaging Q'ty (pcs)
		øD	L		Ripple current* ¹ (mA rms)	tan δ* ²			Taping
6.3	22	4.0	5.4	B	26	0.30	EEEHB0J220SR	(1)	2000
	47	5.0	5.4	C	46	0.30	EEEHB0J470SR	(1)	1000
	100	6.3	5.4	D	71	0.30	EEEHB0J101SP	(1)	1000
10	33	5.0	5.4	C	43	0.22	EEEHB1A330SR	(1)	1000
16	10	4.0	5.4	B	28	0.16	EEEHB1C100SR	(1)	2000
	22	5.0	5.4	C	39	0.16	EEEHB1C220SR	(1)	1000
	47	6.3	5.4	D	70	0.16	EEEHB1C470SP	(1)	1000
25	4.7	4.0	5.4	B	22	0.14	EEEHB1E4R7SR	(1)	2000
	6.8	4.0	5.4	B	25	0.14	EEEHB1E6R8SR	(1)	2000
	33	6.3	5.4	D	65	0.14	EEEHB1E330SP	(1)	1000
35	10	5.0	5.4	C	28	0.12	EEEHB1V100SR	(1)	1000
	22	6.3	5.4	D	55	0.12	EEEHB1V220SP	(1)	1000
50	1	4.0	5.4	B	10	0.12	EEEHB1H1R0SR	(1)	2000
	2.2	4.0	5.4	B	16	0.12	EEEHB1H2R2SR	(1)	2000
	3.3	4.0	5.4	B	16	0.12	EEEHB1H3R3SR	(1)	2000
	4.7	5.0	5.4	C	23	0.12	EEEHB1H4R7SR	(1)	1000
	6.8	5.0	5.4	C	23	0.12	EEEHB1H6R8SR	(1)	1000
	10	6.3	5.4	D	35	0.12	EEEHB1H100SP	(1)	1000

*1: Ripple current (120 Hz / +105 °C)

*2: tanδ (120 Hz / +20 °C)

• Please refer to the page of "Reflow Profile" and "The Taping Dimensions".

• When requesting vibration-proof product, please put the last "V" instead to "P"

Surface Mount Type

HC series V type

Long life

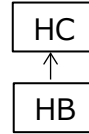

Features

- Endurance : 105 °C 3000 h to 5000 h
- Vibration-proof productt (30G guaranteed) is available upon request (ø8 ≤)
- AEC-Q200 compliant
- RoHS compliant

Specifications

Category temp. range	-40 °C to +105 °C	
Rated voltage range	6.3 V to 50 V	
Capacitance range	1 μF to 1000 μF	
Capacitance tolerance	±20 % (120 Hz / +20 °C)	
Leakage current	I ≤ 0.01 CV or 3 (μA) After 2 minutes (Whichever is greater)	
Dissipation factor (tan δ)	Please see the attached characteristics list	
Endurance	After applying rated working voltage for 2000 hours at +105 °C ± 2 °C and then being stabilized at +20 °C, capacitors shall meet the following limits. ø4 to ø6.3 (3000 hours After applying rated working voltage) ø8 to ø10 (5000 hours After applying rated working voltage)	
	Capacitance change	Within ±30 % of the initial value
	Dissipation factor (tan δ)	≤ 300 % of the initial limit
	Leakage current	Within the initial limit
Shelf life	After storage for 1000 hours at +105 °C ± 2 °C with no voltage applied and then being stabilized at +20 °C, capacitors shall meet the limits specified in endurance. (With voltage treatment)	
	Capacitance change	Within ±10 % of the initial value
Resistance to soldering heat	Dissipation factor (tan δ)	Within the initial limit
	Leakage current	Within the initial limit

Frequency correction factor for ripple current

Frequency (Hz)	50, 60	120	1 k	10 k to
Correction factor	0.70	1.00	1.30	1.70

Marking

Example : 6.3 V 22 μF
Marking color : BLACK

Negative polarity marking (-)

Capacitance (μF)

Series identification

Mark for Lead-Free products (Black dot)

Rated voltage code

Lot number

R.voltage code		Unit : V	
j	6.3	E	25
A	10	V	35
C	16	H	50

Dimensions

0.3 max.

øD±0.5

L

A±0.2

H

I

W

P

K

(T)

Pressure Relief (ø10 and larger)

(T) Reference size

Unit : mm

Size code	øD	L	A, B	H	I	W	P	K
B	4.0	5.8±0.3	4.3	5.5 max.	1.8	0.65±0.1	1.0	0.35 ^{+0.15} _{-0.20}
C	5.0	5.8±0.3	5.3	6.5 max.	2.2	0.65±0.1	1.5	0.35 ^{+0.15} _{-0.20}
D	6.3	5.8±0.3	6.6	7.8 max.	2.6	0.65±0.1	1.8	0.35 ^{+0.15} _{-0.20}
D8	6.3	7.7±0.3	6.6	7.8 max.	2.6	0.65±0.1	1.8	0.35 ^{+0.15} _{-0.20}
F	8.0	10.2±0.3	8.3	10.0 max.	3.4	0.90±0.2	3.1	0.70±0.2
G	10.0	10.2±0.3	10.3	12.0 max.	3.5	0.90±0.2	4.6	0.70±0.2

*The dimensions of the vibration-proof products, please refer to the page of the mounting specification.

Characteristics list

Endurance : 105 °C 3000 h (ø8, ø10 : 5000 h)

Rated voltage (V)	Capacitance (±20 %) (μF)	Case size (mm)		Size code	Specification		Part No.	Reflow	Min. Packaging Q'ty (pcs)
		øD	L		Ripple current* ¹ (mA rms)	tan δ* ²			Taping
6.3	22	4.0	5.8	B	26	0.30	EEEHC0J220R	(1)	2000
	47	5.0	5.8	C	46	0.30	EEEHC0J470R	(1)	1000
	100	6.3	5.8	D	71	0.30	EEEHC0J101P	(1)	1000
	220	6.3	7.7	D8	101	0.30	EEEHC0J221XP	(1)	900
	330	8.0	10.2	F	230	0.30	EEEHC0J331P	(2)	500
	1000	10.0	10.2	G	313	0.50	EEEHC0J102P	(2)	500
10	33	5.0	5.8	C	43	0.26	EEEHC1A330R	(1)	1000
	220	8.0	10.2	F	160	0.26	EEEHC1A221P	(2)	500
16	10	4.0	5.8	B	28	0.20	EEEHC1C100R	(1)	2000
	22	5.0	5.8	C	39	0.20	EEEHC1C220R	(1)	1000
	47	6.3	5.8	D	70	0.20	EEEHC1C470P	(1)	1000
	100	6.3	7.7	D8	81	0.20	EEEHC1C101XP	(1)	900
	470	10.0	10.2	G	340	0.20	EEEHC1C471P	(2)	500
25	33	6.3	5.8	D	65	0.16	EEEHC1E330P	(1)	1000
	47	6.3	7.7	D8	65	0.16	EEEHC1E470XP	(1)	900
	100	8.0	10.2	F	130	0.16	EEEHC1E101P	(2)	500
	330	10.0	10.2	G	238	0.16	EEEHC1E331P	(2)	500
35	4.7	4.0	5.8	B	15	0.14	EEEHC1V4R7R	(1)	2000
	10	5.0	5.8	C	28	0.14	EEEHC1V100R	(1)	1000
	22	6.3	5.8	D	55	0.14	EEEHC1V220P	(1)	1000
	33	6.3	7.7	D8	57	0.14	EEEHC1V330XP	(1)	900
	220	10.0	10.2	G	220	0.14	EEEHC1V221P	(2)	500
50	1	4.0	5.8	B	10	0.12	EEEHC1H1R0R	(1)	2000
	2.2	4.0	5.8	B	16	0.12	EEEHC1H2R2R	(1)	2000
	3.3	4.0	5.8	B	16	0.12	EEEHC1H3R3R	(1)	2000
	4.7	5.0	5.8	C	23	0.12	EEEHC1H4R7R	(1)	1000
	10	6.3	5.8	D	35	0.12	EEEHC1H100P	(1)	1000
	22	6.3	7.7	D8	49	0.12	EEEHC1H220XP	(1)	900
	33	8.0	10.2	F	91	0.12	EEEHC1H330P	(2)	500
	47	8.0	10.2	F	100	0.12	EEEHC1H470P	(2)	500
	100	10.0	10.2	G	160	0.12	EEEHC1H101P	(2)	500

*1: Ripple current (120 Hz / +105 °C)

*2: tanδ (120 Hz / +20 °C)

- Please refer to the page of "Reflow Profile" and "The Taping Dimensions".
- When requesting vibration-proof product, please put the last "V" instead to "P"

Surface Mount Type

HD series **V** type

6.3 V to 35 V : High temperature Lead-Free reflow (suffix : A*)

50 V to 100 V : Standard Lead-Free reflow



Features

- Endurance : 105 °C 5000 h
- Vibration-proof product (30G guaranteed) is available upon request ($\phi 6.3 \leq$)
- AEC-Q200 compliant
- RoHS compliant

Specifications

Category temp. range	-40 °C to +105 °C									
Rated voltage range	6.3 V to 100 V									
Capacitance range	1 μ F to 1000 μ F									
Capacitance tolerance	± 20 % (120 Hz / +20 °C)									
Leakage current	$I \leq 0.01 CV$ or 3 (μ A) After 2 minutes (Whichever is greater)									
Dissipation factor (tan δ)	Please see the attached characteristics list									
Characteristics at low temperature	Rated voltage (V)	6.3	10	16	25	35	50	63	100	(Impedance ratio at 120 Hz)
	Z (-25 °C) / Z (+20 °C)	3	3	2	2	2	2	2	2	
	Z (-40 °C) / Z (+20 °C)	4	4	3	3	3	3	3	3	
Endurance	After applying rated working voltage for 5000 hours at +105 °C ± 2 °C and then being stabilized at +20 °C, capacitors shall meet the following limits.									
	Capacitance change	Within ± 30 % of the initial value								
	Dissipation factor (tan δ)	≤ 300 % of the initial limit								
	Leakage current	Within the initial limit								
Shelf life	After storage for 1000 hours at +105 °C ± 2 °C with no voltage applied and then being stabilized at +20 °C, capacitors shall meet the limits specified in endurance. (With voltage treatment)									
	Capacitance change	Within ± 20 % of the initial value								
	Dissipation factor (tan δ)	≤ 200 % of the initial limit								
	Leakage current	Within the initial limit								
Resistance to soldering heat	After reflow soldering and then being stabilized at +20 °C, capacitors shall meet the following limits.									
	Capacitance change	Within ± 10 % of the initial value								
	Dissipation factor (tan δ)	Within the initial limit								
	Leakage current	Within the initial limit								

Frequency correction factor for ripple current

Frequency (Hz)	50, 60	120	1 k	10 k to
Correction factor	0.70	1.00	1.30	1.70

Marking

Example : 6.3 V 330 μ F
Marking color : BLACK

Negative polarity marking (-)

Capacitance (μ F)

Series identification

Mark for Lead-Free products (Black dot)

Rated voltage code

Lot number

R.voltage code		Unit : V	
j	6.3	V	35
A	10	H	50
C	16	J	63
E	25	2A	100

Dimensions

Pressure Relief ($\phi 10$ and larger)

() Reference size

Unit : mm

Size code	ϕD	L	A, B	H	I	W	P	K
B	4.0	5.8 \pm 0.3	4.3	5.5 max.	1.8	0.65 \pm 0.1	1.0	0.35 ^{+0.15} _{-0.20}
C	5.0	5.8 \pm 0.3	5.3	6.5 max.	2.2	0.65 \pm 0.1	1.5	0.35 ^{+0.15} _{-0.20}
D	6.3	5.8 \pm 0.3	6.6	7.8 max.	2.6	0.65 \pm 0.1	1.8	0.35 ^{+0.15} _{-0.20}
D8	6.3	7.7 \pm 0.3	6.6	7.8 max.	2.6	0.65 \pm 0.1	1.8	0.35 ^{+0.15} _{-0.20}
E	8.0	6.2 \pm 0.3	8.3	9.5 max.	3.4	0.65 \pm 0.1	2.2	0.35 ^{+0.15} _{-0.20}
F	8.0	10.2 \pm 0.3	8.3	10.0 max.	3.4	0.90 \pm 0.2	3.1	0.70 \pm 0.2
G	10.0	10.2 \pm 0.3	10.3	12.0 max.	3.5	0.90 \pm 0.2	4.6	0.70 \pm 0.2

*The dimensions of the vibration-proof products, please refer to the page of the mounting specification.

Characteristics list

■ 6.3 V to 35 V (High temperature reflow)

Endurance : 105 °C 5000 h

Rated voltage (V)	Capacitance (±20 %) (μF)	Case size (mm)		Size code	Specification			Part No.	Reflow	Min. Packaging Q'ty (pcs)
		øD	L		Ripple current* ¹ (mA rms)	Impedance* ² (Ω)	tanδ* ³			Taping
6.3	330	8.0	10.2	F	230	1.5	0.30	EEEHD0J331AP	(7)	500
	1000	10.0	10.2	G	313	0.8	0.50	EEEHD0J102AP	(7)	500
10	100	8.0	6.2	E	62	2.0	0.30	EEEHD1A101AP	(7)	1000
	220	8.0	10.2	F	160	1.5	0.30	EEEHD1A221AP	(7)	500
	330	8.0	10.2	F	160	1.5	0.30	EEEHD1A331AP	(7)	500
16	10	4.0	5.8	B	28	12.0	0.20	EEEHD1C100AR	(5)	2000
	22	5.0	5.8	C	39	7.2	0.20	EEEHD1C220AR	(5)	1000
	47	6.3	5.8	D	70	4.0	0.20	EEEHD1C470AP	(5)	1000
	100	8.0	10.2	F	130	1.5	0.20	EEEHD1C101AP	(7)	500
	220	10.0	10.2	G	220	0.8	0.20	EEEHD1C221AP	(7)	500
	470	10.0	10.2	G	340	0.8	0.20	EEEHD1C471AP	(7)	500
25	4.7	4.0	5.8	B	17	12.0	0.16	EEEHD1E4R7AR	(5)	2000
	10	5.0	5.8	C	28	7.2	0.16	EEEHD1E100AR	(5)	1000
	22	6.3	5.8	D	55	4.0	0.16	EEEHD1E220AP	(5)	1000
	33	6.3	5.8	D	55	4.0	0.16	EEEHD1E330AP	(5)	1000
	47	8.0	6.2	E	56	2.0	0.18	EEEHD1E470AP	(7)	1000
	100	8.0	10.2	F	130	1.5	0.16	EEEHD1E101AP	(7)	500
	330	10.0	10.2	G	238	0.8	0.16	EEEHD1E331AP	(7)	500
35	4.7	4.0	5.8	B	17	12.0	0.13	EEEHD1V4R7AR	(5)	2000
	10	5.0	5.8	C	28	7.2	0.13	EEEHD1V100AR	(5)	1000
	22	6.3	5.8	D	55	4.0	0.13	EEEHD1V220AP	(5)	1000
	33	8.0	6.2	E	53	2.0	0.16	EEEHD1V330AP	(7)	1000
		6.3	7.7	D8	57	2.0	0.13	EEEHDV330XAP	(5)	900
	47	6.3	7.7	D8	57	2.0	0.14	EEEHDV470XAP	(5)	900
		8.0	10.2	F	79	1.5	0.14	EEEHD1V470AP	(7)	500
	100	10.0	10.2	G	101	0.8	0.14	EEEHD1V101AP	(7)	500
	220	10.0	10.2	G	220	0.8	0.14	EEEHD1V221AP	(7)	500

■ 50 V to 100 V (Standard reflow)

Endurance : 105 °C 5000 h

Rated voltage (V)	Capacitance (±20 %) (μF)	Case size (mm)		Size code	Specification			Part No.	Reflow	Min. Packaging Q'ty (pcs)
		øD	L		Ripple current* ¹ (mA rms)	Impedance* ² (Ω)	tanδ* ³			Taping
50	1	4.0	5.8	B	7	12.0	0.12	EEEHD1H1R0R	(1)	2000
	2.2	4.0	5.8	B	12	12.0	0.12	EEEHD1H2R2R	(1)	2000
	3.3	4.0	5.8	B	16	12.0	0.12	EEEHD1H3R3R	(1)	2000
	4.7	5.0	5.8	C	21	7.2	0.12	EEEHD1H4R7R	(1)	1000
	10	6.3	5.8	D	33	4.0	0.12	EEEHD1H100P	(1)	1000
	22	8.0	6.2	E	50	2.0	0.14	EEEHD1H220P	(2)	1000
	33	8.0	10.2	F	74	1.5	0.14	EEEHD1H330P	(2)	500
	47	10.0	10.2	G	94	0.8	0.14	EEEHD1H470P	(2)	500
	100	10.0	10.2	G	94	0.8	0.14	EEEHD1H101P	(2)	500
63	10	8.0	6.2	E	45	2.0	0.18	EEEHD1J100P	(2)	1000
	22	8.0	10.2	F	65	1.5	0.18	EEEHD1J220P	(2)	500
	33	10.0	10.2	G	80	0.8	0.18	EEEHD1J330P	(2)	500
100	10	8.0	10.2	F	55	1.5	0.18	EEEHD2A100P	(2)	500
	22	10.0	10.2	G	70	0.8	0.18	EEEHD2A220P	(2)	500

*1: Ripple current (100 kHz / +105 °C)

*2: Impedance (100 kHz / +20 °C)

*3: tan δ (120 Hz / +20 °C)

· If Part number exceeds 12 digits, voltage code is abbreviated as follows; 0J → J, 1A → A, 1C → C, 1E → E, 1V → V

· Please refer to the page of "Reflow Profile" and "The Taping Dimensions".

· When requesting vibration-proof product, please put the last "V" instead to "P"

Surface Mount Type

Medium-size HD series V type

High temperature Lead-Free reflow (suffix : A*)



Features

- Endurance : 105 °C 5000 h
- Vibration-proof product (30G guaranteed) is available upon request
- AEC-Q200 compliant
- RoHS compliant

Specifications

Category temp. range	-55 °C to +105 °C	
Rated voltage range	6.3 V to 35 V	
Capacitance range	680 μF to 7500 μF	
Capacitance tolerance	±20 % (120 Hz / +20 °C)	
Leakage current	I ≤ 0.01 CV (μA) After 2 minutes	
Dissipation factor (tan δ)	Please see the attached characteristics list	
Endurance	After applying rated working voltage for 5000 hours at +105 °C ± 2 °C and then being stabilized at +20 °C, capacitors shall meet the following limits.	
	Capacitance change	Within ±30 % of the initial value
	Dissipation factor (tan δ)	≤ 200 % of the initial limit
	Leakage current	Within the initial limit
Shelf life	After storage for 1000 hours at +105 °C ± 2 °C with no voltage applied and then being stabilized at +20 °C, capacitors shall meet the limits specified in endurance. (With voltage treatment)	
Resistance to soldering heat	After reflow soldering and then being stabilized at +20 °C, capacitors shall meet the following limits.	
	Capacitance change	Within ±10 % of the initial value
	Dissipation factor (tan δ)	Within the initial limit
	Leakage current	Within the initial limit

Frequency correction factor for ripple current

Cap. (μF) \ Freq. (Hz)	60	120	1 k	10 k	100 k to
680 to 1000	0.93	1.00	1.20	1.27	1.33
1500 to 2200	0.94	1.00	1.13	1.19	1.25
3300 to 7500	0.94	1.00	1.12	1.18	1.18

Marking

Example : 6.3 V 3300 μF
Marking color : BLACK

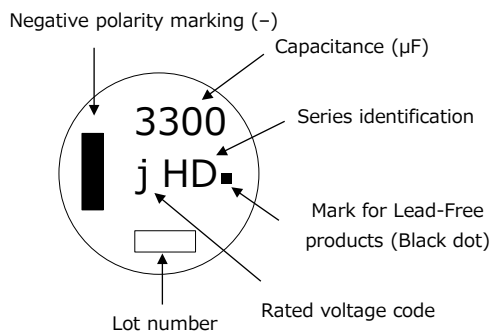

R.voltage code	Unit : V
j 6.3	E 25
A 10	V 35
C 16	

Dimensions

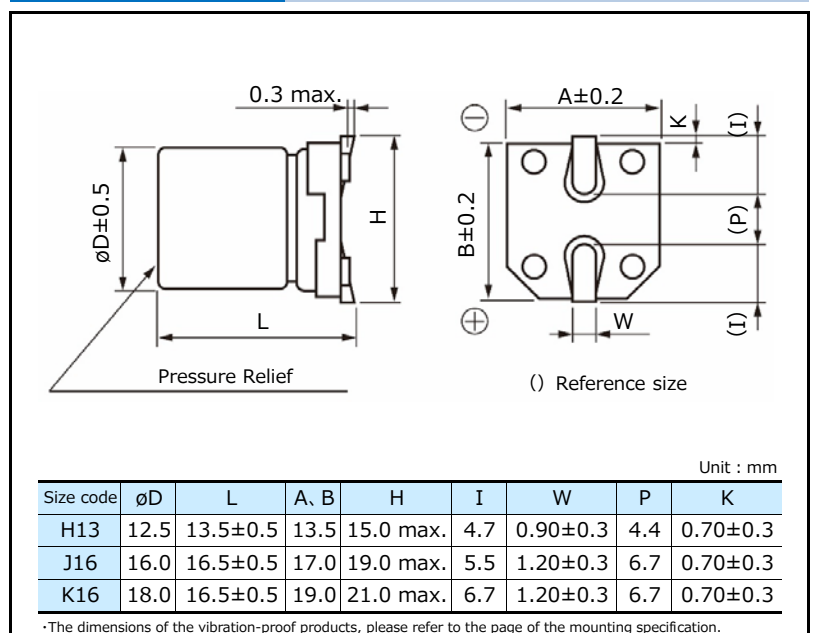

Characteristics list

Endurance : 105 °C 5000 h

Rated voltage (V)	Capacitance (±20 %) (μF)	Case size (mm)		Size code	Specification		Part No.	Reflow	Min. Packaging Q'ty (pcs)
		øD	L		Ripple current* ¹ (mA rms)	tan δ* ²			Taping
6.3	3300	12.5	13.5	H13	680	0.32	EEEHD0J332AQ	(9)	200
	6800	16.0	16.5	J16	1280	0.38	EEEHD0J682AM	(9)	125
	7500	18.0	16.5	K16	1540	0.40	EEEHD0J752AM	(9)	125
10	2200	12.5	13.5	H13	620	0.24	EEEHD1A222AQ	(9)	200
	4700	16.0	16.5	J16	1280	0.28	EEEHD1A472AM	(9)	125
	6800	18.0	16.5	K16	1540	0.32	EEEHD1A682AM	(9)	125
16	1500	12.5	13.5	H13	620	0.18	EEEHD1C152AQ	(9)	200
	3300	16.0	16.5	J16	1280	0.22	EEEHD1C332AM	(9)	125
	4700	18.0	16.5	K16	1540	0.24	EEEHD1C472AM	(9)	125
25	1000	12.5	13.5	H13	580	0.16	EEEHD1E102AQ	(9)	200
	2200	16.0	16.5	J16	1200	0.18	EEEHD1E222AM	(9)	125
	3300	18.0	16.5	K16	1540	0.20	EEEHD1E332AM	(9)	125
35	680	12.5	13.5	H13	580	0.14	EEEHD1V681AQ	(9)	200
	1500	16.0	16.5	J16	1200	0.16	EEEHD1V152AM	(9)	125
	1800	18.0	16.5	K16	1450	0.16	EEEHD1V182AM	(9)	125

*1: Ripple current (100 kHz / +105 °C)

*2: tan δ (120 Hz / +20 °C)

• Please refer to the page of "Reflow Profile" and "The Taping Dimensions".

• When requesting vibration-proof product, please put the last "V" instead to "Q" or "M"

Surface Mount Type

FC series V type

High temperature Lead-Free reflow (suffix : A*)

Low impedance

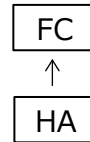

Features

- Endurance : 105 °C 1000 h
- Low impedance (1/2 for HA series)
- Vibration-proof product (30G guaranteed) is available upon request ($\phi 8 \leq$)
- AEC-Q200 compliant
- RoHS compliant

Specifications

Category temp. range	-40 °C to +105 °C					
Rated voltage range	6.3 V to 35 V					
Capacitance range	1 μ F to 1500 μ F					
Capacitance tolerance	± 20 % (120 Hz / +20°C)					
Leakage current	$I \leq 0.01$ CV or 3 (μ A) After 2 minutes (Whichever is greater)					
Dissipation factor (tan δ)	Please see the attached characteristics list					
Characteristics at low temperature	Rated voltage (V)	6.3	10	16	25	35
	Z (-25 °C) / Z (+20 °C)	2	2	2	2	2
	Z (-40 °C) / Z (+20 °C)	3	3	3	3	3
Endurance	After applying rated working voltage for 1000 hours at +105 °C \pm 2 °C and then being stabilized at +20 °C, capacitors shall meet the following limits.					
	Capacitance change	Within ± 20 % of the initial value				
	Dissipation factor (tan δ)	≤ 200 % of the initial limit				
	DC leakage current	Within the initial limit				
Shelf life	After storage for 1000 hours at +105 °C \pm 2 °C with no voltage applied and then being stabilized at +20 °C, capacitors shall meet the limits specified in endurance. (With voltage treatment)					
	After reflow soldering and then being stabilized at +20 °C, capacitors shall meet the following limits.					
Resistance to soldering heat	Capacitance change	Within ± 10 % of the initial value				
	Dissipation factor (tan δ)	Within the initial limit				
	DC leakage current	Within the initial limit				

Frequency correction factor for ripple current

Frequency (Hz)	50, 60	120	1 k	10 k ~	100 k to
Correction factor	0.70	0.75	0.90	0.95	1.00

Marking

Example : 6.3 V 22 μ F
Marking color : BLACK

Negative polarity marking (-)

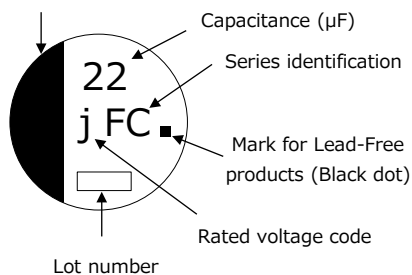

R.voltage code		Unit : V	
j	6.3	E	25
A	10	V	35
C	16		

Dimensions

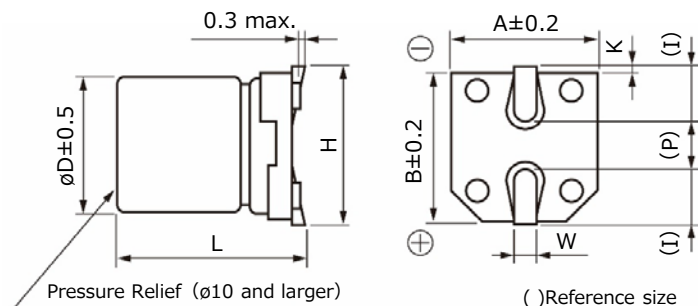

Size code	ϕD	L	A, B	H	I	W	P	K
B	4.0	5.4 ^{+0.1} _{-0.2}	4.3	5.5 max.	1.8	0.65 \pm 0.1	1.0	0.35 ^{+0.15} _{-0.20}
C	5.0	5.4 ^{+0.1} _{-0.2}	5.3	6.5 max.	2.2	0.65 \pm 0.1	1.5	0.35 ^{+0.15} _{-0.20}
D	6.3	5.4 ^{+0.1} _{-0.2}	6.6	7.8 max.	2.6	0.65 \pm 0.1	1.8	0.35 ^{+0.15} _{-0.20}
E	8.0	6.2 \pm 0.3	8.3	9.5 max.	3.4	0.65 \pm 0.1	2.2	0.35 ^{+0.15} _{-0.20}
F	8.0	10.2 \pm 0.3	8.3	10.0 max.	3.4	0.90 \pm 0.2	3.1	0.70 \pm 0.2
G	10.0	10.2 \pm 0.3	10	12.0 max.	3.5	0.90 \pm 0.2	4.6	0.70 \pm 0.2

*The dimensions of the vibration-proof products, please refer to the page of the mounting specification.

Characteristics list

Endurance : 105 °C 1000 h

Rated voltage (V)	Capacitance (±20 %) (μF)	Case size (mm)		Size code	Specification			Part No.	Reflow	Min. Packaging Q'ty (pcs)
		øD	L		Ripple current* ¹ (mA rms)	Impedance* ² (Ω)	tanδ* ³			Taping
6.3	22	4.0	5.4	B	60	3.00	0.26	EEEF0J220AR	(5)	2000
	47	5.0	5.4	C	95	1.80	0.26	EEEF0J470AR	(5)	1000
	68	6.3	5.4	D	140	1.00	0.26	EEEF0J680AP	(5)	1000
	100	6.3	5.4	D	140	1.00	0.26	EEEF0J101AP	(5)	1000
	220	8.0	6.2	E	230	0.40	0.26	EEEF0J221AP	(6)	1000
	330	8.0	10.2	F	450	0.30	0.26	EEEF0J331AP	(6)	500
	1000	10.0	10.2	G	670	0.15	0.26	EEEF0J102AP	(6)	500
	1500	10.0	10.2	G	670	0.15	0.26	EEEF0J152AP	(6)	500
10	33	5.0	5.4	C	95	1.80	0.19	EEEF1A330AR	(5)	1000
	100	8.0	6.2	E	230	0.40	0.19	EEEF1A101AP	(6)	1000
	150	8.0	6.2	E	230	0.40	0.19	EEEF1A151AP	(6)	1000
	220	8.0	10.2	F	450	0.30	0.19	EEEF1A221AP	(6)	500
	470	10.0	10.2	G	670	0.15	0.19	EEEF1A471AP	(6)	500
	1000	10.0	10.2	G	670	0.15	0.19	EEEF1A102AP	(6)	500
16	10	4.0	5.4	B	60	3.00	0.16	EEEF1C100AR	(5)	2000
	22	5.0	5.4	C	95	1.80	0.16	EEEF1C220AR	(5)	1000
	47	6.3	5.4	D	140	1.00	0.16	EEEF1C470AP	(5)	1000
	68	8.0	6.2	E	230	0.40	0.16	EEEF1C680AP	(6)	1000
	100	8.0	6.2	E	230	0.40	0.16	EEEF1C101AP	(6)	1000
	220	10.0	10.2	G	670	0.15	0.16	EEEF1C221AP	(6)	500
	330	10.0	10.2	G	670	0.15	0.16	EEEF1C331AP	(6)	500
	470	10.0	10.2	G	670	0.15	0.16	EEEF1C471AP	(6)	500
	680	10.0	10.2	G	670	0.15	0.16	EEEF1C681AP	(6)	500
25	6.8	4.0	5.4	B	60	3.00	0.14	EEEF1E6R8AR	(5)	2000
	22	6.3	5.4	D	140	1.00	0.14	EEEF1E220AP	(5)	1000
	33	6.3	5.4	D	140	1.00	0.14	EEEF1E330AP	(5)	1000
	47	8.0	6.2	E	230	0.40	0.14	EEEF1E470AP	(6)	1000
	68	8.0	10.2	F	450	0.30	0.14	EEEF1E680AP	(6)	500
	100	8.0	10.2	F	450	0.30	0.14	EEEF1E101AP	(6)	500
	220	10.0	10.2	G	670	0.15	0.14	EEEF1E221AP	(6)	500
	330	10.0	10.2	G	670	0.15	0.14	EEEF1E331AP	(6)	500
	470	10.0	10.2	G	670	0.15	0.14	EEEF1E471AP	(6)	500
35	1	4.0	5.4	B	60	3.00	0.12	EEEF1V1R0AR	(5)	2000
	2.2	4.0	5.4	B	60	3.00	0.12	EEEF1V2R2AR	(5)	2000
	3.3	4.0	5.4	B	60	3.00	0.12	EEEF1V3R3AR	(5)	2000
	4.7	4.0	5.4	B	60	3.00	0.12	EEEF1V4R7AR	(5)	2000
	6.8	5.0	5.4	C	95	1.80	0.12	EEEF1V6R8AR	(5)	1000
	10	5.0	5.4	C	95	1.80	0.12	EEEF1V100AR	(5)	1000
	22	6.3	5.4	D	140	1.00	0.12	EEEF1V220AP	(5)	1000
	33	8.0	6.2	E	230	0.40	0.12	EEEF1V330AP	(6)	1000
	47	8.0	6.2	E	230	0.40	0.12	EEEF1V470AP	(6)	1000
	100	10.0	10.2	G	670	0.15	0.12	EEEF1V101AP	(6)	500
	220	10.0	10.2	G	670	0.15	0.12	EEEF1V221AP	(6)	500
330	10.0	10.2	G	670	0.15	0.12	EEEF1V331AP	(6)	500	

*1: Ripple current (100 kHz / +105 °C)

*2: Impedance (100 kHz / +20 °C)

*3: tanδ (120 Hz / +20 °C)

• Please refer to the page of "Reflow Profile" and "The Taping Dimensions".

• When requesting vibration-proof product, please put the last "V" instead to "P"

Surface Mount Type

FC series

V type

Low impedance



Features

- Endurance : 105 °C 1000 h
- Low impedance (1/2 for HA series)
- Vibration-proof product (30G guaranteed) is available upon request ($\phi 8 \leq$)
- AEC-Q200 compliant
- RoHS compliant

Specifications

Category temp. range	-40 °C to +105 °C							
Rated voltage range	6.3 V to 50 V							
Capacitance range	1 μ F to 1500 μ F							
Capacitance tolerance	± 20 % (120 Hz / +20°C)							
Leakage current	$I \leq 0.01$ CV or 3 (μ A) After 2 minutes (Whichever is greater)							
Dissipation factor (tan δ)	Please see the attached characteristics list							
Characteristics at low temperature	Rated voltage (V)	6.3	10	16	25	35	50	(Impedance ratio at 120 Hz)
	Z (-25 °C) / Z (+20 °C)	2	2	2	2	2	2	
	Z (-40 °C) / Z (+20 °C)	3	3	3	3	3	3	
Endurance	After applying rated working voltage for 1000 hours at +105 °C \pm 2 °C and then being stabilized at +20 °C, capacitors shall meet the following limits.							
	Capacitance change	Within ± 20 % of the initial value						
	Dissipation factor (tan δ)	≤ 200 % of the initial limit						
	DC leakage current	Within the initial limit						
Shelf life	After storage for 1000 hours at +105 °C \pm 2 °C with no voltage applied and then being stabilized at +20 °C, capacitors shall meet the limits specified in endurance. (With voltage treatment)							
Resistance to soldering heat	After reflow soldering and then being stabilized at +20 °C, capacitors shall meet the following limits.							
	Capacitance change	Within ± 10 % of the initial value						
	Dissipation factor (tan δ)	Within the initial limit						
	DC leakage current	Within the initial limit						

Frequency correction factor for ripple current

Frequency (Hz)	50, 60	120	1 k	10 k ~	100 k to
Correction factor	0.70	0.75	0.90	0.95	1.00

Marking

Example : 6.3 V 22 μ F
Marking color : BLACK

Negative polarity marking (-)

Capacitance (μ F)

Series identification

Mark for Lead-Free products (Black dot)

Rated voltage code

Lot number

R.voltage code		Unit : V	
j	6.3	E	25
A	10	V	35
C	16	H	50

Dimensions

Pressure Relief ($\phi 10$ and larger)

() Reference size

Size code	ϕD	L	A, B	H	I	W	P	K
B	4.0	5.4 $^{+0.1}_{-0.2}$	4.3	5.5 max.	1.8	0.65 \pm 0.1	1.0	0.35 $^{+0.15}_{-0.20}$
C	5.0	5.4 $^{+0.1}_{-0.2}$	5.3	6.5 max.	2.2	0.65 \pm 0.1	1.5	0.35 $^{+0.15}_{-0.20}$
D	6.3	5.4 $^{+0.1}_{-0.2}$	6.6	7.8 max.	2.6	0.65 \pm 0.1	1.8	0.35 $^{+0.15}_{-0.20}$
E	8.0	6.2 \pm 0.3	8.3	9.5 max.	3.4	0.65 \pm 0.1	2.2	0.35 $^{+0.15}_{-0.20}$
F	8.0	10.2 \pm 0.3	8.3	10.0 max.	3.4	0.90 \pm 0.2	3.1	0.70 \pm 0.2
G	10.0	10.2 \pm 0.3	10	12.0 max.	3.5	0.90 \pm 0.2	4.6	0.70 \pm 0.2

Unit : mm

*The dimensions of the vibration-proof products, please refer to the page of the mounting specification.

Characteristics list

Rated voltage (V)	Capacitance (±20 %) (μF)	Case size (mm)		Size code	Specification			Part No.	Reflow	Min. Packaging Q'ty (pcs)
		øD	L		Ripple current* ¹ (mA rms)	Impedance* ² (Ω)	tanδ* ³			Taping
6.3	22	4.0	5.4	B	60	3.00	0.26	EEEF0J220R	(1)	2000
	47	5.0	5.4	C	95	1.80	0.26	EEEF0J470R	(1)	1000
	68	6.3	5.4	D	140	1.00	0.26	EEEF0J680P	(1)	1000
	100	6.3	5.4	D	140	1.00	0.26	EEEF0J101P	(1)	1000
	220	8.0	6.2	E	230	0.40	0.26	EEEF0J221P	(2)	1000
	330	8.0	10.2	F	450	0.30	0.26	EEEF0J331P	(2)	500
	1000	10.0	10.2	G	670	0.15	0.26	EEEF0J102P	(2)	500
	1500	10.0	10.2	G	670	0.15	0.26	EEEF0J152P	(2)	500
10	33	5.0	5.4	C	95	1.80	0.19	EEEF1A330R	(1)	1000
	100	8.0	6.2	E	230	0.40	0.19	EEEF1A101P	(2)	1000
	150	8.0	6.2	E	230	0.40	0.19	EEEF1A151P	(2)	1000
	220	8.0	10.2	F	450	0.30	0.19	EEEF1A221P	(2)	500
	470	10.0	10.2	G	670	0.15	0.19	EEEF1A471P	(2)	500
	1000	10.0	10.2	G	670	0.15	0.19	EEEF1A102P	(2)	500
16	10	4.0	5.4	B	60	3.00	0.16	EEEF1C100R	(1)	2000
	22	5.0	5.4	C	95	1.80	0.16	EEEF1C220R	(1)	1000
	47	6.3	5.4	D	140	1.00	0.16	EEEF1C470P	(1)	1000
	68	8.0	6.2	E	230	0.40	0.16	EEEF1C680P	(2)	1000
	100	8.0	6.2	E	230	0.40	0.16	EEEF1C101P	(2)	1000
	220	10.0	10.2	G	670	0.15	0.16	EEEF1C221P	(2)	500
	330	10.0	10.2	G	670	0.15	0.16	EEEF1C331P	(2)	500
	470	10.0	10.2	G	670	0.15	0.16	EEEF1C471P	(2)	500
25	6.8	4.0	5.4	B	60	3.00	0.14	EEEF1E6R8R	(1)	2000
	22	6.3	5.4	D	140	1.00	0.14	EEEF1E220P	(1)	1000
	33	6.3	5.4	D	140	1.00	0.14	EEEF1E330P	(1)	1000
	47	8.0	6.2	E	230	0.40	0.14	EEEF1E470P	(2)	1000
	68	8.0	10.2	F	450	0.30	0.14	EEEF1E680P	(2)	500
	100	8.0	10.2	F	450	0.30	0.14	EEEF1E101P	(2)	500
	220	10.0	10.2	G	670	0.15	0.14	EEEF1E221P	(2)	500
	330	10.0	10.2	G	670	0.15	0.14	EEEF1E331P	(2)	500
470	10.0	10.2	G	670	0.15	0.14	EEEF1E471P	(2)	500	
35	1	4.0	5.4	B	60	3.00	0.12	EEEF1V1R0R	(1)	2000
	2.2	4.0	5.4	B	60	3.00	0.12	EEEF1V2R2R	(1)	2000
	3.3	4.0	5.4	B	60	3.00	0.12	EEEF1V3R3R	(1)	2000
	4.7	4.0	5.4	B	60	3.00	0.12	EEEF1V4R7R	(1)	2000
	6.8	5.0	5.4	C	95	1.80	0.12	EEEF1V6R8R	(1)	1000
	10	5.0	5.4	C	95	1.80	0.12	EEEF1V100R	(1)	1000
	22	6.3	5.4	D	140	1.00	0.12	EEEF1V220P	(1)	1000
	33	8.0	6.2	E	230	0.40	0.12	EEEF1V330P	(2)	1000
	47	8.0	6.2	E	230	0.40	0.12	EEEF1V470P	(2)	1000
	100	10.0	10.2	G	670	0.15	0.12	EEEF1V101P	(2)	500
	220	10.0	10.2	G	670	0.15	0.12	EEEF1V221P	(2)	500
330	10.0	10.2	G	670	0.15	0.12	EEEF1V331P	(2)	500	
50	1	4.0	5.4	B	30	5.00	0.12	EEEF1H1R0R	(1)	2000
	2.2	4.0	5.4	B	30	5.00	0.12	EEEF1H2R2R	(1)	2000
	3.3	4.0	5.4	B	30	5.00	0.12	EEEF1H3R3R	(1)	2000
	4.7	5.0	5.4	C	50	3.00	0.12	EEEF1H4R7R	(1)	1000
	10	6.3	5.4	D	70	2.00	0.12	EEEF1H100P	(1)	1000
	22	8.0	6.2	E	120	0.70	0.12	EEEF1H220P	(2)	1000
	33	8.0	10.2	F	300	0.60	0.12	EEEF1H330P	(2)	500
	47	10.0	10.2	G	500	0.30	0.12	EEEF1H470P	(2)	500
	100	10.0	10.2	G	500	0.30	0.12	EEEF1H101P	(2)	500
220	10	10.2	G	500	0.30	0.12	EEEF1H221P	(2)	500	

*1: Ripple current (100 kHz / +105 °C)

*2: Impedance (100 kHz / +20 °C)

*3: tanδ (120 Hz / +20 °C)

• Please refer to the page of "Reflow Profile" and "The Taping Dimensions".

• When requesting vibration-proof product, please put the last "V" instead to "P"

Surface Mount Type

FK series **V** type

High temperature Lead-Free reflow (suffix : A*)



Features

- Endurance : 105 °C 2000 h
- Low impedance (40 % to 60 % less than FC series)
- Miniaturized (30 % to 50 % less than FC series)
- Vibration-proof product (30G guaranteed) is available upon request (ø6.3 ≤)
- AEC-Q200 compliant
- RoHS compliant

Specifications

Category temp. range	-55 °C to +105 °C					
Rated voltage range	6.3 V to 35 V					
Capacitance range	4.7 μF to 1500 μF					
Capacitance tolerance	±20 % (120 Hz / +20 °C)					
Leakage current	I ≤ 0.01 CV or 3 (μA) After 2 minutes (Whichever is greater)					
Dissipation factor (tan δ)	Please see the attached characteristics list					
Characteristics at low temperature	Rated voltage (V)	6.3	10	16	25	35
	Z (-25 °C) / Z (+20 °C)	2	2	2	2	2
	Z (-40 °C) / Z (+20 °C)	3	3	3	3	3
	Z (-55 °C) / Z (+20 °C)	4	4	4	3	3
(Impedance ratio at 120 Hz)						
Endurance	After applying rated working voltage for 2000 hours at +105 °C ± 2 °C and then being stabilized at +20 °C, capacitors shall meet the following limits.					
	Capacitance change	Within ±30 % of the initial value				
	Dissipation factor (tan δ)	≤ 200 % of the initial limit				
	Leakage current	Within the initial limit				
Shelf life	After storage for 1000 hours at +105 °C ± 2 °C with no voltage applied and then being stabilized at +20 °C, capacitors shall meet the limits specified in endurance. (With voltage treatment)					
Resistance to soldering heat	After reflow soldering and then being stabilized at +20 °C, capacitors shall meet the following limits.					
	Capacitance change	Within ±10 % of the initial value				
	Dissipation factor (tan δ)	Within the initial limit				
	Leakage current	Within the initial limit				

Frequency correction factor for ripple current

Cap. (μF) \ Freq. (Hz)	120	1 k	10 k	100 k to
4.7 to 470	0.65	0.85	0.95	1.00
680 to 1500	0.70	0.90	0.95	1.00

Marking

Example : 6.3 V 22 μF
Marking color : BLACK

Negative polarity marking (-)

Capacitance (μF)

Series identification

Mark for Lead-Free products (Black dot)

Rated voltage code

Lot number

R. voltage code		Unit : V	
j	6.3	E	25
A	10	V	35
C	16		

Dimensions

Pressure Relief (ø10 and larger)

(I) Reference size

Size code	øD	L	A, B	H	I	W	P	K
B	4.0	5.8±0.3	4.3	5.5 max.	1.8	0.65±0.1	1.0	0.35 ^{+0.15} _{-0.20}
C	5.0	5.8±0.3	5.3	6.5 max.	2.2	0.65±0.1	1.5	0.35 ^{+0.15} _{-0.20}
D	6.3	5.8±0.3	6.6	7.8 max.	2.6	0.65±0.1	1.8	0.35 ^{+0.15} _{-0.20}
D8	6.3	7.7±0.3	6.6	7.8 max.	2.6	0.65±0.1	1.8	0.35 ^{+0.15} _{-0.20}
E	8.0	6.2±0.3	8.3	9.5 max.	3.4	0.65±0.1	2.2	0.35 ^{+0.15} _{-0.20}
F	8.0	10.2±0.3	8.3	10.0 max.	3.4	0.90±0.2	3.1	0.70±0.2
G	10.0	10.2±0.3	10.3	12.0 max.	3.5	0.90±0.2	4.6	0.70±0.2

Unit : mm

*The dimensions of the vibration-proof products, please refer to the page of the mounting specification.

Characteristics list

Endurance : 105 °C 2000 h

Rated voltage (V)	Capacitance (±20 %) (µF)	Case size (mm)			Size code*1	Specification			Part No.		Reflow	Min. Packaging Q'ty (pcs)
		øD	L			Ripple current*2 (mA rms)	Impe-dance*3 (Ω)	tan δ*4	Standard Product	Vibration-proof product		Taping
			Standard	Vibration -proof								
6.3	22	4.0	5.8	—	B	90	1.35	0.26	EEEFK0J220AR	—	(5)	2000
	47	4.0	5.8	—	(B)	90	1.35	0.26	EEEFKJ470UAR	—	(5)	2000
		5.0	5.8	—	C	160	0.70	0.26	EEEFK0J470AR	—	(5)	1000
	100	5.0	5.8	—	(C)	160	0.70	0.26	EEEFKJ101UAR	—	(5)	1000
		6.3	5.8	6.1	D	240	0.36	0.26	EEEFK0J101AP	EEEFK0J101AV	(5)	1000
	220	6.3	5.8	6.1	D	240	0.36	0.26	EEEFK0J221AP	EEEFK0J221AV	(5)	1000
	330	6.3	7.7	8.0	D8	280	0.34	0.26	EEEFKJ331XAP	EEEFKJ331XAV	(5)	900
		8.0	6.2	6.5	E	300	0.26	0.26	EEEFK0J331AP	EEEFK0J331AV	(6)	1000
	470	8.0	10.2	10.5	F	600	0.16	0.26	EEEFK0J471AP	EEEFK0J471AV	(6)	500
	1000	8.0	10.2	10.5	F	600	0.16	0.26	EEEFK0J102AP	EEEFK0J102AV	(6)	500
1500	10.0	10.2	10.5	G	850	0.08	0.26	EEEFK0J152AP	EEEFK0J152AV	(6)	500	
10	22	4.0	5.8	—	B	90	1.35	0.19	EEEFK1A220AR	—	(5)	2000
	33	4.0	5.8	—	(B)	90	1.35	0.19	EEEFKA330UAR	—	(5)	2000
		5.0	5.8	—	C	160	0.70	0.19	EEEFK1A330AR	—	(5)	1000
	150	6.3	5.8	6.1	D	240	0.36	0.19	EEEFK1A151AP	EEEFK1A151AV	(5)	1000
	220	6.3	7.7	8.0	D8	280	0.34	0.19	EEEFKA221XAP	EEEFKA221XAV	(5)	900
		8.0	6.2	6.5	E	300	0.26	0.19	EEEFK1A221AP	EEEFK1A221AV	(6)	1000
	330	8.0	10.2	10.5	F	600	0.16	0.19	EEEFK1A331AP	EEEFK1A331AV	(6)	500
	470	8.0	10.2	10.5	F	600	0.16	0.19	EEEFK1A471AP	EEEFK1A471AV	(6)	500
	680	8.0	10.2	10.5	F	600	0.16	0.19	EEEFK1A681AP	EEEFK1A681AV	(6)	500
	1000	10.0	10.2	10.5	G	850	0.08	0.19	EEEFK1A102AP	EEEFK1A102AV	(6)	500
16	10	4.0	5.8	—	B	90	1.35	0.16	EEEFK1C100AR	—	(5)	2000
	22	4.0	5.8	—	(B)	90	1.35	0.16	EEEFKC220UAR	—	(5)	2000
		5.0	5.8	—	C	160	0.70	0.16	EEEFK1C220AR	—	(5)	1000
	47	5.0	5.8	—	(C)	160	0.70	0.16	EEEFKC470UAR	—	(5)	1000
	68	6.3	5.8	6.1	D	240	0.36	0.16	EEEFK1C470AP	EEEFK1C470AV	(5)	1000
		6.3	5.8	6.1	D	240	0.36	0.16	EEEFK1C680AP	EEEFK1C680AV	(5)	1000
	100	6.3	5.8	6.1	D	240	0.36	0.16	EEEFK1C101AP	EEEFK1C101AV	(5)	1000
	150	6.3	7.7	8.0	D8	280	0.34	0.16	EEEFKC151XAP	EEEFKC151XAV	(5)	900
		6.3	7.7	8.0	D8	280	0.34	0.16	EEEFKC221XAP	EEEFKC221XAV	(5)	900
	220	8.0	6.2	6.5	E	300	0.26	0.16	EEEFK1C221AP	EEEFK1C221AV	(6)	1000
25	330	8.0	10.2	10.5	F	600	0.16	0.16	EEEFK1C331AP	EEEFK1C331AV	(6)	500
	470	8.0	10.2	10.5	F	600	0.16	0.16	EEEFK1C471AP	EEEFK1C471AV	(6)	500
	680	10.0	10.2	10.5	G	850	0.08	0.16	EEEFK1C681AP	EEEFK1C681AV	(6)	500
	10	4.0	5.8	—	B	90	1.35	0.14	EEEFK1E100AR	—	(5)	2000
	22	5.0	5.8	—	C	160	0.70	0.14	EEEFK1E220AR	—	(5)	1000
		5.0	5.8	—	(C)	160	0.70	0.14	EEEFKE330UAR	—	(5)	1000
	33	6.3	5.8	6.1	D	240	0.36	0.14	EEEFK1E330AP	EEEFK1E330AV	(5)	1000
	47	6.3	5.8	6.1	D	240	0.36	0.14	EEEFK1E470AP	EEEFK1E470AV	(5)	1000
	68	6.3	5.8	6.1	D	240	0.36	0.14	EEEFK1E680AP	EEEFK1E680AV	(5)	1000
	100	6.3	7.7	8.0	D8	280	0.34	0.14	EEEFKE101XAP	EEEFKE101XAV	(5)	900
8.0		6.2	6.5	E	300	0.26	0.14	EEEFK1E101AP	EEEFK1E101AV	(6)	1000	
150	8.0	10.2	10.5	F	600	0.16	0.14	EEEFK1E151AP	EEEFK1E151AV	(6)	500	
220	8.0	10.2	10.5	F	600	0.16	0.14	EEEFK1E221AP	EEEFK1E221AV	(6)	500	
330	8.0	10.2	10.5	F	600	0.16	0.14	EEEFK1E331AP	EEEFK1E331AV	(6)	500	
470	10.0	10.2	10.5	G	850	0.08	0.14	EEEFK1E471AP	EEEFK1E471AV	(6)	500	
35	4.7	4.0	5.8	—	B	90	1.35	0.12	EEEFK1V4R7AR	—	(5)	2000
	10	4.0	5.8	—	(B)	90	1.35	0.12	EEEFKV100UAR	—	(5)	2000
		5.0	5.8	—	C	160	0.70	0.12	EEEFK1V100AR	—	(5)	1000
	22	5.0	5.8	—	C	160	0.70	0.12	EEEFK1V220AR	—	(5)	1000
	33	6.3	5.8	6.1	D	240	0.36	0.12	EEEFK1V330AP	EEEFK1V330AV	(5)	1000
	47	6.3	5.8	6.1	D	240	0.36	0.12	EEEFK1V470AP	EEEFK1V470AV	(5)	1000
	68	6.3	7.7	8.0	D8	280	0.34	0.12	EEEFKV680XAP	EEEFKV680XAV	(5)	900
	100	6.3	7.7	8.0	D8	280	0.34	0.12	EEEFKV101XAP	EEEFKV101XAV	(5)	900
		8.0	10.2	10.5	F	600	0.16	0.12	EEEFK1V101AP	EEEFK1V101AV	(6)	500
	150	8.0	10.2	10.5	F	600	0.16	0.12	EEEFK1V151AP	EEEFK1V151AV	(6)	500
220	8.0	10.2	10.5	F	600	0.16	0.12	EEEFK1V221AP	EEEFK1V221AV	(6)	500	
330	10.0	10.2	10.5	G	850	0.08	0.12	EEEFK1V331AP	EEEFK1V331AV	(6)	500	

*1: Size code (): Miniaturization product

*2: Ripple current (100 kHz / +105 °C)

*3: Impedance (100 kHz / +20 °C)

*4: tan δ (120 Hz / +20 °C)

• If Part number exceeds 12 digits, voltage code is abbreviated as follows; 0J → J, 1A → A, 1C → C, 1E → E, 1V → V

• Please refer to the page of "Reflow Profile" and "The Taping Dimensions".

Surface Mount Type

Medium-size FK series V type

High temperature Lead-Free reflow (suffix : A*)



Features

- Endurance : 105 °C 5000 h
- Vibration-proof product (30G guaranteed) is available upon request
- AEC-Q200 compliant
- RoHS compliant

Specifications

Category temp. range	-55 °C to +105 °C										
Rated voltage range	6.3 V to 100 V										
Capacitance range	47 μF to 6800 μF										
Capacitance tolerance	±20 % (120 Hz / +20 °C)										
Leakage current	I ≤ 0.01 CV (μA) After 2 minutes										
Dissipation factor (tan δ)	Please see the attached characteristics list										
Characteristics at low temperature	Rated voltage (V)	6.3	10	16	25	35	50	63	80	100	(Impedance ratio at 120 Hz)
	Z (-25 °C) / Z (+20 °C)	2	2	2	2	2	2	2	2	2	
	Z (-40 °C) / Z (+20 °C)	3	3	3	3	3	3	3	3	3	
	Z (-55 °C) / Z (+20 °C)	4	4	4	3	3	3	3	3	3	
Endurance	After applying rated working voltage for 5000 hours at +105 °C ± 2 °C and then being stabilized at +20 °C, capacitors shall meet the following limits.										
	Capacitance change	Within ±30 % of the initial value									
	Dissipation factor (tan δ)	≤ 200 % of the initial limit									
	Leakage current	Within the initial limit									
Shelf life	After storage for 1000 hours at +105 °C ± 2 °C with no voltage applied and then being stabilized at +20 °C, capacitors shall meet the limits specified in endurance. (With voltage treatment)										
Resistance to soldering heat	After reflow soldering and then being stabilized at +20 °C, capacitors shall meet the following limits.										
	Capacitance change	Within ±10 % of the initial value									
	Dissipation factor (tan δ)	Within the initial limit									
	Leakage current	Within the initial limit									

Frequency correction factor for ripple current

Frequency (Hz)	120	1 k	10 k	100 k to
Correction factor	0.75	0.90	0.95	1.00

Marking

Example : 6.3 V 3300 μF
Marking color : BLACK

Negative polarity marking (-)

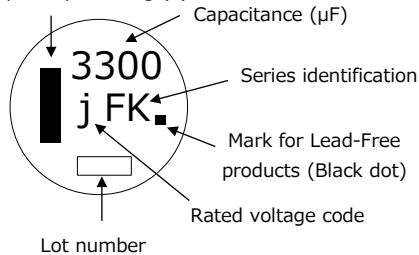

R. voltage code		Unit : V	
j	6.3	H	50
A	10	J	63
C	16	K	80
E	25	2A	100
V	35		

Dimensions

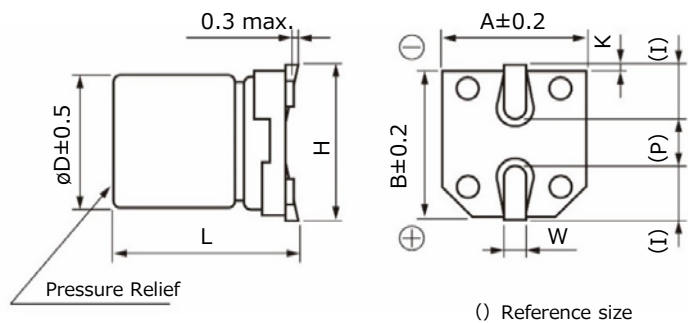

Size code	øD	L	A, B	H	I	W	P	K
H13	12.5	13.5±0.5	13.5	15.0 max.	4.7	0.90±0.3	4.4	0.70±0.3
J16	16.0	16.5±0.5	17.0	19.0 max.	5.5	1.20±0.3	6.7	0.70±0.3
K16	18.0	16.5±0.5	19.0	21.0 max.	6.7	1.20±0.3	6.7	0.70±0.3

*The dimensions of the vibration-proof products, please refer to the page of the mounting specification.

Characteristics list

Endurance : 105 °C 5000 h

Rated voltage (V)	Capacitance (±20 %) (µF)	Case size (mm)			Size code*1	Specification			Part No.		Reflow	Min. Packaging Q'ty (pcs)
		øD	L			Ripple current*2 (mA rms)	Impe-dance*3 (Ω)	tan δ*4	Standard Product	Vibration-proof product		Taping
			Standard	Vibration-proof								
6.3	3300	12.5	13.5	13.8	H13	1100	0.06	0.30	EEEFK0J332AQ	EEEFK0J332AV	(9)	200
	6800	16.0	16.5	16.8	J16	1800	0.035	0.36	EEEFK0J682AM	EEEFK0J682AV	(9)	125
10	2200	12.5	13.5	13.8	H13	1100	0.06	0.21	EEEFK1A222AQ	EEEFK1A222AV	(9)	200
	4700	16.0	16.5	16.8	J16	1800	0.035	0.25	EEEFK1A472AM	EEEFK1A472AV	(9)	125
	6800	18.0	16.5	16.8	K16	2060	0.033	0.29	EEEFK1A682AM	EEEFK1A682AV	(9)	125
16	1500	12.5	13.5	13.8	H13	1100	0.06	0.16	EEEFK1C152AQ	EEEFK1C152AV	(9)	200
	3300	16.0	16.5	16.8	J16	1800	0.035	0.20	EEEFK1C332AM	EEEFK1C332AV	(9)	125
	4700	18.0	16.5	16.8	K16	2060	0.033	0.22	EEEFK1C472AM	EEEFK1C472AV	(9)	125
25	1000	12.5	13.5	13.8	H13	1100	0.06	0.14	EEEFK1E102AQ	EEEFK1E102AV	(9)	200
	1500	16.0	16.5	16.8	J16	1800	0.035	0.16	EEEFK1E152AM	EEEFK1E152AV	(9)	125
	2200	16.0	16.5	16.8	J16	1800	0.035	0.16	EEEFK1E222AM	EEEFK1E222AV	(9)	125
	3300	18.0	16.5	16.8	K16	2060	0.033	0.18	EEEFK1E332AM	EEEFK1E332AV	(9)	125
35	470	12.5	13.5	13.8	H13	1100	0.06	0.12	EEEFK1V471AQ	EEEFK1V471AV	(9)	200
	680	12.5	13.5	13.8	H13	1100	0.06	0.12	EEEFK1V681AQ	EEEFK1V681AV	(9)	200
	1000	16.0	16.5	16.8	J16	1800	0.035	0.12	EEEFK1V102AM	EEEFK1V102AV	(9)	125
	1500	16.0	16.5	16.8	J16	1800	0.035	0.12	EEEFK1V152AM	EEEFK1V152AV	(9)	125
50	330	12.5	13.5	13.8	H13	900	0.12	0.12	EEEFK1H331AQ	EEEFK1H331AV	(10)	200
	390	12.5	13.5	13.8	H13	900	0.12	0.12	EEEFK1H391AQ	EEEFK1H391AV	(10)	200
	470	16.0	16.5	16.8	J16	1610	0.073	0.12	EEEFK1H471AM	EEEFK1H471AV	(10)	125
	560	16.0	16.5	16.8	J16	1610	0.073	0.12	EEEFK1H561AM	EEEFK1H561AV	(10)	125
	680	16.0	16.5	16.8	J16	1610	0.073	0.12	EEEFK1H681AM	EEEFK1H681AV	(10)	125
	1000	16.0	16.5	16.8	J16	1610	0.073	0.12	EEEFK1H102AM	EEEFK1H102AV	(10)	125
63	150	12.5	13.5	13.8	H13	800	0.16	0.10	EEEFK1J151AQ	EEEFK1J151AV	(10)	200
	220	12.5	13.5	13.8	H13	800	0.16	0.10	EEEFK1J221AQ	EEEFK1J221AV	(10)	200
	470	16.0	16.5	16.8	J16	1410	0.082	0.10	EEEFK1J471AM	EEEFK1J471AV	(10)	125
	680	18.0	16.5	16.8	K16	1690	0.08	0.10	EEEFK1J681AM	EEEFK1J681AV	(10)	125
80	68	12.5	13.5	13.8	H13	500	0.32	0.08	EEEFK1K680AQ	EEEFK1K680AV	(11)	200
	100	12.5	13.5	13.8	H13	500	0.32	0.08	EEEFK1K101AQ	EEEFK1K101AV	(11)	200
	150	12.5	13.5	13.8	H13	500	0.32	0.08	EEEFK1K151AQ	EEEFK1K151AV	(11)	200
	330	16.0	16.5	16.8	J16	793	0.17	0.08	EEEFK1K331AM	EEEFK1K331AV	(11)	125
	470	18.0	16.5	16.8	K16	917	0.153	0.08	EEEFK1K471AM	EEEFK1K471AV	(11)	125
100	47	12.5	13.5	13.8	H13	500	0.32	0.07	EEEFK2A470AQ	EEEFK2A470AV	(11)	200
	68	12.5	13.5	13.8	H13	500	0.32	0.07	EEEFK2A680AQ	EEEFK2A680AV	(11)	200
	100	16.0	16.5	16.8	J16	793	0.17	0.07	EEEFK2A101AM	EEEFK2A101AV	(11)	125
	150	16.0	16.5	16.8	J16	793	0.17	0.07	EEEFK2A151AM	EEEFK2A151AV	(11)	125
	220	18.0	16.5	16.8	K16	917	0.153	0.07	EEEFK2A221AM	EEEFK2A221AV	(11)	125
	330	18.0	16.5	16.8	K16	917	0.153	0.07	EEEFK2A331AM	EEEFK2A331AV	(11)	125

*1: Ripple current (100 kHz / +105 °C)

*2: Impedance (100 kHz / +20 °C)

*3: tan δ (120 Hz / +20 °C)

• Please refer to the page of "Reflow Profile" and "The Taping Dimensions".

Surface Mount Type

Halogen-free FK series V type

High temperature Lead-Free reflow (suffix : A*)



Features

- Endurance : 105 °C 2000 h
- Low impedance (40 % to 60 % less than FC series)
- Miniaturized (30 % to 50 % less than FC series)
- AEC-Q200 compliant
- RoHS compliant

Country of origin

- Malaysia

Specifications

Category temp. range	-55 °C to +105 °C						
Rated voltage range	6.3 V to 35 V						
Capacitance range	33 μF to 1500 μF						
Capacitance tolerance	±20 % (120 Hz / +20 °C)						
Leakage current	I ≤ 0.01 CV or 3 (μA) After 2 minutes (Whichever is greater)						
Dissipation factor (tan δ)	Please see the attached characteristics list						
Characteristics at low temperature	Rated voltage (V)	6.3	10	16	25	35	(Impedance ratio at 120 Hz)
	Z (-25 °C) / Z (+20 °C)	2	2	2	2	2	
	Z (-40 °C) / Z (+20 °C)	3	3	3	3	3	
	Z (-55 °C) / Z (+20 °C)	4	4	4	3	3	
Endurance	After applying rated working voltage for 2000 hours at +105 °C ± 2 °C and then being stabilized at +20 °C, capacitors shall meet the following limits.						
	Capacitance change	Within ±30 % of the initial value					
	Dissipation factor (tan δ)	≤ 200 % of the initial limit					
	Leakage current	Within the initial limit					
Shelf life	After storage for 1000 hours at +105 °C ± 2 °C with no voltage applied and then being stabilized at +20 °C, capacitors shall meet the limits specified in endurance. (With voltage treatment)						
Resistance to soldering heat	After reflow soldering and then being stabilized at +20 °C, capacitors shall meet the following limits.						
	Capacitance change	Within ±10 % of the initial value					
	Dissipation factor (tan δ)	Within the initial limit					
	Leakage current	Within the initial limit					

Frequency correction factor for ripple current

Cap. (μF)	120	1 k	10 k	100 k to
33 to 470	0.65	0.85	0.95	1.00
680 to 1500	0.70	0.90	0.95	1.00

Marking

Example : 6.3 V 100 μF
Marking color : BLACK

Negative polarity marking (-)

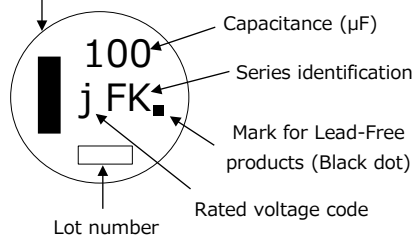

R. voltage code		Unit : V	
j	6.3	E	25
A	10	V	35
C	16		

Dimensions

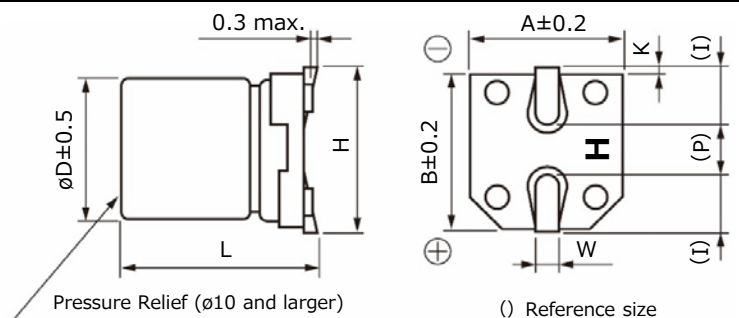

Size code	øD	L	A, B	H	I	W	P	K
D	6.3	5.8±0.3	6.6	7.8 max.	2.6	0.65±0.1	1.8	0.35 ^{+0.15} _{-0.20}
D8	6.3	7.7±0.3	6.6	7.8 max.	2.6	0.65±0.1	1.8	0.35 ^{+0.15} _{-0.20}
E	8.0	6.2±0.3	8.3	9.5 max.	3.4	0.65±0.1	2.2	0.35 ^{+0.15} _{-0.20}
F	8.0	10.2±0.3	8.3	10.0 max.	3.4	0.90±0.2	3.1	0.70±0.2
G	10.0	10.2±0.3	10.3	12.0 max.	3.5	0.90±0.2	4.6	0.70±0.2

Characteristics list

Endurance : 105 °C 2000 h

Rated voltage (V)	Capacitance (±20 %) (μF)	Case size (mm)		Size code	Specification			Part number	Reflow	Min. Packaging Q'ty (pcs)
		øD	L		Ripple current* ¹ (mA rms)	Impedance* ² (Ω)	tanδ* ³			Taping
6.3	100	6.3	5.8	D	240	0.36	0.26	EEEFK0J101AL	(5)	1000
	220	6.3	5.8	D	240	0.36	0.26	EEEFK0J221AL	(5)	1000
	330	6.3	7.7	D8	280	0.34	0.26	EEEFKJ331XAL	(5)	900
		8.0	6.2	E	300	0.26	0.26	EEEFK0J331AL	(6)	1000
	470	8.0	10.2	F	600	0.16	0.26	EEEFK0J471AL	(6)	500
	1000	8.0	10.2	F	600	0.16	0.26	EEEFK0J102AL	(6)	500
	1500	10.0	10.2	G	850	0.08	0.26	EEEFK0J152AL	(6)	500
10	150	6.3	5.8	D	240	0.36	0.19	EEEFK1A151AL	(5)	1000
	220	6.3	7.7	D8	280	0.34	0.19	EEEFKA221XAL	(5)	900
		8.0	6.2	E	300	0.26	0.19	EEEFK1A221AL	(6)	1000
	330	8.0	10.2	F	600	0.16	0.19	EEEFK1A331AL	(6)	500
	470	8.0	10.2	F	600	0.16	0.19	EEEFK1A471AL	(6)	500
	680	8.0	10.2	F	600	0.16	0.19	EEEFK1A681AL	(6)	500
	1000	10.0	10.2	G	850	0.08	0.19	EEEFK1A102AL	(6)	500
16	47	6.3	5.8	D	240	0.36	0.16	EEEFK1C470AL	(5)	1000
	68	6.3	5.8	D	240	0.36	0.16	EEEFK1C680AL	(5)	1000
	100	6.3	5.8	D	240	0.36	0.16	EEEFK1C101AL	(5)	1000
	150	6.3	7.7	D8	280	0.34	0.16	EEEFKC151XAL	(5)	900
		6.3	7.7	D8	280	0.34	0.16	EEEFKC221XAL	(5)	900
	220	8.0	6.2	E	300	0.26	0.16	EEEFK1C221AL	(6)	1000
		8.0	10.2	F	600	0.16	0.16	EEEFK1C331AL	(6)	500
	470	8.0	10.2	F	600	0.16	0.16	EEEFK1C471AL	(6)	500
	680	10.0	10.2	G	850	0.08	0.16	EEEFK1C681AL	(6)	500
25	33	6.3	5.8	D	240	0.36	0.14	EEEFK1E330AL	(5)	1000
	47	6.3	5.8	D	240	0.36	0.14	EEEFK1E470AL	(5)	1000
	68	6.3	5.8	D	240	0.36	0.14	EEEFK1E680AL	(5)	1000
	100	6.3	7.7	D8	280	0.34	0.14	EEEFKE101XAL	(5)	900
		8.0	6.2	E	300	0.26	0.14	EEEFK1E101AL	(6)	1000
	150	8.0	10.2	F	600	0.16	0.14	EEEFK1E151AL	(6)	500
	220	8.0	10.2	F	600	0.16	0.14	EEEFK1E221AL	(6)	500
	330	8.0	10.2	F	600	0.16	0.14	EEEFK1E331AL	(6)	500
	470	10.0	10.2	G	850	0.08	0.14	EEEFK1E471AL	(6)	500
35	33	6.3	5.8	D	240	0.36	0.12	EEEFK1V330AL	(5)	1000
	47	6.3	5.8	D	240	0.36	0.12	EEEFK1V470AL	(5)	1000
	68	6.3	7.7	D8	280	0.34	0.12	EEEFKV680XAL	(5)	900
	100	6.3	7.7	D8	280	0.34	0.12	EEEFKV101XAL	(5)	900
		8.0	10.2	F	600	0.16	0.12	EEEFK1V101AL	(6)	500
	150	8.0	10.2	F	600	0.16	0.12	EEEFK1V151AL	(6)	500
	220	8.0	10.2	F	600	0.16	0.12	EEEFK1V221AL	(6)	500
	330	10.0	10.2	G	850	0.08	0.12	EEEFK1V331AL	(6)	500

*1: Ripple current (100 kHz / +105 °C)

*2: Impedance (100 kHz / +20 °C)

*3: tan δ (120 Hz / +20 °C)

- If Part number exceeds 12 digits, voltage code is abbreviated as follows; 0J → J, 1A → A, 1C → C, 1E → E, 1V → V
- Please refer to the page of "Reflow Profile" and "The Taping Dimensions".

Surface Mount Type

FK series

V type



Features

- Endurance : 105 °C 2000 h to 5000 h
- Low impedance (40 % to 60 % less than FC series)
- Miniaturized (30 % to 50 % less than FC series)
- Vibration-proof product (30G guaranteed) is available upon request ($\phi 6.3 \leq$)
- AEC-Q200 compliant
- RoHS compliant

Specifications

Category temp. range	-55 °C to +105 °C										
Rated voltage range	6.3 V to 100 V										
Capacitance range	3.3 μ F to 6800 μ F										
Capacitance tolerance	$\pm 20\%$ (120 Hz / +20 °C)										
Leakage current	$I \leq 0.01 CV$ or 3 (μ A) After 2 minutes (Whichever is greater)										
Dissipation factor (tan δ)	Please see the attached characteristics list										
Characteristics at low temperature	Rated voltage (V)	6.3	10	16	25	35	50	63	80	100	(Impedance ratio at 120 Hz)
	Z (-25 °C) / Z (+20 °C)	2	2	2	2	2	2	2	2	2	
	Z (-40 °C) / Z (+20 °C)	3	3	3	3	3	3	3	3	3	
Endurance	After applying rated working voltage for 2000 hours at +105 °C ± 2 °C and then being stabilized at +20 °C, capacitors shall meet the following limits. ($\geq \phi 12.5$ and suffix "G" in $\phi 8 \times 10.2$, $\phi 10 \times 10.2$ are 5000 hours)										
	Capacitance change	Within $\pm 30\%$ of the initial value (Suffix "G" is 35 %)									
	Dissipation factor (tan δ)	$\leq 200\%$ of the initial limit (Suffix "G" is 300 %)									
	Leakage current	Within the initial limit									
Shelf life	After storage for 1000 hours at +105 °C ± 2 °C with no voltage applied and then being stabilized at +20 °C, capacitors shall meet the limits specified in endurance. (With voltage treatment)										
Resistance to soldering heat	After reflow soldering and then being stabilized at +20 °C, capacitors shall meet the following limits.										
	Capacitance change	Within $\pm 10\%$ of the initial value									
	Dissipation factor (tan δ)	Within the initial limit									
	Leakage current	Within the initial limit									

Frequency correction factor for ripple current

Frequency (Hz)	50, 60	120	1 k	10 k	100 k to
Correction factor	0.70	0.75	0.90	0.95	1.00

Marking

Example : 6.3 V 22 μ F, 6.3 V 3300 μ F
Marking color : BLACK

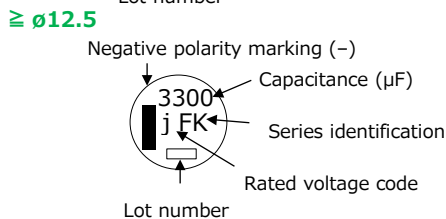
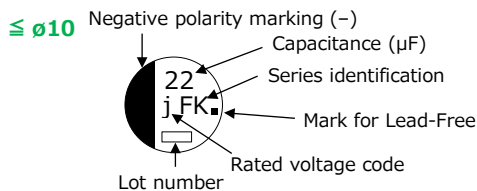

R. voltage code		Unit : V	
j	6.3	H	50
A	10	J	63
C	16	K	80
E	25	2A	100
V	35		

Dimensions

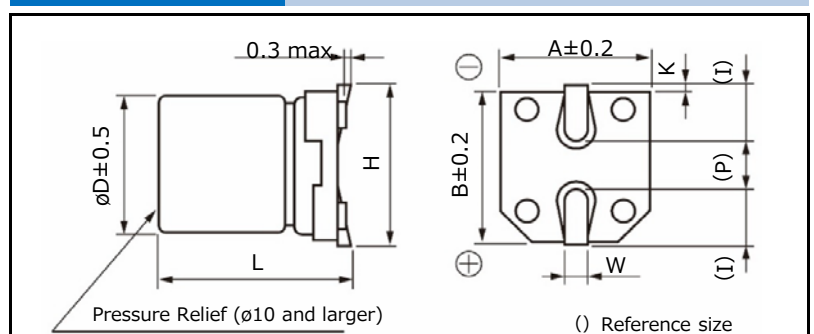

Size code	ϕD	L	A, B	H	I	W	P	K
B	4.0	5.8 \pm 0.3	4.3	5.5 max.	1.8	0.65 \pm 0.1	1.0	0.35 ^{+0.15} _{-0.20}
C	5.0	5.8 \pm 0.3	5.3	6.5 max.	2.2	0.65 \pm 0.1	1.5	0.35 ^{+0.15} _{-0.20}
D	6.3	5.8 \pm 0.3	6.6	7.8 max.	2.6	0.65 \pm 0.1	1.8	0.35 ^{+0.15} _{-0.20}
D8	6.3	7.7 \pm 0.3	6.6	7.8 max.	2.6	0.65 \pm 0.1	1.8	0.35 ^{+0.15} _{-0.20}
E	8.0	6.2 \pm 0.3	8.3	9.5 max.	3.4	0.65 \pm 0.1	2.2	0.35 ^{+0.15} _{-0.20}
F	8.0	10.2 \pm 0.3	8.3	10.0 max.	3.4	0.90 \pm 0.2	3.1	0.70 \pm 0.2
G	10.0	10.2 \pm 0.3	10.3	12.0 max.	3.5	0.90 \pm 0.2	4.6	0.70 \pm 0.2
H13	12.5	13.5 \pm 0.5	13.5	15.0 max.	4.7	0.90 \pm 0.3	4.4	0.70 \pm 0.3
J16	16.0	16.5 \pm 0.5	17.0	19.0 max.	5.5	1.20 \pm 0.3	6.7	0.70 \pm 0.3
K16	18.0	16.5 \pm 0.5	19.0	21.0 max.	6.7	1.20 \pm 0.3	6.7	0.70 \pm 0.3

*The dimensions of the vibration-proof products, please refer to the page of the mounting specification.

Characteristics list

Endurance : 105 °C 2000 h (≥ ø12.5 : 5000 h)

Rated voltage (V)	Capacitance (±20 %) (μF)	Case size (mm)			Size code*1	Specification			Part No.		Reflow	Min. Packaging Q'ty (pcs)
		øD	L			Ripple current*2 (mA rms)	Impedance*3 (Ω)	tan δ*4	Standard Product	Vibration-proof product		Taping
			Standard	Vibration-proof								
6.3	22	4.0	5.8	—	B	90	1.35	0.26	EEEFK0J220R	—	(1)	2000
	47	4.0	5.8	—	(B)	90	1.35	0.26	EEEFK0J470UR	—	(1)	2000
		5.0	5.8	—	C	160	0.70	0.26	EEEFK0J470R	—	(1)	1000
	100	5.0	5.8	—	(C)	160	0.70	0.26	EEEFK0J101UR	—	(1)	1000
		6.3	5.8	6.1	D	240	0.36	0.26	EEEFK0J101P	EEEFK0J101V	(1)	1000
	220	6.3	5.8	6.1	D	240	0.36	0.26	EEEFK0J221P	EEEFK0J221V	(1)	1000
	330	6.3	7.7	8.0	D8	280	0.34	0.26	EEEFK0J331XP	EEEFK0J331XV	(1)	900
		8.0	6.2	6.5	E	300	0.26	0.26	EEEFK0J331P	EEEFK0J331V	(2)	1000
	470	8.0	10.2	10.5	F	600	0.16	0.26	EEEFK0J471P	EEEFK0J471V	(2)	500
	1000	8.0	10.2	10.5	F	600	0.16	0.26	EEEFK0J102P	EEEFK0J102V	(2)	500
	1500	10.0	10.2	10.5	G	850	0.08	0.26	EEEFK0J152P	EEEFK0J152V	(2)	500
	3300	12.5	13.5	13.8	H13	1100	0.06	0.30	EEVFK0J332Q	EEVFK0J332V	(3)	200
6800	16.0	16.5	16.8	J16	1800	0.035	0.36	EEVFK0J682M	EEVFK0J682V	(3)	125	
10	22	4.0	5.8	—	B	90	1.35	0.19	EEEFK1A220R	—	(1)	2000
	33	4.0	5.8	—	(B)	90	1.35	0.19	EEEFK1A330UR	—	(1)	2000
		5.0	5.8	—	C	160	0.70	0.19	EEEFK1A330R	—	(1)	1000
	150	6.3	5.8	6.1	D	240	0.36	0.19	EEEFK1A151P	EEEFK1A151V	(1)	1000
	220	6.3	7.7	8.0	D8	280	0.34	0.19	EEEFK1A221XP	EEEFK1A221XV	(1)	900
		8.0	6.2	6.5	E	300	0.26	0.19	EEEFK1A221P	EEEFK1A221V	(2)	1000
	330	8.0	10.2	10.5	F	600	0.16	0.19	EEEFK1A331P	EEEFK1A331V	(2)	500
	470	8.0	10.2	10.5	F	600	0.16	0.19	EEEFK1A471P	EEEFK1A471V	(2)	500
	680	8.0	10.2	10.5	F	600	0.16	0.19	EEEFK1A681P	EEEFK1A681V	(2)	500
	1000	10.0	10.2	10.5	G	850	0.08	0.19	EEEFK1A102P	EEEFK1A102V	(2)	500
	2200	12.5	13.5	13.8	H13	1100	0.06	0.21	EEVFK1A222Q	EEVFK1A222V	(3)	200
	4700	16.0	16.5	16.8	J16	1800	0.035	0.25	EEVFK1A472M	EEVFK1A472V	(3)	125
6800	18.0	16.5	16.8	K16	2060	0.033	0.29	EEVFK1A682M	EEVFK1A682V	(3)	125	
16	10	4.0	5.8	—	B	90	1.35	0.16	EEEFK1C100R	—	(1)	2000
	22	4.0	5.8	—	(B)	90	1.35	0.16	EEEFK1C220UR	—	(1)	2000
		5.0	5.8	—	C	160	0.70	0.16	EEEFK1C220R	—	(1)	1000
	47	5.0	5.8	—	(C)	160	0.70	0.16	EEEFK1C470UR	—	(1)	1000
		6.3	5.8	6.1	D	240	0.36	0.16	EEEFK1C470P	EEEFK1C470V	(1)	1000
	68	6.3	5.8	6.1	D	240	0.36	0.16	EEEFK1C680P	EEEFK1C680V	(1)	1000
	100	6.3	5.8	6.1	D	240	0.36	0.16	EEEFK1C101P	EEEFK1C101V	(1)	1000
	150	6.3	7.7	8.0	D8	280	0.34	0.16	EEEFK1C151XP	EEEFK1C151XV	(1)	900
	220	6.3	7.7	8.0	D8	280	0.34	0.16	EEEFK1C221XP	EEEFK1C221XV	(1)	900
		8.0	6.2	6.5	E	300	0.26	0.16	EEEFK1C221P	EEEFK1C221V	(2)	1000
	330	8.0	10.2	10.5	F	600	0.16	0.16	EEEFK1C331P	EEEFK1C331V	(2)	500
	470	8.0	10.2	10.5	F	600	0.16	0.16	EEEFK1C471P	EEEFK1C471V	(2)	500
680	10.0	10.2	10.5	G	850	0.08	0.16	EEEFK1C681P	EEEFK1C681V	(2)	500	
1500	12.5	13.5	13.8	H13	1100	0.06	0.16	EEVFK1C152Q	EEVFK1C152V	(3)	200	
3300	16.0	16.5	16.8	J16	1800	0.035	0.20	EEVFK1C332M	EEVFK1C332V	(3)	125	
4700	18.0	16.5	16.8	K16	2060	0.033	0.22	EEVFK1C472M	EEVFK1C472V	(3)	125	
25	10	4.0	5.8	—	B	90	1.35	0.14	EEEFK1E100R	—	(1)	2000
	22	5.0	5.8	—	C	160	0.70	0.14	EEEFK1E220R	—	(1)	1000
		5.0	5.8	—	(C)	160	0.70	0.14	EEEFK1E330UR	—	(1)	1000
	33	6.3	5.8	6.1	D	240	0.36	0.14	EEEFK1E330P	EEEFK1E330V	(1)	1000
		6.3	5.8	6.1	D	240	0.36	0.14	EEEFK1E470P	EEEFK1E470V	(1)	1000
	68	6.3	5.8	6.1	D	240	0.36	0.14	EEEFK1E680P	EEEFK1E680V	(1)	1000
	100	6.3	7.7	8.0	D8	280	0.34	0.14	EEEFK1E101XP	EEEFK1E101XV	(1)	900
		8.0	6.2	6.5	E	300	0.26	0.14	EEEFK1E101P	EEEFK1E101V	(2)	1000
	150	8.0	10.2	10.5	F	600	0.16	0.14	EEEFK1E151P	EEEFK1E151V	(2)	500
	220	8.0	10.2	10.5	F	600	0.16	0.14	EEEFK1E221P	EEEFK1E221V	(2)	500
	330	8.0	10.2	10.5	F	600	0.16	0.14	EEEFK1E331P	EEEFK1E331V	(2)	500
	470	10.0	10.2	10.5	G	850	0.08	0.14	EEEFK1E471P	EEEFK1E471V	(2)	500
1000	12.5	13.5	13.8	H13	1100	0.06	0.14	EEVFK1E102Q	EEVFK1E102V	(3)	200	
1500	16.0	16.5	16.8	J16	1800	0.035	0.14	EEVFK1E152M	EEVFK1E152V	(3)	125	
2200	16.0	16.5	16.8	J16	1800	0.035	0.16	EEVFK1E222M	EEVFK1E222V	(3)	125	
3300	18.0	16.5	16.8	K16	2060	0.033	0.18	EEVFK1E332M	EEVFK1E332V	(3)	125	

*1: Size code(): Miniaturization product

*2: Ripple current (100 kHz / +105 °C)

*3: Impedance (100 kHz / +20 °C)

*4: tan δ (120 Hz / +20 °C)

• Please refer to the page of "Reflow Profile" and "The Taping Dimensions".

Characteristics list

Endurance : 105 °C 2000 h (≥ ø12.5 : 5000 h)

Rated voltage (V)	Capacitance (±20 %) (μF)	Case size (mm)			Size code*1	Specification			Part No.		Reflow	Min. Packaging Q'ty (pcs)
		øD	L			Ripple current*2 (mA rms)	Impedance*3 (Ω)	tan δ*4	Standard Product	Vibration-proof product		
			Standard	Vibration-proof								Taping
35	4.7	4.0	5.8	—	B	90	1.35	0.12	EEEFK1V4R7R	—	(1)	2000
	10	4.0	5.8	—	(B)	90	1.35	0.12	EEEFK1V100UR	—	(1)	2000
		5.0	5.8	—	C	160	0.70	0.12	EEEFK1V100R	—	(1)	1000
	22	5.0	5.8	—	C	160	0.70	0.12	EEEFK1V220R	—	(1)	1000
	33	6.3	5.8	6.1	D	240	0.36	0.12	EEEFK1V330P	EEEFK1V330V	(1)	1000
	47	6.3	5.8	6.1	D	240	0.36	0.12	EEEFK1V470P	EEEFK1V470V	(1)	1000
	68	6.3	7.7	8	D8	280	0.34	0.12	EEEFK1V680XP	EEEFK1V680XV	(1)	900
	100	6.3	7.7	8	D8	280	0.34	0.12	EEEFK1V101XP	EEEFK1V101XV	(1)	900
		8.0	10.2	10.5	F	600	0.16	0.12	EEEFK1V101P	EEEFK1V101V	(2)	500
	150	8.0	10.2	10.5	F	600	0.16	0.12	EEEFK1V151P	EEEFK1V151V	(2)	500
	220	8.0	10.2	10.5	F	600	0.16	0.12	EEEFK1V221P	EEEFK1V221V	(2)	500
	330	10.0	10.2	10.5	G	850	0.08	0.12	EEEFK1V331P	EEEFK1V331V	(2)	500
	470	12.5	13.5	13.8	H13	1100	0.06	0.12	EEVFK1V471Q	EEVFK1V471V	(3)	200
	680	12.5	13.5	13.8	H13	1100	0.06	0.12	EEVFK1V681Q	EEVFK1V681V	(3)	200
	1000	16.0	16.5	16.8	J16	1800	0.035	0.12	EEVFK1V102M	EEVFK1V102V	(3)	125
1500	16.0	16.5	16.8	J16	1800	0.035	0.12	EEVFK1V152M	EEVFK1V152V	(3)	125	
50	4.7	4.0	5.8	—	B	60	2.90	0.10	EEEFK1H4R7R	—	(1)	2000
	10	5.0	5.8	—	(C)	85	1.52	0.10	EEEFK1H100UR	—	(1)	1000
		6.3	5.8	6.1	D	165	0.88	0.10	EEEFK1H100P	EEEFK1H100V	(1)	1000
	22	6.3	5.8	6.1	D	165	0.88	0.10	EEEFK1H220P	EEEFK1H220V	(1)	1000
	33	6.3	7.7	8	D8	195	0.68	0.10	EEEFK1H330XP	EEEFK1H330XV	(1)	900
		8.0	6.2	6.5	E	195	0.68	0.10	EEEFK1H330P	EEEFK1H330V	(2)	1000
	47	6.3	7.7	8	D8	195	0.68	0.10	EEEFK1H470XP	EEEFK1H470XV	(1)	900
		8.0	6.2	6.5	E	195	0.68	0.10	EEEFK1H470P	EEEFK1H470V	(2)	1000
	100	8.0	10.2	10.5	F	350	0.34	0.10	EEEFK1H101P	EEEFK1H101V	(2)	500
	150	10.0	10.2	10.5	G	670	0.18	0.10	EEEFK1H151P	EEEFK1H151V	(2)	500
	220	10.0	10.2	10.5	G	670	0.18	0.10	EEEFK1H221P	EEEFK1H221V	(2)	500
	330	12.5	13.5	13.8	H13	900	0.12	0.10	EEVFK1H331Q	EEVFK1H331V	(3)	200
	390	12.5	13.5	13.8	H13	900	0.12	0.10	EEVFK1H391Q	EEVFK1H391V	(3)	200
	470	16.0	16.5	16.8	J16	1610	0.073	0.10	EEVFK1H471M	EEVFK1H471V	(3)	125
	560	16.0	16.5	16.8	J16	1610	0.073	0.10	EEVFK1H561M	EEVFK1H561V	(3)	125
680	16.0	16.5	16.8	J16	1610	0.073	0.10	EEVFK1H681M	EEVFK1H681V	(3)	125	
1000	16.0	16.5	16.8	J16	1610	0.073	0.10	EEVFK1H102M	EEVFK1H102V	(3)	125	
63	4.7	5.0	5.8	—	C	50	3.00	0.08	EEEFK1J4R7R	—	(1)	1000
	10	6.3	5.8	6.1	D	80	1.50	0.08	EEEFK1J100P	EEEFK1J100V	(1)	1000
		6.3	7.7	8	D8	120	1.20	0.08	EEEFK1J220XP	EEEFK1J220XV	(1)	900
	22	8.0	6.2	6.5	E	120	1.20	0.08	EEEFK1J220P	EEEFK1J220V	(2)	1000
		8.0	10.2	10.5	F	250	0.65	0.08	EEEFK1J330P	EEEFK1J330V	(2)	500
	47	8.0	10.2	10.5	F	250	0.65	0.08	EEEFK1J470P	EEEFK1J470V	(2)	500
	68	8.0	10.2	10.5	(F)	250	0.65	0.08	EEEFK1J680UP	EEEFK1J680UV	(2)	500
	100	10.0	10.2	10.5	G	400	0.35	0.08	EEEFK1J101P	EEEFK1J101V	(2)	500
	150	12.5	13.5	13.8	H13	800	0.16	0.08	EEVFK1J151Q	EEVFK1J151V	(3)	200
	220	12.5	13.5	13.8	H13	800	0.16	0.08	EEVFK1J221Q	EEVFK1J221V	(3)	200
80	470	16.0	16.5	16.8	J16	1410	0.082	0.08	EEVFK1J471M	EEVFK1J471V	(3)	125
	680	18.0	16.5	16.8	K16	1690	0.08	0.08	EEVFK1J681M	EEVFK1J681V	(3)	125
	3.3	5.0	5.8	—	C	25	5.00	0.08	EEEFK1K3R3R	—	(1)	1000
	4.7	6.3	5.8	6.1	D	40	3.00	0.08	EEEFK1K4R7P	EEEFK1K4R7V	(1)	1000
80	10	6.3	7.7	8	D8	60	2.40	0.08	EEEFK1K100XP	EEEFK1K100XV	(1)	900
		8.0	6.2	6.5	E	60	2.40	0.08	EEEFK1K100P	EEEFK1K100V	(2)	1000
	22	8.0	10.2	10.5	F	130	1.30	0.08	EEEFK1K220P	EEEFK1K220V	(2)	500
	33	8.0	10.2	10.5	F	130	1.30	0.08	EEEFK1K330P	EEEFK1K330V	(2)	500
	47	10.0	10.2	10.5	G	200	0.70	0.08	EEEFK1K470P	EEEFK1K470V	(2)	500
	68	12.5	13.5	13.8	H13	500	0.32	0.08	EEVFK1K680Q	EEVFK1K680V	(3)	200
	100	12.5	13.5	13.8	H13	500	0.32	0.08	EEVFK1K101Q	EEVFK1K101V	(3)	200
	150	12.5	13.5	13.8	H13	500	0.32	0.08	EEVFK1K151Q	EEVFK1K151V	(3)	200
	330	16.0	16.5	16.8	J16	793	0.17	0.08	EEVFK1K331M	EEVFK1K331V	(3)	125
	470	18.0	16.5	16.8	K16	917	0.153	0.08	EEVFK1K471M	EEVFK1K471V	(3)	125

*1: Size code (): Miniaturization product

*2: Ripple current (100 kHz / +105 °C)

*3: Impedance (100 kHz / +20 °C)

*4: tan δ (120 Hz / +20 °C)

• Please refer to the page of "Reflow Profile" and "The Taping Dimensions".

Characteristics list

Endurance : 105 °C 2000 h (≥ ø12.5 : 5000 h)

Rated voltage (V)	Capacitance (±20 %) (µF)	Case size (mm)			Size code *1	Specification			Part No.		Reflow	Min. Packaging Q'ty (pcs)
		øD	L			Ripple current*2 (mA rms)	Impe-dance*3 (Ω)	tan δ*4	Standard Product	Vibration-proof product		Taping
			Standard	Vibration -proof								
100	22	8.0	10.2	10.5	F	130	1.30	0.07	EEEFK2A220P	EEEFK2A220V	(2)	500
	33	10.0	10.2	10.5	G	200	0.70	0.07	EEEFK2A330P	EEEFK2A330V	(2)	500
	47	12.5	13.5	13.8	H13	500	0.32	0.07	EEVFK2A470Q	EEVFK2A470V	(3)	200
	68	12.5	13.5	13.8	H13	500	0.32	0.07	EEVFK2A680Q	EEVFK2A680V	(3)	200
	100	16.0	16.5	16.8	J16	793	0.17	0.07	EEVFK2A101M	EEVFK2A101V	(3)	125
	150	16.0	16.5	16.8	J16	793	0.17	0.07	EEVFK2A151M	EEVFK2A151V	(3)	125
	220	18.0	16.5	16.8	K16	917	0.153	0.07	EEVFK2A221M	EEVFK2A221V	(3)	125
	330	18.0	16.5	16.8	K16	917	0.153	0.07	EEVFK2A331M	EEVFK2A331V	(3)	125

Endurance : 105 °C 5000 h

Rated voltage (V)	Capacitance (±20 %) (µF)	Case size (mm)			Size code *1	Specification			Part No.		Reflow	Min. Packaging Q'ty (pcs)
		øD	L			Ripple current*2 (mA rms)	Impe-dance*3 (Ω)	tan δ*4	Standard Product	Vibration-proof product		Taping
			Standard	Vibration -proof								
6.3	470	8.0	10.2	10.5	F	600	0.16	0.26	EEEFK0J471GP	EEEFK0J471GV	(2)	500
	1000	8.0	10.2	10.5	F	600	0.16	0.26	EEEFK0J102GP	EEEFK0J102GV	(2)	500
	1500	10.0	10.2	10.5	G	850	0.08	0.26	EEEFK0J152GP	EEEFK0J152GV	(2)	500
10	330	8.0	10.2	10.5	F	600	0.16	0.19	EEEFK1A331GP	EEEFK1A331GV	(2)	500
	470	8.0	10.2	10.5	F	600	0.16	0.19	EEEFK1A471GP	EEEFK1A471GV	(2)	500
	680	8.0	10.2	10.5	F	600	0.16	0.19	EEEFK1A681GP	EEEFK1A681GV	(2)	500
	1000	10.0	10.2	10.5	G	850	0.08	0.19	EEEFK1A102GP	EEEFK1A102GV	(2)	500
16	330	8.0	10.2	10.5	F	600	0.16	0.16	EEEFK1C331GP	EEEFK1C331GV	(2)	500
	470	8.0	10.2	10.5	F	600	0.16	0.16	EEEFK1C471GP	EEEFK1C471GV	(2)	500
	680	10.0	10.2	10.5	G	850	0.08	0.16	EEEFK1C681GP	EEEFK1C681GV	(2)	500
25	150	8.0	10.2	10.5	F	600	0.16	0.14	EEEFK1E151GP	EEEFK1E151GV	(2)	500
	220	8.0	10.2	10.5	F	600	0.16	0.14	EEEFK1E221GP	EEEFK1E221GV	(2)	500
	330	8.0	10.2	10.5	F	600	0.16	0.14	EEEFK1E331GP	EEEFK1E331GV	(2)	500
	470	10.0	10.2	10.5	G	850	0.08	0.14	EEEFK1E471GP	EEEFK1E471GV	(2)	500
35	100	8.0	10.2	10.5	F	600	0.16	0.12	EEEFK1V101GP	EEEFK1V101GV	(2)	500
	150	8.0	10.2	10.5	F	600	0.16	0.12	EEEFK1V151GP	EEEFK1V151GV	(2)	500
	220	8.0	10.2	10.5	F	600	0.16	0.12	EEEFK1V221GP	EEEFK1V221GV	(2)	500
	330	10.0	10.2	10.5	G	850	0.08	0.12	EEEFK1V331GP	EEEFK1V331GV	(2)	500
50	100	8.0	10.2	10.5	F	350	0.34	0.10	EEEFK1H101GP	EEEFK1H101GV	(2)	500
	150	10.0	10.2	10.5	G	670	0.18	0.10	EEEFK1H151GP	EEEFK1H151GV	(2)	500
	220	10.0	10.2	10.5	G	670	0.18	0.10	EEEFK1H221GP	EEEFK1H221GV	(2)	500

*1: Ripple current (100 kHz / +105 °C)

*2: Impedance (100 kHz / +20 °C)

*3: tan δ (120 Hz / +20 °C)

• Please refer to the page of "Reflow Profile" and "The Taping Dimensions".

Surface Mount Type Halogen-free FK series V type



Features

- Endurance : 105 °C 2000 h to 5000 h
- Low impedance (40 % to 60 % less than FC series)
- Miniaturized (30 % to 50 % less than FC series)
- AEC-Q200 compliant
- RoHS compliant

Country of origin

- Malaysia

Specifications

Category temp. range	-55 °C to +105 °C										
Rated voltage range	6.3 V to 100 V										
Capacitance range	4.7 μF to 1500 μF										
Capacitance tolerance	±20 % (120 Hz / +20 °C)										
Leakage current	I ≤ 0.01 CV or 3 (μA) After 2 minutes (Whichever is greater)										
Dissipation factor (tan δ)	Please see the attached characteristics list										
Characteristics at low temperature	Rated voltage (V)	6.3	10	16	25	35	50	63	80	100	(Impedance ratio at 120 Hz)
	Z (-25 °C) / Z (+20 °C)	2	2	2	2	2	2	2	2	2	
	Z (-40 °C) / Z (+20 °C)	3	3	3	3	3	3	3	3	3	
	Z (-55 °C) / Z (+20 °C)	4	4	4	3	3	3	3	3	3	
Endurance	After applying rated working voltage for 2000 hours at +105 °C ± 2 °C and then being stabilized at +20 °C, capacitors shall meet the following limits.(Suffix "G" is 5000 h)										
	Capacitance change	Within ±30 % of the initial value (Suffix "G" is 35 %)									
	Dissipation factor (tan δ)	≤ 200 % of the initial limit (Suffix "G" is 300 %)									
	Leakage current	Within the initial limit									
Shelf life	After storage for 1000 hours at +105 °C ± 2 °C with no voltage applied and then being stabilized at +20 °C, capacitors shall meet the limits specified in endurance. (With voltage treatment)										
Resistance to soldering heat	After reflow soldering and then being stabilized at +20 °C, capacitors shall meet the following limits.										
	Capacitance change	Within ±10 % of the initial value									
	Dissipation factor (tan δ)	Within the initial limit									
	Leakage current	Within the initial limit									

Frequency correction factor for ripple current

Frequency (Hz)	50, 60	120	1 k	10 k	100 k to
Correction factor	0.70	0.75	0.90	0.95	1.00

Marking

Example : 50 V 10 μF
Marking color : BLACK

Negative polarity marking (-)

Capacitance (μF)
Series identification
Mark for Lead-Free products (Black dot)
Rated voltage code
Lot number

R. voltage code	Unit : V
j	6.3
A	10
C	16
E	25
V	35

Unit : V	Code
50	H
63	J
80	K
100	2A

Dimensions

0.3 max.
øD±0.5
L
A±0.2
H
I
W
P
K
Pressure Relief (ø10 and larger)
() Reference size

Unit : mm

Size code	øD	L	A, B	H	I	W	P	K
D	6.3	5.8±0.3	6.6	7.8 max.	2.6	0.65±0.1	1.8	0.35 ^{+0.15} _{-0.20}
D8	6.3	7.7±0.3	6.6	7.8 max.	2.6	0.65±0.1	1.8	0.35 ^{+0.15} _{-0.20}
E	8.0	6.2±0.3	8.3	9.5 max.	3.4	0.65±0.1	2.2	0.35 ^{+0.15} _{-0.20}
F	8.0	10.2±0.3	8.3	10.0 max.	3.4	0.90±0.2	3.1	0.70±0.2
G	10.0	10.2±0.3	10.3	12.0 max.	3.5	0.90±0.2	4.6	0.70±0.2

Characteristics list

Endurance : 105 °C 2000 h

Rated voltage (V)	Capacitance (±20 %) (μF)	Case size (mm)		Size code*1	Specification			Part number	Reflow	Min. Packaging Q'ty (pcs)
		øD	L		Ripple current*2 (mA rms)	Impedance*3 (Ω)	tanδ*4			Taping
50	10	6.3	5.8	D	165	0.88	0.10	EEEFK1H100L	(1)	1000
	22	6.3	5.8	D	165	0.88	0.10	EEEFK1H220L	(1)	1000
	33	6.3	7.7	D8	195	0.68	0.10	EEEFK1H330XL	(1)	900
		8.0	6.2	E	195	0.68	0.10	EEEFK1H330L	(2)	1000
	47	6.3	7.7	D8	195	0.68	0.10	EEEFK1H470XL	(1)	900
		8.0	6.2	E	195	0.68	0.10	EEEFK1H470L	(2)	1000
	100	8.0	10.2	F	350	0.34	0.10	EEEFK1H101L	(2)	500
150	10.0	10.2	G	670	0.18	0.10	EEEFK1H151L	(2)	500	
220	10.0	10.2	G	670	0.18	0.10	EEEFK1H221L	(2)	500	
63	10	6.3	5.8	D	80	1.50	0.08	EEEFK1J100L	(1)	1000
	22	6.3	7.7	D8	120	1.20	0.08	EEEFK1J220XL	(1)	900
		8.0	6.2	E	120	1.20	0.08	EEEFK1J220L	(2)	1000
	33	8.0	10.2	F	250	0.65	0.08	EEEFK1J330L	(2)	500
	47	8.0	10.2	F	250	0.65	0.08	EEEFK1J470L	(2)	500
	68	8.0	10.2	(F)	250	0.65	0.08	EEEFK1J680UL	(2)	500
100	10.0	10.2	G	400	0.35	0.08	EEEFK1J101L	(2)	500	
80	4.7	6.3	5.8	D	40	3.00	0.08	EEEFK1K4R7L	(1)	1000
	10	6.3	7.7	D8	60	2.40	0.08	EEEFK1K100XL	(1)	900
		8.0	6.2	E	60	2.40	0.08	EEEFK1K100L	(2)	1000
	22	8.0	10.2	F	130	1.30	0.08	EEEFK1K220L	(2)	500
	33	8.0	10.2	F	130	1.30	0.08	EEEFK1K330L	(2)	500
47	10.0	10.2	G	200	0.70	0.08	EEEFK1K470L	(2)	500	
100	22	8.0	10.2	F	130	1.30	0.07	EEEFK2A220L	(2)	500
	33	10.0	10.2	G	200	0.70	0.07	EEEFK2A330L	(2)	500

Endurance : 105 °C 5000 h

Rated voltage (V)	Capacitance (±20 %) (μF)	Case size (mm)		Size code*1	Specification			Part number	Reflow	Min. Packaging Q'ty (pcs)
		øD	L		Ripple current*2 (mA rms)	Impedance*3 (Ω)	tanδ*4			Taping
6.3	470	8.0	10.2	F	600	0.16	0.26	EEEFK0J471GL	(2)	500
	1000	8.0	10.2	F	600	0.16	0.26	EEEFK0J102GL	(2)	500
	1500	10.0	10.2	G	850	0.08	0.26	EEEFK0J152GL	(2)	500
10	330	8.0	10.2	F	600	0.16	0.19	EEEFK1A331GL	(2)	500
	470	8.0	10.2	F	600	0.16	0.19	EEEFK1A471GL	(2)	500
	680	8.0	10.2	F	600	0.16	0.19	EEEFK1A681GL	(2)	500
	1000	10.0	10.2	G	850	0.08	0.19	EEEFK1A102GL	(2)	500
16	330	8.0	10.2	F	600	0.16	0.16	EEEFK1C331GL	(2)	500
	470	8.0	10.2	F	600	0.16	0.16	EEEFK1C471GL	(2)	500
	680	10.0	10.2	G	850	0.08	0.16	EEEFK1C681GL	(2)	500
25	150	8.0	10.2	F	600	0.16	0.14	EEEFK1E151GL	(2)	500
	220	8.0	10.2	F	600	0.16	0.14	EEEFK1E221GL	(2)	500
	330	8.0	10.2	F	600	0.16	0.14	EEEFK1E331GL	(2)	500
	470	10.0	10.2	G	850	0.08	0.14	EEEFK1E471GL	(2)	500
35	100	8.0	10.2	F	600	0.16	0.12	EEEFK1V101GL	(2)	500
	150	8.0	10.2	F	600	0.16	0.12	EEEFK1V151GL	(2)	500
	220	8.0	10.2	F	600	0.16	0.12	EEEFK1V221GL	(2)	500
	330	10.0	10.2	G	850	0.08	0.12	EEEFK1V331GL	(2)	500
50	100	8.0	10.2	F	350	0.34	0.10	EEEFK1H101GL	(2)	500
	150	10.0	10.2	G	670	0.18	0.10	EEEFK1H151GL	(2)	500
	220	10.0	10.2	G	670	0.18	0.10	EEEFK1H221GL	(2)	500

*1: Size code (): Miniaturization product

*2: Ripple current (100 kHz / +105 °C)

*3: Impedance (100 kHz / +20 °C)

*4: tan δ (120 Hz / +20 °C)

• Please refer to the page of "Reflow Profile" and "The Taping Dimensions".

Surface Mount Type

FKS series **V** type

6.3 V to 50 V : High temperature Lead-Free reflow

63 V to 100 V : Standard Lead-Free reflow



Features

- Endurance : 105 °C 2000 h
- 1 size smaller than series FK
- Vibration-proof product (30G guaranteed) is available upon request ($\phi 6.3 \leq$)
- AEC-Q200 compliant
- RoHS compliant

Specifications

Category temp. range	-55 °C to +105 °C										
Rated voltage range	6.3 V to 100 V										
Capacitance range	10 μ F to 1800 μ F										
Capacitance tolerance	± 20 % (120 Hz / +20 °C)										
Leakage current	I \leq 0.01 CV or 3 (μ A) After 2 minutes (Whichever is greater)										
Dissipation factor (tan δ)	Please see the attached characteristics list										
Characteristics at low temperature	Rated voltage (V)	6.3	10	16	25	35	50	63	80	100	(Impedance ratio at 120 Hz)
	Z (-25 °C) / Z (+20 °C)	2	2	2	2	2	2	2	2	2	
	Z (-40 °C) / Z (+20 °C)	3	3	3	3	3	3	3	3	3	
	Z (-55 °C) / Z (+20 °C)	4	4	4	3	3	3	3	3	3	
Endurance	After applying rated working voltage for 2000 hours at +105 °C \pm 2 °C and then being stabilized at +20 °C, capacitors shall meet the following limits.										
	Capacitance change	Within ± 30 % of the initial value (6.3 V of B, C size : Within ± 40 %)									
	Dissipation factor (tan δ)	≤ 200 % of the initial limit									
	Leakage current	Within the initial limit									
Shelf life	After storage for 1000 hours at +105 °C \pm 2 °C with no voltage applied and then being stabilized at +20 °C, capacitors shall meet the limits specified in endurance. (With voltage treatment)										
Resistance to soldering heat	After reflow soldering and then being stabilized at +20 °C, capacitors shall meet the following limits.										
	Capacitance change	Within ± 10 % of the initial value									
	Dissipation factor (tan δ)	Within the initial limit									
	Leakage current	Within the initial limit									

Frequency correction factor for ripple current

Frequency (Hz)	120	1 k	10 k	100 k to
Correction factor	0.65	0.85	0.95	1.00

Marking

Example : 6.3 V 270 μ F
Marking color : BLACK

Negative polarity marking (-)

Capacitance (μ F)

Series identification

Rated voltage code

Lot number

R.voltage code		Unit : V	
j	6.3	H	50
A	10	J	63
C	16	K	80
E	25	2A	100
V	35		

Dimensions

0.3 max.

$\phi D \pm 0.5$

L

H

A ± 0.2

B ± 0.2

K

P

T

W

() Reference size

Unit : mm								
Size code	ϕD	L	A, B	H	I	W	P	K
B	4.0	5.8 \pm 0.3	4.3	5.5 max.	1.8	0.65 \pm 0.1	1.0	0.35 ^{+0.15} _{-0.20}
C	5.0	5.8 \pm 0.3	5.3	6.5 max.	2.2	0.65 \pm 0.1	1.5	0.35 ^{+0.15} _{-0.20}
D	6.3	5.8 \pm 0.3	6.6	7.8 max.	2.6	0.65 \pm 0.1	1.8	0.35 ^{+0.15} _{-0.20}
D8	6.3	7.7 \pm 0.3	6.6	7.8 max.	2.6	0.65 \pm 0.1	1.8	0.35 ^{+0.15} _{-0.20}
F	8.0	10.2 \pm 0.3	8.3	10.0 max.	3.4	0.90 \pm 0.2	3.1	0.70 \pm 0.2
G	10.0	10.2 \pm 0.3	10.3	12.0 max.	3.5	0.90 \pm 0.2	4.6	0.70 \pm 0.2

*The dimensions of the vibration-proof products, please refer to the page of the mounting specification.

Characteristics list

■ 6.3 V to 50 V (High temperature reflow)

Endurance : 105 °C 2000 h

Rated voltage (V)	Capacitance (±20 %) (μF)	Case size (mm)			Size code	Specification			Part No.		Reflow	Min. Packaging Q'ty (pcs)
		øD	L			Ripple current*1 (mA rms)	ESR*2 (Ω)	tan δ*3	Standard Product	Vibration-proof product		
			Standard	Vibration-proof								Taping
6.3	68	4.0	5.8	—	B	90	1.35	0.26	EEEFK0J680SR	—	(5)	2000
	150	5.0	5.8	—	C	160	0.70	0.26	EEEFK0J151SR	—	(5)	1000
	270	6.3	5.8	6.1	D	240	0.36	0.26	EEEFK0J271SP	EEEFK0J271SV	(5)	1000
	470	6.3	7.7	8.0	D8	280	0.34	0.26	EEEFKJ471XSP	EEEFKJ471XSV	(5)	900
	1800	10.0	10.2	10.5	G	850	0.08	0.26	EEEFK0J182SP	EEEFK0J182SV	(6)	500
10	56	4.0	5.8	—	B	90	1.35	0.19	EEEFK1A560SR	—	(5)	2000
	120	5.0	5.8	—	C	160	0.70	0.19	EEEFK1A121SR	—	(5)	1000
	220	6.3	5.8	6.1	D	240	0.36	0.19	EEEFK1A221SP	EEEFK1A221SV	(5)	1000
	330	6.3	7.7	8.0	D8	280	0.34	0.19	EEEFKA331XSP	EEEFKA331XSV	(5)	900
	820	8.0	10.2	10.5	F	600	0.16	0.19	EEEFK1A821SP	EEEFK1A821SV	(6)	500
	1200	10.0	10.2	10.5	G	850	0.08	0.19	EEEFK1A122SP	EEEFK1A122SV	(6)	500
16	1500	10.0	10.2	10.5	G	850	0.08	0.19	EEEFK1A152SP	EEEFK1A152SV	(6)	500
	47	4.0	5.8	—	B	90	1.35	0.16	EEEFK1C470SR	—	(5)	2000
	100	5.0	5.8	—	C	160	0.70	0.16	EEEFK1C101SR	—	(5)	1000
	150	6.3	5.8	6.1	D	240	0.36	0.16	EEEFK1C151SP	EEEFK1C151SV	(5)	1000
	270	6.3	7.7	8.0	D8	280	0.34	0.16	EEEFK1C271XSP	EEEFK1C271XSV	(5)	900
	560	8.0	10.2	10.5	F	600	0.16	0.16	EEEFK1C561SP	EEEFK1C561SV	(6)	500
	680	8.0	10.2	10.5	F	600	0.16	0.16	EEEFK1C681SP	EEEFK1C681SV	(6)	500
25	1000	10.0	10.2	10.5	G	850	0.08	0.16	EEEFK1C102SP	EEEFK1C102SV	(6)	500
	27	4.0	5.8	—	B	90	1.35	0.14	EEEFK1E270SR	—	(5)	2000
	56	5.0	5.8	—	C	160	0.70	0.14	EEEFK1E560SR	—	(5)	1000
	100	6.3	5.8	6.1	D	240	0.36	0.14	EEEFK1E101SP	EEEFK1E101SV	(5)	1000
	150	6.3	7.7	8.0	D8	280	0.34	0.14	EEEFKE151XSP	EEEFKE151XSV	(5)	900
	180	6.3	7.7	8.0	D8	280	0.34	0.14	EEEFKE181XSP	EEEFKE181XSV	(5)	900
	390	8.0	10.2	10.5	F	600	0.16	0.14	EEEFK1E391SP	EEEFK1E391SV	(6)	500
	470	8.0	10.2	10.5	F	600	0.16	0.14	EEEFK1E471SP	EEEFK1E471SV	(6)	500
35	680	10.0	10.2	10.5	G	850	0.08	0.14	EEEFK1E681SP	EEEFK1E681SV	(6)	500
	820	10.0	10.2	10.5	G	850	0.08	0.14	EEEFK1E821SP	EEEFK1E821SV	(6)	500
	18	4.0	5.8	—	B	90	1.35	0.12	EEEFK1V180SR	—	(5)	2000
	39	5.0	5.8	—	C	160	0.70	0.12	EEEFK1V390SR	—	(5)	1000
	68	6.3	5.8	6.1	D	240	0.36	0.12	EEEFK1V680SP	EEEFK1V680SV	(5)	1000
	82	6.3	5.8	6.1	D	240	0.36	0.12	EEEFK1V820SP	EEEFK1V820SV	(5)	1000
	120	6.3	7.7	8.0	D8	280	0.34	0.12	EEEFKV121XSP	EEEFKV121XSV	(5)	900
	270	8.0	10.2	10.5	F	600	0.16	0.12	EEEFK1V271SP	EEEFK1V271SV	(6)	500
	330	8.0	10.2	10.5	F	600	0.16	0.12	EEEFK1V331SP	EEEFK1V331SV	(6)	500
50	470	10.0	10.2	10.5	G	850	0.08	0.12	EEEFK1V471SP	EEEFK1V471SV	(6)	500
	560	10.0	10.2	10.5	G	850	0.08	0.12	EEEFK1V561SP	EEEFK1V561SV	(6)	500
	10	4.0	5.8	—	B	60	3.50	0.10	EEEFK1H100SR	—	(5)	2000
	22	5.0	5.8	—	C	85	1.52	0.10	EEEFK1H220SR	—	(5)	1000
	39	6.3	5.8	6.1	D	165	0.88	0.10	EEEFK1H390SP	EEEFK1H390SV	(5)	1000
	82	6.3	7.7	8.0	D8	195	0.68	0.10	EEEFKH820XSP	EEEFKH820XSV	(5)	900
	180	8.0	10.2	10.5	F	350	0.34	0.10	EEEFK1H181SP	EEEFK1H181SV	(6)	500
	270	10.0	10.2	10.5	G	670	0.18	0.10	EEEFK1H271SP	EEEFK1H271SV	(6)	500

*1: Ripple current (100 kHz / +105 °C)

*2: ESR (100 kHz / +20 °C)

*3: tan δ (120 Hz / +20 °C)

• If Part number exceeds 12 digits, voltage code is abbreviated as follows; 0J → J, 1A → A, 1C → C, 1E → E, 1V → V, 1H → H

• Please refer to the page of "Reflow Profile" and "The Taping Dimensions".

Characteristics list

■ 63 V to 100 V (Standard reflow)

Endurance : 105 °C 2000 h

Rated voltage (V)	Capacitance (±20 %) (μF)	Case size (mm)			Size code	Specification			Part No.		Reflow	Min. Packaging Q'ty (pcs)
		øD	L			Ripple current* ¹ (mA rms)	ESR* ² (Ω)	tan δ* ³	Standard Product	Vibration-proof product		Taping
			Standard	Vibration-proof								
63	120	10.0	10.2	10.5	G	400	0.35	0.08	EEEFK1J121SP	EEEFK1J121SV	(2)	500
80	47	8.0	10.2	10.5	F	130	1.30	0.08	EEEFK1K470SP	EEEFK1K470SV	(2)	500
	82	10.0	10.2	10.5	G	200	0.70	0.08	EEEFK1K820SP	EEEFK1K820SV	(2)	500
100	27	8.0	10.2	10.5	F	130	1.30	0.07	EEEFK2A270SP	EEEFK2A270SV	(2)	500
	47	10.0	10.2	10.5	G	200	0.70	0.07	EEEFK2A470SP	EEEFK2A470SV	(2)	500

*1: Ripple current (100 kHz / +105 °C)

*2: ESR (100 kHz / +20 °C)

*3: tan δ (120 Hz / +20 °C)

- If Part number exceeds 12 digits, voltage code is abbreviated as follows; 0J → J, 1A → A, 1C → C, 1E → E, 1V → V, 1H → H

- Please refer to the page of "Reflow Profile" and "The Taping Dimensions".

Surface Mount Type

Medium-size **FKS** series **V** type

High temperature **Lead-Free reflow**



Features

- Endurance : 105 °C 5000 h
- High capacitance : 20 to 80 % higher than FK series, large capacitance up to 13000 µF
- Vibration-proof product (30G guaranteed) is available upon request
- AEC-Q200 compliant
- RoHS compliant

Specifications

Category temp. range	-55 °C to +105 °C					
Rated voltage range	6.3 V to 35 V					
Capacitance range	750 µF to 13000 µF					
Capacitance tolerance	±20 % (120 Hz / +20 °C)					
Leakage current	I ≤ 0.01 CV (µA) After 2 minutes					
Dissipation factor (tan δ)	Please see the attached characteristics list					
Characteristics at low temperature	Rated voltage (V)	6.3	10	16	25	35
	Z (-25 °C) / Z (+20 °C)	2	2	2	2	2
	Z (-40 °C) / Z (+20 °C)	3	3	3	3	3
	Z (-55 °C) / Z (+20 °C)	4	4	4	3	3
Endurance	After applying rated working voltage for 5000 hours at +105 °C ± 2 °C and then being stabilized at +20 °C, capacitors shall meet the following limits.					
	Capacitance change	Within ±30 % of the initial value				
	Dissipation factor (tan δ)	≤ 300 % of the initial limit				
	Leakage current	Within the initial limit				
Shelf life	After storage for 1000 hours at +105 °C ± 2 °C with no voltage applied and then being stabilized at +20 °C, capacitors shall meet the limits specified in endurance. (With voltage treatment)					
	Capacitance change	Within ±30 % of the initial value				
	Dissipation factor (tan δ)	≤ 200 % of the initial limit				
	Leakage current	Within the initial limit				
Resistance to soldering heat	After reflow soldering and then being stabilized at +20 °C, capacitors shall meet the following limits.					
	Capacitance change	Within ±10 % of the initial value				
	Dissipation factor (tan δ)	Within the initial limit				
	Leakage current	Within the initial limit				

Frequency correction factor for ripple current

Frequency (Hz)	120	1 k	10 k	100 k to
Correction factor	0.75	0.90	0.95	1.00

Marking

Example : 6.3 V 3500 µF
Marking color : BLACK

Negative polarity marking (-)

Capacitance (µF)

Series identification

Mark for Lead-Free products (Black dot)

Rated voltage code

Lot number

R.voltage code		Unit : V	
j	6.3	E	25
A	10	V	35
C	16		

Dimensions

() Reference size

Size code	øD	L	A, B	H	I	W	P	K
H13	12.5	13.5±0.5	13.5	15.0 max.	4.7	0.90±0.3	4.4	0.70±0.3
J16	16.0	16.5±0.5	17.0	19.0 max.	5.5	1.20±0.3	6.7	0.70±0.3
K16	18.0	16.5±0.5	19.0	21.0 max.	6.7	1.20±0.3	6.7	0.70±0.3
K21	18.0	21.5±0.5	19.0	21.0 max.	6.7	1.20±0.3	6.7	0.70±0.3

Unit : mm

*The dimensions of the vibration-proof products, please refer to the page of the mounting specification.

Characteristics list

Endurance : 105 °C 5000 h

Rated voltage (V)	Capacitance (±20 %) (μF)	Case size (mm)			Size code	Specification			Part No.		Reflow	Min. Packaging Q'ty (pcs)
		øD	L			Ripple current*1 (mA rms)	Impe-dance*2 (Ω)	tan δ*3	Standard Product	Vibration-proof product		Taping
			Standard	Vibration -proof								
6.3	3500	12.5	13.5	13.8	H13	1100	0.06	0.30	EEEFK0J352SQ	EEEFK0J352SV	(9)	200
	7500	16.0	16.5	16.8	J16	1800	0.035	0.38	EEEFK0J752SM	EEEFK0J752SV	(9)	125
	10000	18.0	16.5	16.8	K16	2060	0.033	0.42	EEEFK0J103SM	EEEFK0J103SV	(9)	125
	13000	18.0	21.5	21.8	K21	2640	0.025	0.50	EEEFK0J133SM	EEEFK0J133SV	(9)	75
10	2400	12.5	13.5	13.8	H13	1100	0.06	0.21	EEEFK1A242SQ	EEEFK1A242SV	(9)	200
	5600	16.0	16.5	16.8	J16	1800	0.035	0.27	EEEFK1A562SM	EEEFK1A562SV	(9)	125
	7500	18.0	16.5	16.8	K16	2060	0.033	0.31	EEEFK1A752SM	EEEFK1A752SV	(9)	125
	9100	18.0	21.5	21.8	K21	2640	0.025	0.35	EEEFK1A912SM	EEEFK1A912SV	(9)	75
16	1800	12.5	13.5	13.8	H13	1100	0.06	0.16	EEEFK1C182SQ	EEEFK1C182SV	(9)	200
	4300	16.0	16.5	16.8	J16	1800	0.035	0.22	EEEFK1C432SM	EEEFK1C432SV	(9)	125
	5600	18.0	16.5	16.8	K16	2060	0.033	0.24	EEEFK1C562SM	EEEFK1C562SV	(9)	125
	7500	18.0	21.5	21.8	K21	2640	0.025	0.28	EEEFK1C752SM	EEEFK1C752SV	(9)	75
25	1200	12.5	13.5	13.8	H13	1100	0.06	0.14	EEEFK1E122SQ	EEEFK1E122SV	(9)	200
	2700	16.0	16.5	16.8	J16	1800	0.035	0.16	EEEFK1E272SM	EEEFK1E272SV	(9)	125
	3600	18.0	16.5	16.8	K16	2060	0.033	0.18	EEEFK1E362SM	EEEFK1E362SV	(9)	125
	4700	18.0	21.5	21.8	K21	2640	0.025	0.20	EEEFK1E472SM	EEEFK1E472SV	(9)	75
35	750	12.5	13.5	13.8	H13	1100	0.06	0.12	EEEFK1V751SQ	EEEFK1V751SV	(9)	200
	1600	16.0	16.5	16.8	J16	1800	0.035	0.14	EEEFK1V162SM	EEEFK1V162SV	(9)	125
	2200	18.0	16.5	16.8	K16	2060	0.033	0.14	EEEFK1V222SM	EEEFK1V222SV	(9)	125
	3000	18.0	21.5	21.8	K21	2640	0.025	0.16	EEEFK1V302SM	EEEFK1V302SV	(9)	75

*1: Ripple current (100 kHz / +105 °C)

*2: Impedance (100 kHz / +20 °C)

*3: tan δ (120 Hz / +20 °C)

• Please refer to the page of "Reflow Profile" and "The Taping Dimensions".

Surface Mount Type

Halogen-free FKS series **V** type

6.3 V to 50 V : High temperature Lead-Free reflow

63 V to 100 V : Standard Lead-Free reflow



Features

- Endurance : 105 °C 2000 h
- 1 size smaller than series FK
- AEC-Q200 compliant
- RoHS compliant

Country of origin

- Malaysia

Specifications

Category temp. range	-55 °C to +105 °C										
Rated voltage range	6.3 V to 100 V										
Capacitance range	27 µF to 1800 µF										
Capacitance tolerance	±20 % (120 Hz / +20 °C)										
Leakage current	I ≤ 0.01 CV or 3 (µA) After 2 minutes (Whichever is greater)										
Dissipation factor (tan δ)	Please see the attached characteristics list										
Characteristics at low temperature	Rated voltage (V)	6.3	10	16	25	35	50	63	80	100	(Impedance ratio at 120 Hz)
	Z (-25 °C) / Z (+20 °C)	2	2	2	2	2	2	2	2	2	
	Z (-40 °C) / Z (+20 °C)	3	3	3	3	3	3	3	3	3	
	Z (-55 °C) / Z (+20 °C)	4	4	4	3	3	3	3	3	3	
Endurance	After applying rated working voltage for 2000 hours at +105 °C ± 2 °C and then being stabilized at +20 °C, capacitors shall meet the following limits.										
	Capacitance change	Within ±30 % of the initial value									
	Dissipation factor (tan δ)	≤ 200 % of the initial limit									
	Leakage current	Within the initial limit									
Shelf life	After storage for 1000 hours at +105 °C ± 2 °C with no voltage applied and then being stabilized at +20 °C, capacitors shall meet the limits specified in endurance. (With voltage treatment)										
Resistance to soldering heat	After reflow soldering and then being stabilized at +20 °C, capacitors shall meet the following limits.										
	Capacitance change	Within ±10 % of the initial value									
	Dissipation factor (tan δ)	Within the initial limit									
	Leakage current	Within the initial limit									

Frequency correction factor for ripple current

Frequency (Hz)	120	1 k	10 k	100 k to
Correction factor	0.65	0.85	0.95	1.00

Marking

Example : 6.3 V 270 µF
Marking color : BLACK

Negative polarity marking (-)

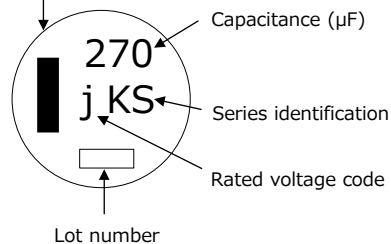

R.voltage code	Unit : V		Unit : V
j	6.3	H	50
A	10	J	63
C	16	K	80
E	25	2A	100
V	35		

Dimensions

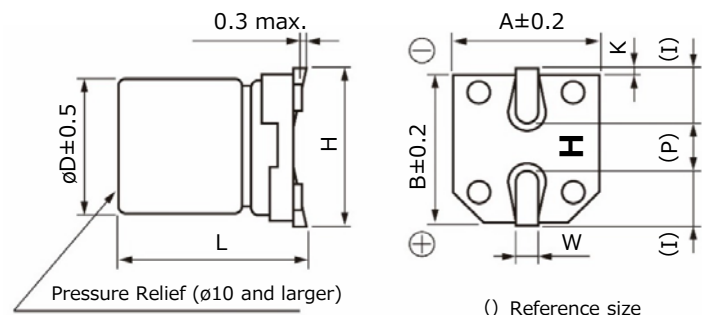

Size code	øD	L	A, B	H	I	W	P	K
D	6.3	5.8±0.3	6.6	7.8 max.	2.6	0.65±0.1	1.8	0.35 ^{+0.15} _{-0.20}
D8	6.3	7.7±0.3	6.6	7.8 max.	2.6	0.65±0.1	1.8	0.35 ^{+0.15} _{-0.20}
F	8.0	10.2±0.3	8.3	10.0 max.	3.4	0.90±0.2	3.1	0.70±0.2
G	10.0	10.2±0.3	10.3	12.0 max.	3.5	0.90±0.2	4.6	0.70±0.2

Characteristics list

■ 6.3 V to 50 V (High temperature reflow)

Endurance : 105 °C 2000 h

Rated voltage (V)	Capacitance (±20 %) (μF)	Case size (mm)		Size code	Specification			Part number	Reflow	Min. Packaging Q'ty (pcs)
		øD	L		Ripple current* ¹ (mA rms)	ESR* ² (Ω)	tanδ* ³			Taping
6.3	270	6.3	5.8	D	240	0.36	0.26	EEEFK0J271SL	(5)	1000
	470	6.3	7.7	D8	280	0.34	0.26	EEEFKJ471XSL	(5)	900
	1800	10.0	10.2	G	850	0.08	0.26	EEEFK0J182SL	(6)	500
10	220	6.3	5.8	D	240	0.36	0.19	EEEFK1A221SL	(5)	1000
	330	6.3	7.7	D8	280	0.34	0.19	EEEFKA331XSL	(5)	900
	820	8.0	10.2	F	600	0.16	0.19	EEEFK1A821SL	(6)	500
	1200	10.0	10.2	G	850	0.08	0.19	EEEFK1A122SL	(6)	500
	1500	10.0	10.2	G	850	0.08	0.19	EEEFK1A152SL	(6)	500
16	150	6.3	5.8	D	240	0.36	0.16	EEEFK1C151SL	(5)	1000
	270	6.3	7.7	D8	280	0.34	0.16	EEEFKC271XSL	(5)	900
	560	8.0	10.2	F	600	0.16	0.16	EEEFK1C561SL	(6)	500
	680	8.0	10.2	F	600	0.16	0.16	EEEFK1C681SL	(6)	500
	1000	10.0	10.2	G	850	0.08	0.16	EEEFK1C102SL	(6)	500
25	100	6.3	5.8	D	240	0.36	0.14	EEEFK1E101SL	(5)	1000
	150	6.3	7.7	D8	280	0.34	0.14	EEEFKE151XSL	(5)	900
	180	6.3	7.7	D8	280	0.34	0.14	EEEFKE181XSL	(5)	900
	390	8.0	10.2	F	600	0.16	0.14	EEEFK1E391SL	(6)	500
	470	8.0	10.2	F	600	0.16	0.14	EEEFK1E471SL	(6)	500
	680	10.0	10.2	G	850	0.08	0.14	EEEFK1E681SL	(6)	500
	820	10.0	10.2	G	850	0.08	0.14	EEEFK1E821SL	(6)	500
35	68	6.3	5.8	D	240	0.36	0.12	EEEFK1V680SL	(5)	1000
	82	6.3	5.8	D	240	0.36	0.12	EEEFK1V820SL	(5)	1000
	120	6.3	7.7	D8	280	0.34	0.12	EEEFKV121XSL	(5)	900
	270	8.0	10.2	F	600	0.16	0.12	EEEFK1V271SL	(6)	500
	330	8.0	10.2	F	600	0.16	0.12	EEEFK1V331SL	(6)	500
	470	10.0	10.2	G	850	0.08	0.12	EEEFK1V471SL	(6)	500
	560	10.0	10.2	G	850	0.08	0.12	EEEFK1V561SL	(6)	500
50	39	6.3	5.8	D	165	0.88	0.10	EEEFK1H390SL	(5)	1000
	82	6.3	7.7	D8	195	0.68	0.10	EEEFKH820XSL	(5)	900
	180	8.0	10.2	F	350	0.34	0.10	EEEFK1H181SL	(6)	500
	270	10.0	10.2	G	670	0.18	0.10	EEEFK1H271SL	(6)	500

■ 63 V to 100 V (Standard reflow)

Endurance : 105 °C 2000 h

Rated voltage (V)	Capacitance (±20 %) (μF)	Case size (mm)		Size code	Specification			Part number	Reflow	Min. Packaging Q'ty (pcs)
		øD	L		Ripple current* ¹ (mA rms)	ESR* ² (Ω)	tanδ* ³			Taping
63	120	10.0	10.2	G	400	0.35	0.08	EEEFK1J121SL	(2)	500
80	47	8.0	10.2	F	130	1.30	0.08	EEEFK1K470SL	(2)	500
	82	10.0	10.2	G	200	0.70	0.08	EEEFK1K820SL	(2)	500
100	27	8.0	10.2	F	130	1.30	0.07	EEEFK2A270SL	(2)	500
	47	10.0	10.2	G	200	0.70	0.07	EEEFK2A470SL	(2)	500

*1: Ripple current (100 kHz / +105 °C)

*2: ESR (100 kHz / +20 °C)

*3: tan δ (120 Hz / +20 °C)

- If Part number exceeds 12 digits, voltage code is abbreviated as follows; 0J → J, 1A → A, 1C → C, 1E → E, 1V → V, 1H → H
- Please refer to the page of "Reflow Profile" and "The Taping Dimensions".

Surface Mount Type

FN series

V type

6.3 V to 50 V

: High temperature Lead-Free reflow

63 V to 100 V

: Standard Lead-Free reflow



Features

- Endurance : 105 °C 2000 h
- Wide voltage range from 6.3 V to 100 V
- High capacitance : 20 % to 80 % higher than FK series
- Vibration-proof product (30G guaranteed) is available upon request ($\phi 6.3 \leq$)
- AEC-Q200 compliant
- RoHS compliant

Specifications

Category temp. range	-55 °C to +105 °C										
Rated voltage range	6.3 V to 100 V										
Capacitance range	10 μ F to 1800 μ F										
Capacitance tolerance	± 20 % (120 Hz / +20°C)										
Leakage current	$I \leq 0.01$ CV or 3 (μ A) After 2 minutes (Whichever is greater)										
Dissipation factor (tan δ)	Please see the attached characteristics list										
Characteristics at low temperature	Rated voltage (V)	6.3	10	16	25	35	50	63	80	100	(Impedance ratio at 120 Hz)
	Z (-25 °C) / Z (+20 °C)	2	2	2	2	2	2	2	2	2	
	Z (-40 °C) / Z (+20 °C)	3	3	3	3	3	3	3	3	3	
	Z (-55 °C) / Z (+20 °C)	4	4	4	3	3	3	3	3	3	
Endurance	After applying rated working voltage for 2000 hours at +105 °C ± 2 °C and then being stabilized at +20 °C, capacitors shall meet the following limits.										
	Capacitance change	Within ± 30 % of the initial value (For 6.3 V, size B/C, and suffix "U" : Within ± 40 %)									
	Dissipation factor (tan δ)	≤ 200 % of the initial limit									
	DC leakage current	Within the initial limit									
Shelf life	After storage for 1000 hours at +105 °C ± 2 °C with no voltage applied and then being stabilized at +20 °C, capacitors shall meet the limits specified in endurance. (With voltage treatment)										
Resistance to soldering heat	After reflow soldering and then being stabilized at +20 °C, capacitors shall meet the following limits.										
	Capacitance change	Within ± 10 % of the initial value									
	Dissipation factor (tan δ)	Within the initial limit									
	DC leakage current	Within the initial limit									

Frequency correction factor for ripple current

Cap. (μ F)	120	1 k	10 k	100 k to
10 to 470	0.65	0.85	0.95	1.00
560 to 1800	0.70	0.90	0.95	1.00

Marking

Example : 6.3 V 10 μ F
Marking color : BLACK

Negative polarity marking (-)

Capacitance (μ F)

Series identification

Rated voltage code

Lot number

R.voltage code		Unit : V	
j	6.3	H	50
A	10	J	63
C	16	K	80
E	25	2A	100
V	35		

Dimensions

() Reference size

Size code	ϕD	L	A, B	H	I	W	P	K
B	4.0	5.8 \pm 0.3	4.3	5.5 max.	1.8	0.65 \pm 0.1	1.0	0.35 ^{+0.15} _{-0.20}
C	5.0	5.8 \pm 0.3	5.3	6.5 max.	2.2	0.65 \pm 0.1	1.5	0.35 ^{+0.15} _{-0.20}
D	6.3	5.8 \pm 0.3	6.6	7.8 max.	2.6	0.65 \pm 0.1	1.8	0.35 ^{+0.15} _{-0.20}
D8	6.3	7.7 \pm 0.3	6.6	7.8 max.	2.6	0.65 \pm 0.1	1.8	0.35 ^{+0.15} _{-0.20}
F	8.0	10.2 \pm 0.3	8.3	10.0 max.	3.4	0.90 \pm 0.2	3.1	0.70 \pm 0.2
G	10.0	10.2 \pm 0.3	10	12.0 max.	3.5	0.90 \pm 0.2	4.6	0.70 \pm 0.2

Unit : mm

*The dimensions of the vibration-proof products, please refer to the page of the mounting specification.

Characteristics list

■ 6.3 V to 50 V (High temperature reflow)

Endurance : 105 °C 2000 h

Rated voltage (V)	Capacitance (±20 %) (μF)	Case size (mm)			Size code	Specification			Part No.		Reflow	Min. Packaging Q'ty (pcs)
		øD	L			Ripple current* ¹ (mA rms)	ESR* ² (Ω)	tan δ* ³	Standard Product	Vibration-proof product		
			Standard	Vibration-proof								Taping
6.3	10	4.0	5.8	—	B	90	1.35	0.26	EEEFN0J100R	—	(5)	2000
	22	4.0	5.8	—	B	90	1.35	0.26	EEEFN0J220R	—	(5)	2000
	33	4.0	5.8	—	B	90	1.35	0.26	EEEFN0J330R	—	(5)	2000
	47	4.0	5.8	—	B	90	1.35	0.26	EEEFN0J470R	—	(5)	2000
	68	4.0	5.8	—	B	90	1.35	0.26	EEEFN0J680UR	—	(5)	2000
	100	5.0	5.8	—	C	160	0.70	0.26	EEEFN0J101R	—	(5)	1000
	150	5.0	5.8	—	C	160	0.70	0.26	EEEFN0J151UR	—	(5)	1000
	220	6.3	5.8	6.1	D	240	0.36	0.26	EEEFN0J221P	EEEFN0J221V	(5)	1000
	270	6.3	5.8	6.1	D	240	0.36	0.26	EEEFN0J271UP	EEEFN0J271UV	(5)	1000
	330	6.3	7.7	8.0	D8	280	0.34	0.26	EEEFN0J331XP	EEEFN0J331XV	(5)	900
	470	6.3	7.7	8.0	D8	280	0.34	0.26	EEEFN0J471XUP	EEEFN0J471XUV	(5)	900
	680	8.0	10.2	10.5	F	600	0.16	0.26	EEEFN0J681P	EEEFN0J681V	(6)	500
	1000	8.0	10.2	10.5	F	600	0.16	0.26	EEEFN0J102P	EEEFN0J102V	(6)	500
	1500	10.0	10.2	10.5	G	850	0.08	0.26	EEEFN0J152P	EEEFN0J152V	(6)	500
	1800	10.0	10.2	10.5	G	850	0.08	0.26	EEEFN0J182UP	EEEFN0J182UV	(6)	500
10	10	4.0	5.8	—	B	90	1.35	0.19	EEEFN1A100R	—	(5)	2000
	22	4.0	5.8	—	B	90	1.35	0.19	EEEFN1A220R	—	(5)	2000
	33	4.0	5.8	—	B	90	1.35	0.19	EEEFN1A330R	—	(5)	2000
	47	4.0	5.8	—	B	90	1.35	0.19	EEEFN1A470UR	—	(5)	2000
	56	4.0	5.8	—	B	90	1.35	0.19	EEEFN1A560UR	—	(5)	2000
	68	5.0	5.8	—	C	160	0.70	0.19	EEEFN1A680R	—	(5)	1000
	100	5.0	5.8	—	C	160	0.70	0.19	EEEFN1A101UR	—	(5)	1000
	120	5.0	5.8	—	C	160	0.70	0.19	EEEFN1A121UR	—	(5)	1000
	150	6.3	5.8	6.1	D	240	0.36	0.19	EEEFN1A151P	EEEFN1A151V	(5)	1000
	220	6.3	5.8	6.1	D	240	0.36	0.19	EEEFN1A221UP	EEEFN1A221UV	(5)	1000
	330	6.3	7.7	8.0	D8	280	0.34	0.19	EEEFN1A331XUP	EEEFN1A331XUV	(5)	900
	470	8.0	10.2	10.5	F	600	0.16	0.19	EEEFN1A471P	EEEFN1A471V	(6)	500
	680	8.0	10.2	10.5	F	600	0.16	0.19	EEEFN1A681P	EEEFN1A681V	(6)	500
	820	8.0	10.2	10.5	F	600	0.16	0.19	EEEFN1A821UP	EEEFN1A821UV	(6)	500
	1000	10.0	10.2	10.5	G	850	0.08	0.19	EEEFN1A102P	EEEFN1A102V	(6)	500
1200	10.0	10.2	10.5	G	850	0.08	0.19	EEEFN1A122UP	EEEFN1A122UV	(6)	500	
1500	10.0	10.2	10.5	G	850	0.08	0.19	EEEFN1A152UP	EEEFN1A152UV	(6)	500	
16	10	4.0	5.8	—	B	90	1.35	0.16	EEEFN1C100R	—	(5)	2000
	22	4.0	5.8	—	B	90	1.35	0.16	EEEFN1C220R	—	(5)	2000
	33	4.0	5.8	—	B	90	1.35	0.16	EEEFN1C330R	—	(5)	2000
	47	4.0	5.8	—	B	90	1.35	0.16	EEEFN1C470UR	—	(5)	2000
	68	5.0	5.8	—	C	160	0.70	0.16	EEEFN1C680R	—	(5)	1000
	100	5.0	5.8	—	C	160	0.70	0.16	EEEFN1C101UR	—	(5)	1000
	150	6.3	5.8	6.1	D	240	0.36	0.16	EEEFN1C151UP	EEEFN1C151UV	(5)	1000
	220	6.3	7.7	8.0	D8	280	0.34	0.16	EEEFN1C221XP	EEEFN1C221XV	(5)	900
	270	6.3	7.7	8.0	D8	280	0.34	0.16	EEEFN1C271XUP	EEEFN1C271XUV	(5)	900
	330	8.0	10.2	10.5	F	600	0.16	0.16	EEEFN1C331P	EEEFN1C331V	(6)	500
	470	8.0	10.2	10.5	F	600	0.16	0.16	EEEFN1C471P	EEEFN1C471V	(6)	500
	560	8.0	10.2	10.5	F	600	0.16	0.16	EEEFN1C561UP	EEEFN1C561UV	(6)	500
	680	8.0	10.2	10.5	F	600	0.16	0.16	EEEFN1C681UP	EEEFN1C681UV	(6)	500
1000	10.0	10.2	10.5	G	850	0.08	0.16	EEEFN1C102UP	EEEFN1C102UV	(6)	500	

*1: Ripple current (100 kHz / +105 °C)

*2: ESR (100 kHz / +20 °C)

*3: tan δ (120 Hz / +20 °C)

• If Part number exceeds 12 digits, voltage code is abbreviated as follows; 0J→J, 1A→A, 1C→C

• Please refer to the page of "Reflow Profile" and "The Taping Dimensions".

Characteristics list

■ 6.3 V to 50 V (High temperature reflow)

Endurance : 105 °C 2000 h

Rated voltage (V)	Capacitance (±20 %) (μF)	Case size (mm)			Size code	Specification			Part No.		Reflow	Min. Packaging Q'ty (pcs)
		øD	L			Ripple current* ¹ (mA rms)	ESR* ² (Ω)	tan δ* ³	Standard Product	Vibration-proof product		
			Standard	Vibration-proof								Taping
25	10	4.0	5.8	—	B	90	1.35	0.14	EEEFN1E100R	—	(5)	2000
	22	4.0	5.8	—	B	90	1.35	0.14	EEEFN1E220R	—	(5)	2000
	27	4.0	5.8	—	B	90	1.35	0.14	EEEFN1E270UR	—	(5)	2000
	33	5.0	5.8	—	C	160	0.70	0.14	EEEFN1E330R	—	(5)	1000
	47	5.0	5.8	—	C	160	0.70	0.14	EEEFN1E470R	—	(5)	1000
	56	5.0	5.8	—	C	160	0.70	0.14	EEEFN1E560UR	—	(5)	1000
	68	6.3	5.8	6.1	D	240	0.36	0.14	EEEFN1E680P	EEEFN1E680V	(5)	1000
	100	6.3	5.8	6.1	D	240	0.36	0.14	EEEFN1E101UP	EEEFN1E101UV	(5)	1000
	150	6.3	7.7	8.0	D8	280	0.34	0.14	EEEFNE151XUP	EEEFNE151XUV	(5)	900
	180	6.3	7.7	8.0	D8	280	0.34	0.14	EEEFNE181XUP	EEEFNE181XUV	(5)	900
	220	8.0	10.2	10.5	F	600	0.16	0.14	EEEFN1E221P	EEEFN1E221V	(6)	500
	330	8.0	10.2	10.5	F	600	0.16	0.14	EEEFN1E331P	EEEFN1E331V	(6)	500
	390	8.0	10.2	10.5	F	600	0.16	0.14	EEEFN1E391UP	EEEFN1E391UV	(6)	500
	470	8.0	10.2	10.5	F	600	0.16	0.14	EEEFN1E471UP	EEEFN1E471UV	(6)	500
	680	10.0	10.2	10.5	G	850	0.08	0.14	EEEFN1E681UP	EEEFN1E681UV	(6)	500
820	10.0	10.2	10.5	G	850	0.08	0.14	EEEFN1E821UP	EEEFN1E821UV	(6)	500	
35	10	4.0	5.8	—	B	90	1.35	0.12	EEEFN1V100R	—	(5)	2000
	18	4.0	5.8	—	B	90	1.35	0.12	EEEFN1V180UR	—	(5)	2000
	22	5.0	5.8	—	C	160	0.70	0.12	EEEFN1V220R	—	(5)	1000
	33	5.0	5.8	—	C	160	0.70	0.12	EEEFN1V330R	—	(5)	1000
	39	5.0	5.8	—	C	160	0.70	0.12	EEEFN1V390UR	—	(5)	1000
	47	6.3	5.8	6.1	D	240	0.36	0.12	EEEFN1V470P	EEEFN1V470V	(5)	1000
	68	6.3	5.8	6.1	D	240	0.36	0.12	EEEFN1V680UP	EEEFN1V680UV	(5)	1000
	82	6.3	5.8	6.1	D	240	0.36	0.12	EEEFN1V820UP	EEEFN1V820UV	(5)	1000
	100	6.3	7.7	8.0	D8	280	0.34	0.12	EEEFN1V101XP	EEEFN1V101XV	(5)	900
	120	6.3	7.7	8.0	D8	280	0.34	0.12	EEEFNV121XUP	EEEFNV121XUV	(5)	900
	150	8.0	10.2	10.5	F	600	0.16	0.12	EEEFN1V151P	EEEFN1V151V	(6)	500
	220	8.0	10.2	10.5	F	600	0.16	0.12	EEEFN1V221P	EEEFN1V221V	(6)	500
	270	8.0	10.2	10.5	F	600	0.16	0.12	EEEFN1V271UP	EEEFN1V271UV	(6)	500
	330	8.0	10.2	10.5	F	600	0.16	0.12	EEEFN1V331UP	EEEFN1V331UV	(6)	500
	470	10.0	10.2	10.5	G	850	0.08	0.12	EEEFN1V471UP	EEEFN1V471UV	(6)	500
560	10.0	10.2	10.5	G	850	0.08	0.12	EEEFN1V561UP	EEEFN1V561UV	(6)	500	
50	10	4.0	5.8	—	B	60	3.50	0.10	EEEFN1H100UR	—	(5)	2000
	22	5.0	5.8	—	C	85	1.52	0.10	EEEFN1H220UR	—	(5)	1000
	33	6.3	5.8	6.1	D	165	0.88	0.10	EEEFN1H330P	EEEFN1H330V	(5)	1000
	39	6.3	5.8	6.1	D	165	0.88	0.10	EEEFN1H390UP	EEEFN1H390UV	(5)	1000
	47	6.3	7.7	8.0	D8	195	0.68	0.10	EEEFN1H470XP	EEEFN1H470XV	(5)	900
	68	6.3	7.7	8.0	D8	195	0.68	0.10	EEEFN1H680XP	EEEFN1H680XV	(5)	900
	82	6.3	7.7	8.0	D8	195	0.68	0.10	EEEFNH820XUP	EEEFNH820XUV	(5)	900
	100	8.0	10.2	10.5	F	350	0.34	0.10	EEEFN1H101P	EEEFN1H101V	(6)	500
	150	8.0	10.2	10.5	F	350	0.34	0.10	EEEFN1H151UP	EEEFN1H151UV	(6)	500
	180	8.0	10.2	10.5	F	350	0.34	0.10	EEEFN1H181UP	EEEFN1H181UV	(6)	500
	220	10.0	10.2	10.5	G	670	0.18	0.10	EEEFN1H221P	EEEFN1H221V	(6)	500
270	10.0	10.2	10.5	G	670	0.18	0.10	EEEFN1H271UP	EEEFN1H271UV	(6)	500	

*1: Ripple current (100 kHz / +105 °C)

*2: ESR (100 kHz / +20 °C)

*3: tan δ (120 Hz / +20 °C)

• If Part number exceeds 12 digits, voltage code is abbreviated as follows; 1E→E, 1V→V, 1H→H

• Please refer to the page of "Reflow Profile" and "The Taping Dimensions".

Characteristics list

■ 63 V to 100 V (Standard reflow)

Endurance : 105 °C 2000 h

Rated voltage (V)	Capacitance (±20 %) (μF)	Case size (mm)			Size code	Specification			Part No.		Reflow	Min. Packaging Q'ty (pcs)
		øD	L			Ripple current*1 (mA rms)	ESR*2 (Ω)	tan δ*3	Standard Product	Vibration-proof product		Taping
			Standard	Vibration-proof								
63	10	6.3	5.8	6.1	D	80	1.50	0.08	EEEFN1J100P	EEEFN1J100V	(1)	1000
	22	6.3	7.7	8.0	D8	120	1.20	0.08	EEEFN1J220XP	EEEFN1J220XV	(1)	900
	33	8.0	10.2	10.5	F	250	0.65	0.08	EEEFN1J330P	EEEFN1J330V	(2)	500
	47	8.0	10.2	10.5	F	250	0.65	0.08	EEEFN1J470P	EEEFN1J470V	(2)	500
	68	8.0	10.2	10.5	F	250	0.65	0.08	EEEFN1J680P	EEEFN1J680V	(2)	500
	100	10.0	10.2	10.5	G	400	0.35	0.08	EEEFN1J101P	EEEFN1J101V	(2)	500
	120	10.0	10.2	10.5	G	400	0.35	0.08	EEEFN1J121UP	EEEFN1J121UV	(2)	500
80	10	6.3	7.7	8.0	D8	60	2.40	0.08	EEEFN1K100XP	EEEFN1K100XV	(1)	900
	22	8.0	10.2	10.5	F	130	1.30	0.08	EEEFN1K220P	EEEFN1K220V	(2)	500
	33	8.0	10.2	10.5	F	130	1.30	0.08	EEEFN1K330P	EEEFN1K330V	(2)	500
	47	8.0	10.2	10.5	F	130	1.30	0.08	EEEFN1K470UP	EEEFN1K470UV	(2)	500
	82	10.0	10.2	10.5	G	200	0.70	0.08	EEEFN1K820UP	EEEFN1K820UV	(2)	500
100	10	8.0	10.2	10.5	F	130	1.30	0.07	EEEFN2A100P	EEEFN2A100V	(2)	500
	22	8.0	10.2	10.5	F	130	1.30	0.07	EEEFN2A220P	EEEFN2A220V	(2)	500
	27	8.0	10.2	10.5	F	130	1.30	0.07	EEEFN2A270UP	EEEFN2A270UV	(2)	500
	33	10.0	10.2	10.5	G	200	0.70	0.07	EEEFN2A330P	EEEFN2A330V	(2)	500
	47	10.0	10.2	10.5	G	200	0.70	0.07	EEEFN2A470UP	EEEFN2A470UV	(2)	500

*1: Ripple current (100 kHz / +105 °C)

*2: ESR (100 kHz / +20 °C)

*3: tan δ (120 Hz / +20 °C)

• Please refer to the page of "Reflow Profile" and "The Taping Dimensions".

Surface Mount Type

Halogen-free FN series **V type**

6.3 V to 50 V : **High temperature Lead-Free reflow**
63 V to 100 V : **Standard Lead-Free reflow**



Features

- Endurance : 105 °C 2000 h
- Wide voltage range from 6.3 V to 100 V
- High capacitance : 20 % to 80 % higher than FK series
- AEC-Q200 compliant
- RoHS compliant

Country of origin

- Malaysia

Specifications

Category temp. range	-55 °C to +105 °C									
Rated voltage range	6.3 V to 100 V									
Capacitance range	10 µF to 1800 µF									
Capacitance tolerance	±20 % (120 Hz / +20 °C)									
Leakage current	I ≤ 0.01 CV or 3 (µA) After 2 minutes (Whichever is greater)									
Dissipation factor (tan δ)	Please see the attached characteristics list									
Characteristics at low temperature	Rated voltage (V)	6.3	10	16	25	35	50	63	80	100
	Z (-25 °C) / Z (+20 °C)	2	2	2	2	2	2	2	2	2
	Z (-40 °C) / Z (+20 °C)	3	3	3	3	3	3	3	3	3
	Z (-55 °C) / Z (+20 °C)	4	4	4	3	3	3	3	3	3
Endurance	After applying rated working voltage for 2000 hours at +105 °C ± 2 °C and then being stabilized at +20 °C, capacitors shall meet the following limits.									
	Capacitance change	Within ±30 % of the initial value (For suffix "U" : Within ±40 %)								
	Dissipation factor (tan δ)	≤ 200 % of the initial limit								
	Leakage current	Within the initial limit								
Shelf life	After storage for 1000 hours at +105 °C ± 2 °C with no voltage applied and then being stabilized at +20 °C, capacitors shall meet the limits specified in endurance. (With voltage treatment)									
Resistance to soldering heat	After reflow soldering and then being stabilized at +20 °C, capacitors shall meet the following limits.									
	Capacitance change	Within ±10 % of the initial value								
	Dissipation factor (tan δ)	Within the initial limit								
	Leakage current	Within the initial limit								

Frequency correction factor for ripple current

Cap. (µF)	120	1 k	10 k	100 k to
10 to 470	0.65	0.85	0.95	1.00
560 to 1800	0.70	0.90	0.95	1.00

Marking

Example : 6.3 V 220 µF
Marking color : BLACK

Negative polarity marking (-)

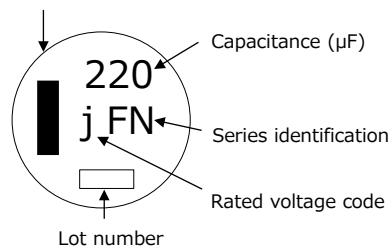

R.voltage code	Unit : V		Unit : V
j	6.3	H	50
A	10	J	63
C	16	K	80
E	25	2A	100
V	35		

Dimensions

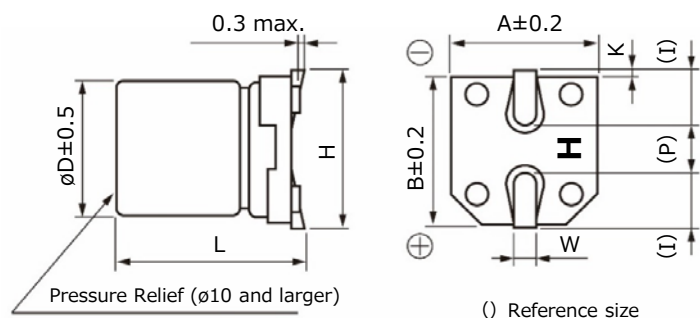

Size code	øD	L	A, B	H	I	W	P	K
D	6.3	5.8±0.3	6.6	7.8 max.	2.6	0.65±0.1	1.8	0.35 ^{+0.15} _{-0.20}
D8	6.3	7.7±0.3	6.6	7.8 max.	2.6	0.65±0.1	1.8	0.35 ^{+0.15} _{-0.20}
F	8.0	10.2±0.3	8.3	10.0 max.	3.4	0.90±0.2	3.1	0.70±0.2
G	10.0	10.2±0.3	10.3	12.0 max.	3.5	0.90±0.2	4.6	0.70±0.2

Characteristics list

■ 6.3 V to 50 V (High temperature reflow)

Endurance : 105 °C 2000 h

Rated voltage (V)	Capacitance (±20 %) (μF)	Case size (mm)		Size code	Specification			Part number	Reflow	Min. Packaging Q'ty (pcs)
		øD	L		Ripple current* ¹ (mA rms)	ESR* ² (Ω)	tanδ* ³			Taping
6.3	220	6.3	5.8	D	240	0.36	0.26	EEEFN0J221L	(5)	1000
	270	6.3	5.8	D	240	0.36	0.26	EEEFN0J271UL	(5)	1000
	330	6.3	7.7	D8	280	0.34	0.26	EEEFN0J331XL	(5)	900
	470	6.3	7.7	D8	280	0.34	0.26	EEEFN0J471XUL	(5)	900
	680	8.0	10.2	F	600	0.16	0.26	EEEFN0J681L	(6)	500
	1000	8.0	10.2	F	600	0.16	0.26	EEEFN0J102L	(6)	500
	1500	10.0	10.2	G	850	0.08	0.26	EEEFN0J152L	(6)	500
10	1800	10.0	10.2	G	850	0.08	0.26	EEEFN0J182UL	(6)	500
	150	6.3	5.8	D	240	0.36	0.19	EEEFN1A151L	(5)	1000
	220	6.3	5.8	D	240	0.36	0.19	EEEFN1A221UL	(5)	1000
	330	6.3	7.7	D8	280	0.34	0.19	EEEFNA331XUL	(5)	900
	470	8.0	10.2	F	600	0.16	0.19	EEEFN1A471L	(6)	500
	680	8.0	10.2	F	600	0.16	0.19	EEEFN1A681L	(6)	500
	820	8.0	10.2	F	600	0.16	0.19	EEEFN1A821UL	(6)	500
16	1000	10.0	10.2	G	850	0.08	0.19	EEEFN1A102L	(6)	500
	1200	10.0	10.2	G	850	0.08	0.19	EEEFN1A122UL	(6)	500
	1500	10.0	10.2	G	850	0.08	0.19	EEEFN1A152UL	(6)	500
	150	6.3	5.8	D	240	0.36	0.16	EEEFN1C151UL	(5)	1000
	220	6.3	7.7	D8	280	0.34	0.16	EEEFN1C221XL	(5)	900
	270	6.3	7.7	D8	280	0.34	0.16	EEEFNC271XUL	(5)	900
	330	8.0	10.2	F	600	0.16	0.16	EEEFN1C331L	(6)	500
25	470	8.0	10.2	F	600	0.16	0.16	EEEFN1C471L	(6)	500
	560	8.0	10.2	F	600	0.16	0.16	EEEFN1C561UL	(6)	500
	680	8.0	10.2	F	600	0.16	0.16	EEEFN1C681UL	(6)	500
	1000	10.0	10.2	G	850	0.08	0.16	EEEFN1C102UL	(6)	500
	68	6.3	5.8	D	240	0.36	0.14	EEEFN1E680L	(5)	1000
	100	6.3	5.8	D	240	0.36	0.14	EEEFN1E101UL	(5)	1000
	150	6.3	7.7	D8	280	0.34	0.14	EEEFNE151XUL	(5)	900
35	180	6.3	7.7	D8	280	0.34	0.14	EEEFNE181XUL	(5)	900
	220	8.0	10.2	F	600	0.16	0.14	EEEFN1E221L	(6)	500
	330	8.0	10.2	F	600	0.16	0.14	EEEFN1E331L	(6)	500
	390	8.0	10.2	F	600	0.16	0.14	EEEFN1E391UL	(6)	500
	470	8.0	10.2	F	600	0.16	0.14	EEEFN1E471UL	(6)	500
	680	10.0	10.2	G	850	0.08	0.14	EEEFN1E681UL	(6)	500
	820	10.0	10.2	G	850	0.08	0.14	EEEFN1E821UL	(6)	500
50	47	6.3	5.8	D	240	0.36	0.12	EEEFN1V470L	(5)	1000
	68	6.3	5.8	D	240	0.36	0.12	EEEFN1V680UL	(5)	1000
	82	6.3	5.8	D	240	0.36	0.12	EEEFN1V820UL	(5)	1000
	100	6.3	7.7	D8	280	0.34	0.12	EEEFN1V101XL	(5)	900
	120	6.3	7.7	D8	280	0.34	0.12	EEEFNV121XUL	(5)	900
	150	8.0	10.2	F	600	0.16	0.12	EEEFN1V151L	(6)	500
	220	8.0	10.2	F	600	0.16	0.12	EEEFN1V221L	(6)	500
50	270	8.0	10.2	F	600	0.16	0.12	EEEFN1V271UL	(6)	500
	330	8.0	10.2	F	600	0.16	0.12	EEEFN1V331UL	(6)	500
	470	10.0	10.2	G	850	0.08	0.12	EEEFN1V471UL	(6)	500
	560	10.0	10.2	G	850	0.08	0.12	EEEFN1V561UL	(6)	500
	33	6.3	5.8	D	165	0.88	0.10	EEEFN1H330L	(5)	1000
	39	6.3	5.8	D	165	0.88	0.10	EEEFN1H390UL	(5)	1000
	47	6.3	7.7	D8	195	0.68	0.10	EEEFN1H470XL	(5)	900
50	68	6.3	7.7	D8	195	0.68	0.10	EEEFN1H680XL	(5)	900
	82	6.3	7.7	D8	195	0.68	0.10	EEEFNH820XUL	(5)	900
	100	8.0	10.2	F	350	0.34	0.10	EEEFN1H101L	(6)	500
	150	8.0	10.2	F	350	0.34	0.10	EEEFN1H151UL	(6)	500
	180	8.0	10.2	F	350	0.34	0.10	EEEFN1H181UL	(6)	500
	220	10.0	10.2	G	670	0.18	0.10	EEEFN1H221L	(6)	500
	270	10.0	10.2	G	670	0.18	0.10	EEEFN1H271UL	(6)	500

*1: Ripple current (100 kHz / +105 °C)

*2: ESR (100 kHz / +20 °C)

*3: tan δ (120 Hz / +20 °C)

· If Part number exceeds 12 digits, voltage code is abbreviated as follows; 0J→J, 1A→A, 1C→C, 1E→E, 1V→V

· Please refer to the page of "Reflow Profile" and "The Taping Dimensions".

Characteristics list

■ 63 V to 100 V (Standard reflow)

Endurance : 105 °C 2000 h

Rated voltage (V)	Capacitance (±20 %) (μF)	Case size (mm)		Size code	Specification			Part number	Reflow	Min. Packaging Q'ty (pcs)
		øD	L		Ripple current* ¹ (mA rms)	ESR* ² (Ω)	tanδ* ³			Taping
63	10	6.3	5.8	D	80	1.50	0.08	EEEFN1J100L	(1)	1000
	22	6.3	7.7	D8	120	1.20	0.08	EEEFN1J220XL	(1)	900
	33	8.0	10.2	F	250	0.65	0.08	EEEFN1J330L	(2)	500
	47	8.0	10.2	F	250	0.65	0.08	EEEFN1J470L	(2)	500
	68	8.0	10.2	F	250	0.65	0.08	EEEFN1J680L	(2)	500
	100	10.0	10.2	G	400	0.35	0.08	EEEFN1J101L	(2)	500
	120	10.0	10.2	G	400	0.35	0.08	EEEFN1J121UL	(2)	500
80	10	6.3	7.7	D8	60	2.40	0.08	EEEFN1K100XL	(1)	900
	22	8.0	10.2	F	130	1.30	0.08	EEEFN1K220L	(2)	500
	33	8.0	10.2	F	130	1.30	0.08	EEEFN1K330L	(2)	500
	47	8.0	10.2	F	130	1.30	0.08	EEEFN1K470UL	(2)	500
	82	10.0	10.2	G	200	0.70	0.08	EEEFN1K820UL	(2)	500
100	10	8.0	10.2	F	130	1.30	0.07	EEEFN2A100L	(2)	500
	22	8.0	10.2	F	130	1.30	0.07	EEEFN2A220L	(2)	500
	27	8.0	10.2	F	130	1.30	0.07	EEEFN2A270UL	(2)	500
	33	10.0	10.2	G	200	0.70	0.07	EEEFN2A330L	(2)	500
	47	10.0	10.2	G	200	0.70	0.07	EEEFN2A470UL	(2)	500

*1: Ripple current (100 kHz / +105 °C)

*2: ESR (100 kHz / +20 °C)

*3: tan δ (120 Hz / +20 °C)

- If Part number exceeds 12 digits, voltage code is abbreviated as follows; 1H→H
- Please refer to the page of "Reflow Profile" and "The Taping Dimensions".

Surface Mount Type

FT series **V** type

High temperature Lead-Free reflow



Features

- Endurance : 105 °C 2000 h to 5000 h
- Miniaturized, Low ESR (1 size smaller than series FK)
- AEC-Q200 compliant
- RoHS compliant

Specifications

Category temp. range	-55 °C to +105 °C	
Rated voltage range	6.3 V to 50 V	
Capacitance range	10 µF to 2200 µF	
Capacitance tolerance	±20 % (120 Hz / +20 °C)	
Leakage current	I ≤ 0.01 CV (µA) After 2 minutes	
Dissipation factor (tan δ)	Please see the attached characteristics list	
Endurance	After applying rated working voltage for 2000 hours at +105 °C ± 2 °C and then being stabilized at +20 °C, capacitors shall meet the following limits. (Suffix "G" in 6.3 V : 3000 hours, 10 V to 50 V : 5000 hours)	
	Capacitance change	Within ±30 % of the initial value (Suffix "G" is ±35 %)
	Dissipation factor (tan δ)	≤ 200 % of the initial limit (Suffix "G" is ≤ 300 %)
	Leakage current	Within the initial limit
Shelf life	After storage for 1000 hours at +105 °C ± 2 °C with no voltage applied and then being stabilized at +20 °C, capacitors shall meet the limits specified in endurance. (With voltage treatment)	
Resistance to soldering heat	After reflow soldering and then being stabilized at +20 °C, capacitors shall meet the following limits.	
	Capacitance change	Within ±10 % of the initial value
	Dissipation factor (tan δ)	Within the initial limit
	Leakage current	Within the initial limit

Frequency correction factor for ripple current

Cap. (µF) \ Freq. (Hz)	120	1 k	10 k	100 k to
10 to 470	0.65	0.85	0.95	1.00
560 to 2200	0.70	0.90	0.95	1.00

Marking

Example : 25 V 22 µF
Marking color : BLACK

Negative polarity marking (-)

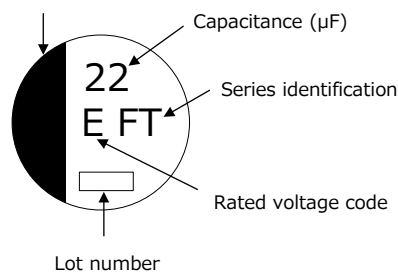

R.voltage code		Unit : V	
j	6.3	E	25
A	10	V	35
C	16	H	50

Dimensions

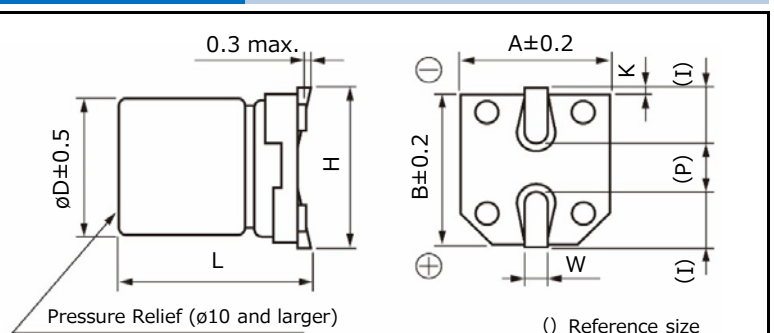

Size code	øD	L	A, B	H	I	W	P	K
B	4.0	5.8±0.3	4.3	5.5 max.	1.8	0.65±0.1	1.0	0.35 ^{+0.15} _{-0.20}
C	5.0	5.8±0.3	5.3	6.5 max.	2.2	0.65±0.1	1.5	0.35 ^{+0.15} _{-0.20}
D	6.3	5.8±0.3	6.6	7.8 max.	2.6	0.65±0.1	1.8	0.35 ^{+0.15} _{-0.20}
D8	6.3	7.7±0.3	6.6	7.8 max.	2.6	0.65±0.1	1.8	0.35 ^{+0.15} _{-0.20}
F	8.0	10.2±0.3	8.3	10.0 max.	3.4	0.90±0.2	3.1	0.70±0.2
G	10.0	10.2±0.3	10.3	12.0 max.	3.5	0.90±0.2	4.6	0.70±0.2

*The dimensions of the vibration-proof products, please refer to the page of the mounting specification.

Characteristics list

Endurance : 105 °C 2000 h

Rated voltage (V)	Capacitance (±20 %) (μF)	Case size (mm)			Size code*1	Specification			Part No.		Reflow	Min. Packaging Q'ty (pcs)
		φD	L			Ripple current*2 (mA rms)	ESR*3 (Ω)	tan δ*4	Standard Product	Vibration-proof product		Taping
			Standard	Vibration-proof								
6.3	100	4.0	5.8	—	B	160	0.85	0.26	EEEFT0J101AR	—	(5)	2000
	220	5.0	5.8	—	C	240	0.36	0.26	EEEFT0J221AR	—	(5)	1000
	330	6.3	5.8	6.1	D	300	0.26	0.26	EEEFT0J331AP	EEEFT0J331AV	(5)	1000
	470	6.3	7.7	8.0	D8	600	0.16	0.26	EEEFTJ471XAP	EEEFTJ471XAV	(5)	900
	680	6.3	7.7	8.0	D8	600	0.16	0.26	EEEFTJ681XAP	EEEFTJ681XAV	(5)	900
	1500	8.0	10.2	10.5	F	850	0.08	0.26	EEEFT0J152AP	EEEFT0J152AV	(6)	500
	2200	10.0	10.2	10.5	G	1190	0.06	0.28	EEEFT0J222AP	EEEFT0J222AV	(6)	500
10	68	4.0	5.8	—	B	160	0.85	0.19	EEEFT1A680AR	—	(5)	2000
	150	5.0	5.8	—	C	240	0.36	0.19	EEEFT1A151AR	—	(5)	1000
	220	6.3	5.8	6.1	D	300	0.26	0.19	EEEFT1A221AP	EEEFT1A221AV	(5)	1000
	330	6.3	7.7	8.0	D8	600	0.16	0.19	EEEFTA331XAP	EEEFTA331XAV	(5)	900
	470	6.3	7.7	8.0	D8	600	0.16	0.19	EEEFTA471XAP	EEEFTA471XAV	(5)	900
	1000	8.0	10.2	10.5	F	850	0.08	0.19	EEEFT1A102AP	EEEFT1A102AV	(6)	500
1500	10.0	10.2	10.5	G	1190	0.06	0.19	EEEFT1A152AP	EEEFT1A152AV	(6)	500	
16	47	4.0	5.8	—	B	160	0.85	0.16	EEEFT1C470AR	—	(5)	2000
	68	5.0	5.8	—	C	240	0.36	0.16	EEEFT1C680AR	—	(5)	1000
	100	5.0	5.8	—	C	240	0.36	0.16	EEEFT1C101AR	—	(5)	1000
	150	6.3	5.8	6.1	D	300	0.26	0.16	EEEFT1C151AP	EEEFT1C151AV	(5)	1000
	220	6.3	5.8	6.1	D	300	0.26	0.16	EEEFT1C221AP	EEEFT1C221AV	(5)	1000
	330	6.3	7.7	8.0	D8	600	0.16	0.16	EEEFTC331XAP	EEEFTC331XAV	(5)	900
	680	8.0	10.2	10.5	F	850	0.08	0.16	EEEFT1C681AP	EEEFT1C681AV	(6)	500
	820	8.0	10.2	10.5	F	850	0.08	0.16	EEEFT1C821UP	EEEFT1C821UV	(6)	500
	1000	10.0	10.2	10.5	G	1190	0.06	0.16	EEEFT1C102AP	EEEFT1C102AV	(6)	500
	1200	10.0	10.2	10.5	G	1190	0.06	0.16	EEEFT1C122UP	EEEFT1C122UV	(6)	500
25	22	4.0	5.8	—	B	160	0.85	0.14	EEEFT1E220AR	—	(5)	2000
	33	4.0	5.8	—	B	160	0.85	0.14	EEEFT1E330AR	—	(5)	2000
	47	5.0	5.8	—	C	240	0.36	0.14	EEEFT1E470AR	—	(5)	1000
	68	5.0	5.8	—	C	240	0.36	0.14	EEEFT1E680AR	—	(5)	1000
	100	6.3	5.8	6.1	D	300	0.26	0.14	EEEFT1E101AP	EEEFT1E101AV	(5)	1000
	150	6.3	7.7	8.0	D8	600	0.16	0.14	EEEFTE151XAP	EEEFTE151XAV	(5)	900
	220	6.3	7.7	8.0	D8	600	0.16	0.14	EEEFTE221XAP	EEEFTE221XAV	(5)	900
	470	8.0	10.2	10.5	F	850	0.08	0.14	EEEFT1E471AP	EEEFT1E471AV	(6)	500
	560	8.0	10.2	10.5	F	850	0.08	0.14	EEEFT1E561UP	EEEFT1E561UV	(6)	500
	820	10.0	10.2	10.5	G	1190	0.06	0.14	EEEFT1E821AP	EEEFT1E821AV	(6)	500
1000	10.0	10.2	10.5	G	1190	0.06	0.14	EEEFT1E102UP	EEEFT1E102UV	(6)	500	
35	22	4.0	5.8	—	B	160	0.85	0.12	EEEFT1V220AR	—	(5)	2000
	33	5.0	5.8	—	C	240	0.36	0.12	EEEFT1V330AR	—	(5)	1000
	47	5.0	5.8	—	C	240	0.36	0.12	EEEFT1V470AR	—	(5)	1000
	68	6.3	5.8	6.1	D	300	0.26	0.12	EEEFT1V680AP	EEEFT1V680AV	(5)	1000
	100	6.3	5.8	6.1	D	300	0.26	0.12	EEEFT1V101AP	EEEFT1V101AV	(5)	1000
	150	6.3	7.7	8.0	D8	600	0.16	0.12	EEEFV151XAP	EEEFV151XAV	(5)	900
	330	8.0	10.2	10.5	F	850	0.08	0.12	EEEFT1V331AP	EEEFT1V331AV	(6)	500
	390	8.0	10.2	10.5	F	850	0.08	0.12	EEEFT1V391UP	EEEFT1V391UV	(6)	500
	560	10.0	10.2	10.5	G	1190	0.06	0.12	EEEFT1V561AP	EEEFT1V561AV	(6)	500
680	10.0	10.2	10.5	G	1190	0.06	0.12	EEEFT1V681UP	EEEFT1V681UV	(6)	500	
50	10	4.0	5.8	—	(B)	85	2.30	0.10	EEEFTH100UAR	—	(5)	2000
		5.0	5.8	—	C	165	0.88	0.10	EEEFT1H100AR	—	(5)	1000
	22	5.0	5.8	—	C	165	0.88	0.10	EEEFT1H220AR	—	(5)	1000
	47	6.3	5.8	6.1	D	195	0.68	0.10	EEEFT1H470AP	EEEFT1H470AV	(5)	1000
	100	6.3	7.7	8.0	D8	350	0.34	0.10	EEEFTH101XAP	EEEFTH101XAV	(5)	900
	220	8.0	10.2	10.5	F	670	0.18	0.10	EEEFT1H221AP	EEEFT1H221AV	(6)	500
330	10.0	10.2	10.5	G	900	0.12	0.10	EEEFT1H331AP	EEEFT1H331AV	(6)	500	

*1: Size code (): Miniaturization product

*2: Ripple current (100 kHz / +105 °C)

*3: ESR (100 kHz / +20 °C)

*4: tan δ (120 Hz / +20 °C)

- If Part number exceeds 12 digits, voltage code is abbreviated as follows; 0J → J, 1A → A, 1C → C, 1E → E, 1V → V, 1H → H
- Please refer to the page of "Reflow Profile" and "The Taping Dimensions".

Characteristics list (Endurance 5000 h)

Endurance : 105 °C 5000 h (6.3 V.DC : 105 °C 3000 h)

Rated voltage (V)	Capacitance (±20 %) (μF)	Case size (mm)			Size code	Specification			Part No.		Reflow	Min. Packaging Q'ty (pcs)
		φD	L			Ripple current* ¹ (mA rms)	ESR* ² (Ω)	tan δ* ³	Standard Product	Vibration-proof product		Taping
			Standard	Vibration-proof								
6.3	1500	8.0	10.2	10.5	F	850	0.08	0.26	EEEFT0J152GP	EEEFT0J152GV	(6)	500
	2200	10.0	10.2	10.5	G	1190	0.06	0.28	EEEFT0J222GP	EEEFT0J222GV	(6)	500
10	1000	8.0	10.2	10.5	F	850	0.08	0.19	EEEFT1A102GP	EEEFT1A102GV	(6)	500
	1500	10.0	10.2	10.5	G	1190	0.06	0.19	EEEFT1A152GP	EEEFT1A152GV	(6)	500
16	680	8.0	10.2	10.5	F	850	0.08	0.16	EEEFT1C681GP	EEEFT1C681GV	(6)	500
	1000	10.0	10.2	10.5	G	1190	0.06	0.16	EEEFT1C102GP	EEEFT1C102GV	(6)	500
25	470	8.0	10.2	10.5	F	850	0.08	0.14	EEEFT1E471GP	EEEFT1E471GV	(6)	500
	820	10.0	10.2	10.5	G	1190	0.06	0.14	EEEFT1E821GP	EEEFT1E821GV	(6)	500
35	330	8.0	10.2	10.5	F	850	0.08	0.12	EEEFT1V331GP	EEEFT1V331GV	(6)	500
	560	10.0	10.2	10.5	G	1190	0.06	0.12	EEEFT1V561GP	EEEFT1V561GV	(6)	500
50	220	8.0	10.2	10.5	F	670	0.18	0.10	EEEFT1H221GP	EEEFT1H221GV	(6)	500
	330	10.0	10.2	10.5	G	900	0.12	0.10	EEEFT1H331GP	EEEFT1H331GV	(6)	500

*1: Ripple current (100 kHz / +105 °C)

*2: ESR (100 kHz / +20 °C)

*3: tan δ (120 Hz / +20 °C)

• Please refer to the page of "Reflow Profile" and "The Taping Dimensions".

Surface Mount Type

Halogen-free FT series V type

High temperature Lead-Free reflow



Features

- Endurance : 105 °C 2000 h
- Miniaturized, Low ESR (1 size smaller than series FK)
- AEC-Q200 compliant
- RoHS compliant

Country of origin

- Malaysia

Specifications

Category temp. range	-55 °C to +105 °C							
Rated voltage range	6.3 V to 50 V							
Capacitance range	47 µF to 2200 µF							
Capacitance tolerance	±20 % (120 Hz / +20 °C)							
Leakage current	I ≤ 0.01 CV (µA) After 2 minutes							
Dissipation factor (tan δ)	Please see the attached characteristics list							
Characteristics at low temperature	Rated voltage (V)	6.3	10	16	25	35	50	(Impedance ratio at 120 Hz)
	Z (-25 °C) / Z (+20 °C)	2	2	2	2	2	2	
	Z (-40 °C) / Z (+20 °C)	3	3	3	3	3	3	
	Z (-55 °C) / Z (+20 °C)	4	4	4	3	3	3	
Endurance	After applying rated working voltage for 2000 hours at +105 °C ± 2 °C and then being stabilized at +20 °C, capacitors shall meet the following limits.							
	Capacitance change	Within ±30 % of the initial value						
	Dissipation factor (tan δ)	≤ 200 % of the initial limit						
	Leakage current	Within the initial limit						
Shelf life	After storage for 1000 hours at +105 °C ± 2 °C with no voltage applied and then being stabilized at +20 °C, capacitors shall meet the limits specified in endurance. (With voltage treatment)							
	After reflow soldering and then being stabilized at +20 °C, capacitors shall meet the following limits.							
Resistance to soldering heat	Capacitance change	Within ±10 % of the initial value						
	Dissipation factor (tan δ)	Within the initial limit						
	Leakage current	Within the initial limit						

Frequency correction factor for ripple current

Cap. (µF) \ Freq. (Hz)	120	1 k	10 k	100 k to
47 to 470	0.65	0.85	0.95	1.00
560 to 2200	0.70	0.90	0.95	1.00

Marking

Example : 6.3 V 330 µF
Marking color : BLACK

Negative polarity marking (-)

Capacitance (µF)

Series identification

Rated voltage code

Lot number

R.voltage code		Unit : V	
j	6.3	E	25
A	10	V	35
C	16	H	50

Dimensions

0.3 max.

Pressure Relief (ø10 and larger)

() Reference size

Unit : mm

Size code	øD	L	A, B	H	I	W	P	K
D	6.3	5.8±0.3	6.6	7.8 max.	2.6	0.65±0.1	1.8	0.35 ^{+0.15} _{-0.20}
D8	6.3	7.7±0.3	6.6	7.8 max.	2.6	0.65±0.1	1.8	0.35 ^{+0.15} _{-0.20}
F	8.0	10.2±0.3	8.3	10.0 max.	3.4	0.90±0.2	3.1	0.70±0.2
G	10.0	10.2±0.3	10.3	12.0 max.	3.5	0.90±0.2	4.6	0.70±0.2

Characteristics list

Endurance : 105 °C 2000 h

Rated voltage (V)	Capacitance (±20 %) (μF)	Case size (mm)		Size code	Specification			Part number	Reflow	Min. Packaging Q'ty (pcs)
		øD	L		Ripple current* ¹ (mA rms)	ESR* ² (Ω)	tanδ* ³			Taping
6.3	330	6.3	5.8	D	300	0.26	0.26	EEEFT0J331AL	(5)	1000
	470	6.3	7.7	D8	600	0.16	0.26	EEEFTJ471XAL	(5)	900
	680	6.3	7.7	D8	600	0.16	0.26	EEEFTJ681XAL	(5)	900
	1500	8.0	10.2	F	850	0.08	0.26	EEEFT0J152AL	(6)	500
	2200	10.0	10.2	G	1190	0.06	0.28	EEEFT0J222AL	(6)	500
10	220	6.3	5.8	D	300	0.26	0.19	EEEFT1A221AL	(5)	1000
	330	6.3	7.7	D8	600	0.16	0.19	EEEFTA331XAL	(5)	900
	470	6.3	7.7	D8	600	0.16	0.19	EEEFTA471XAL	(5)	900
	1000	8.0	10.2	F	850	0.08	0.19	EEEFT1A102AL	(6)	500
	1500	10.0	10.2	G	1190	0.06	0.19	EEEFT1A152AL	(6)	500
16	150	6.3	5.8	D	300	0.26	0.16	EEEFT1C151AL	(5)	1000
	220	6.3	5.8	D	300	0.26	0.16	EEEFT1C221AL	(5)	1000
	330	6.3	7.7	D8	600	0.16	0.16	EEEFTC331XAL	(5)	900
	680	8.0	10.2	F	850	0.08	0.16	EEEFT1C681AL	(6)	500
	820	8.0	10.2	F	850	0.08	0.16	EEEFT1C821UL	(6)	500
	1000	10.0	10.2	G	1190	0.06	0.16	EEEFT1C102AL	(6)	500
	1200	10.0	10.2	G	1190	0.06	0.16	EEEFT1C122UL	(6)	500
25	100	6.3	5.8	D	300	0.26	0.14	EEEFT1E101AL	(5)	1000
	150	6.3	7.7	D8	600	0.16	0.14	EEEFTE151XAL	(5)	900
	220	6.3	7.7	D8	600	0.16	0.14	EEEFTE221XAL	(5)	900
	470	8.0	10.2	F	850	0.08	0.14	EEEFT1E471AL	(6)	500
	560	8.0	10.2	F	850	0.08	0.14	EEEFT1E561UL	(6)	500
	820	10.0	10.2	G	1190	0.06	0.14	EEEFT1E821AL	(6)	500
	1000	10.0	10.2	G	1190	0.06	0.14	EEEFT1E102UL	(6)	500
35	68	6.3	5.8	D	300	0.26	0.12	EEEFT1V680AL	(5)	1000
	100	6.3	5.8	D	300	0.26	0.12	EEEFT1V101AL	(5)	1000
	150	6.3	7.7	D8	600	0.16	0.12	EEEFV151XAL	(5)	900
	330	8.0	10.2	F	850	0.08	0.12	EEEFT1V331AL	(6)	500
	390	8.0	10.2	F	850	0.08	0.12	EEEFT1V391UL	(6)	500
	560	10.0	10.2	G	1190	0.06	0.12	EEEFT1V561AL	(6)	500
	680	10.0	10.2	G	1190	0.06	0.12	EEEFT1V681UL	(6)	500
50	47	6.3	5.8	D	195	0.68	0.10	EEEFT1H470AL	(5)	1000
	100	6.3	7.7	D8	350	0.34	0.10	EEEFTH101XAL	(5)	900
	220	8.0	10.2	F	670	0.08	0.10	EEEFT1H221AL	(6)	500
	330	10.0	10.2	G	900	0.12	0.10	EEEFT1H331AL	(6)	500

*1: Ripple current (100 kHz / +105 °C)

*2: ESR (100 kHz / +20 °C)

*3: tan δ (120 Hz / +20 °C)

- If Part number exceeds 12 digits, voltage code is abbreviated as follows; 0J → J, 1A → A, 1C → C, 1E → E, 1V → V, 1H → H
- Please refer to the page of "Reflow Profile" and "The Taping Dimensions".

Surface Mount Type

FP series **V** type

High temperature Lead-Free reflow (suffix : A*)



Features

- Endurance : 105 °C 2000 h
- Low ESR (30 % to 50 % less than FK series)
- Vibration-proof product (30G guaranteed) is available upon request (ø6.3 ≤)
- AEC-Q200 compliant
- RoHS compliant

Specifications

Category temp. range	-55 °C to +105 °C							
Rated voltage range	6.3 V to 50 V							
Capacitance range	10 µF to 1800 µF							
Capacitance tolerance	±20 % (120 Hz / +20 °C)							
Leakage current	I ≤ 0.01 CV or 3 (µA) After 2 minutes (Whichever is greater)							
Dissipation factor (tan δ)	Please see the attached characteristics list							
Characteristics at low temperature	Rated voltage (V)	6.3	10	16	25	35	50	(Impedance ratio at 120 Hz)
	Z (-25 °C) / Z (+20 °C)	2	2	2	2	2	2	
	Z (-40 °C) / Z (+20 °C)	3	3	3	3	3	3	
	Z (-55 °C) / Z (+20 °C)	4	4	4	3	3	3	
Endurance	After applying rated working voltage for 2000 hours at +105 °C ± 2 °C and then being stabilized at +20 °C, capacitors shall meet the following limits.							
	Capacitance change	Within ±30 % of the initial value						
	Dissipation factor (tan δ)	≤ 200 % of the initial limit						
	Leakage current	Within the initial limit						
Shelf life	After storage for 1000 hours at +105 °C ± 2 °C with no voltage applied and then being stabilized at +20 °C, capacitors shall meet the limits specified in endurance. (With voltage treatment)							
	After reflow soldering and then being stabilized at +20 °C, capacitors shall meet the following limits.							
Resistance to soldering heat	After reflow soldering and then being stabilized at +20 °C, capacitors shall meet the following limits.							
	Capacitance change	Within ±10 % of the initial value						
	Dissipation factor (tan δ)	Within the initial limit						
	Leakage current	Within the initial limit						

Frequency correction factor for ripple current

Cap. (µF) \ Freq. (Hz)	120	1 k	10 k	100 k to
10 to 470	0.65	0.85	0.95	1.00
560 to 1800	0.70	0.90	0.95	1.00

Marking

Example : 6.3 V 22 µF

Marking color : BLACK

Negative polarity marking (-)

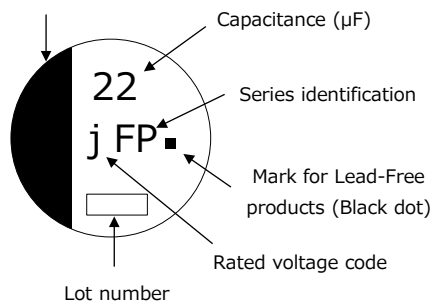

R.voltage code

Unit : V

j	6.3	E	25
A	10	V	35
C	16	H	50

Dimensions

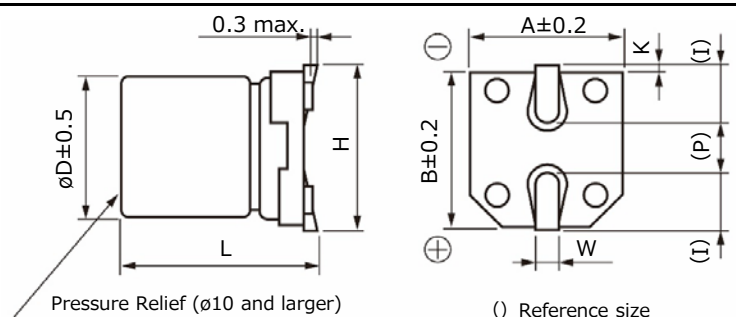

Size code	øD	L	A, B	H	I	W	P	K
B	4.0	5.8±0.3	4.3	5.5 max.	1.8	0.65±0.1	1.0	0.35 ^{+0.15} _{-0.20}
C	5.0	5.8±0.3	5.3	6.5 max.	2.2	0.65±0.1	1.5	0.35 ^{+0.15} _{-0.20}
D	6.3	5.8±0.3	6.6	7.8 max.	2.6	0.65±0.1	1.8	0.35 ^{+0.15} _{-0.20}
D8	6.3	7.7±0.3	6.6	7.8 max.	2.6	0.65±0.1	1.8	0.35 ^{+0.15} _{-0.20}
E	8.0	6.2±0.3	8.3	9.5 max.	3.4	0.65±0.1	2.2	0.35 ^{+0.15} _{-0.20}
F	8.0	10.2±0.3	8.3	10.0 max.	3.4	0.90±0.2	3.1	0.70±0.2
G	10.0	10.2±0.3	10.3	12.0 max.	3.5	0.90±0.2	4.6	0.70±0.2

*The dimensions of the vibration-proof products, please refer to the page of the mounting specification.

Characteristics list

Endurance : 105 °C 2000 h

Rated voltage (V)	Capacitance (±20 %) (μF)	Case size (mm)			Size code*1	Specification			Part No.		Reflow	Min. Packaging Q'ty (pcs)
		øD	L			Ripple current*2 (mA rms)	ESR*3 (Ω)	tan δ*4	Standard Product	Vibration-proof product		Taping
			Standard	Vibration-proof								
6.3	22	4.0	5.8	—	B	160	0.85	0.26	EEEEFP0J220AR	—	(5)	2000
	47	4.0	5.8	—	(B)	160	0.85	0.26	EEEEFPJ470UAR	—	(5)	2000
		5.0	5.8	—	C	240	0.36	0.26	EEEEFP0J470AR	—	(5)	1000
	100	5.0	5.8	—	(C)	240	0.36	0.26	EEEEFPJ101UAR	—	(5)	1000
		6.3	5.8	6.1	D	300	0.26	0.26	EEEEFP0J101AP	EEEEFP0J101AV	(5)	1000
	220	6.3	5.8	6.1	D	300	0.26	0.26	EEEEFP0J221AP	EEEEFP0J221AV	(5)	1000
		330	6.3	7.7	8.0	D8	600	0.16	0.26	EEEEFPJ331XAP	EEEEFPJ331XAV	(5)
	8.0		6.2	6.5	E	500	0.18	0.26	EEEEFP0J331AP	EEEEFP0J331AV	(6)	1000
		470	8.0	10.2	10.5	F	850	0.08	0.26	EEEEFP0J471AP	EEEEFP0J471AV	(6)
	1000	8.0	10.2	10.5	F	850	0.08	0.26	EEEEFP0J102AP	EEEEFP0J102AV	(6)	500
1500	10.0	10.2	10.5	G	1190	0.06	0.26	EEEEFP0J152AP	EEEEFP0J152AV	(6)	500	
1800	10.0	10.2	10.5	(G)	850	0.08	0.26	EEEEFPJ182UAP	EEEEFPJ182UAV	(6)	500	
10	22	4.0	5.8	—	B	160	0.85	0.19	EEEEFP1A220AR	—	(5)	2000
	33	4.0	5.8	—	(B)	160	0.85	0.19	EEEEFPA330UAR	—	(5)	2000
		5.0	5.8	—	C	240	0.36	0.19	EEEEFP1A330AR	—	(5)	1000
	150	6.3	5.8	6.1	D	300	0.26	0.19	EEEEFP1A151AP	EEEEFP1A151AV	(5)	1000
		220	6.3	7.7	8.0	D8	600	0.16	0.19	EEEEFPA221XAP	EEEEFPA221XAV	(5)
	8.0		6.2	6.5	E	500	0.18	0.19	EEEEFP1A221AP	EEEEFP1A221AV	(6)	1000
		330	8.0	10.2	10.5	F	850	0.08	0.19	EEEEFP1A331AP	EEEEFP1A331AV	(6)
	470	8.0	10.2	10.5	F	850	0.08	0.19	EEEEFP1A471AP	EEEEFP1A471AV	(6)	500
	680	8.0	10.2	10.5	F	850	0.08	0.19	EEEEFP1A681AP	EEEEFP1A681AV	(6)	500
	1000	10.0	10.2	10.5	G	1190	0.06	0.19	EEEEFP1A102AP	EEEEFP1A102AV	(6)	500
1200	10.0	10.2	10.5	(G)	850	0.08	0.19	EEEEFPA122UAP	EEEEFPA122UAV	(6)	500	
16	10	4.0	5.8	—	B	160	0.85	0.16	EEEEFP1C100AR	—	(5)	2000
	22	4.0	5.8	—	(B)	160	0.85	0.16	EEEEFPC220UAR	—	(5)	2000
		5.0	5.8	—	C	240	0.36	0.16	EEEEFP1C220AR	—	(5)	1000
	47	5.0	5.8	—	(C)	240	0.36	0.16	EEEEFPC470UAR	—	(5)	1000
		6.3	5.8	6.1	D	300	0.26	0.16	EEEEFP1C470AP	EEEEFP1C470AV	(5)	1000
	68	6.3	5.8	6.1	D	300	0.26	0.16	EEEEFP1C680AP	EEEEFP1C680AV	(5)	1000
	100	6.3	5.8	6.1	D	300	0.26	0.16	EEEEFP1C101AP	EEEEFP1C101AV	(5)	1000
		6.3	7.7	8.0	D8	600	0.16	0.16	EEEEFPC101XAP	EEEEFPC101XAV	(5)	900
	150	6.3	7.7	8.0	D8	600	0.16	0.16	EEEEFPC151XAP	EEEEFPC151XAV	(5)	900
		220	6.3	7.7	8.0	D8	600	0.16	0.16	EEEEFPC221XAP	EEEEFPC221XAV	(5)
	8.0		6.2	6.5	E	500	0.18	0.16	EEEEFP1C221AP	EEEEFP1C221AV	(6)	1000
		330	8.0	10.2	10.5	F	850	0.08	0.16	EEEEFP1C331AP	EEEEFP1C331AV	(6)
	470	8.0	10.2	10.5	F	850	0.08	0.16	EEEEFP1C471AP	EEEEFP1C471AV	(6)	500
	680	10.0	10.2	10.5	G	1190	0.06	0.16	EEEEFP1C681AP	EEEEFP1C681AV	(6)	500
820	10.0	10.2	10.5	(G)	850	0.08	0.16	EEEEFPC821UAP	EEEEFPC821UAV	(6)	500	
25	10	4.0	5.8	—	B	160	0.85	0.14	EEEEFP1E100AR	—	(5)	2000
	22	5.0	5.8	—	C	240	0.36	0.14	EEEEFP1E220AR	—	(5)	1000
		33	5.0	5.8	—	(C)	240	0.36	0.14	EEEEFPE330UAR	—	(5)
	6.3		5.8	6.1	D	300	0.26	0.14	EEEEFP1E330AP	EEEEFP1E330AV	(5)	1000
		47	6.3	5.8	6.1	D	300	0.26	0.14	EEEEFP1E470AP	EEEEFP1E470AV	(5)
	68	6.3	5.8	6.1	D	300	0.26	0.14	EEEEFP1E680AP	EEEEFP1E680AV	(5)	1000
		8.0	6.3	7.7	8.0	D8	600	0.16	0.14	EEEEFPE101XAP	EEEEFPE101XAV	(5)
	8.0		6.2	6.5	E	500	0.18	0.14	EEEEFP1E101AP	EEEEFP1E101AV	(6)	1000
		150	8.0	10.2	10.5	F	850	0.08	0.14	EEEEFP1E151AP	EEEEFP1E151AV	(6)
	220	8.0	10.2	10.5	F	850	0.08	0.14	EEEEFP1E221AP	EEEEFP1E221AV	(6)	500
	330	8.0	10.2	10.5	F	850	0.08	0.14	EEEEFP1E331AP	EEEEFP1E331AV	(6)	500
	470	10.0	10.2	10.5	G	1190	0.06	0.14	EEEEFP1E471AP	EEEEFP1E471AV	(6)	500
	560	10.0	10.2	10.5	(G)	850	0.08	0.14	EEEEFPE561UAP	EEEEFPE561UAV	(6)	500

*1: Size code(): Miniaturization product

*2: Ripple current (100 kHz / +105 °C)

*3: ESR (100 kHz / +20 °C)

*4: tan δ (120 Hz / +20 °C)

• If Part number exceeds 12 digits, voltage code is abbreviated as follows; 0J → J, 1A → A, 1C → C, 1E → E

• Please refer to the page of "Reflow Profile" and "The Taping Dimensions".

Characteristics list

Endurance : 105 °C 2000 h

Rated voltage (V)	Capacitance (±20 %) (μF)	Case size (mm)			Size code*1	Specification			Part No.		Reflow	Min. Packaging Q'ty (pcs)
		øD	L			Ripple current*2 (mA rms)	ESR*3 (Ω)	tan δ*4	Standard Product	Vibration-proof product		Taping
			Standard	Vibration-proof								
35	10	4.0	5.8	—	(B)	160	0.85	0.12	EEEEFPV100UAR	—	(5)	2000
	22	5.0	5.8	—	C	240	0.36	0.12	EEEEFP1V220AR	—	(5)	1000
	33	6.3	5.8	6.1	D	300	0.26	0.12	EEEEFP1V330AP	EEEEFP1V330AV	(5)	1000
	47	6.3	5.8	6.1	D	300	0.26	0.12	EEEEFP1V470AP	EEEEFP1V470AV	(5)	1000
	68	6.3	7.7	8.0	D8	600	0.16	0.12	EEEEFPV680XAP	EEEEFPV680XAV	(5)	900
	100	6.3	7.7	8.0	D8	600	0.16	0.12	EEEEFPV101XAP	EEEEFPV101XAV	(5)	900
		8.0	10.2	10.5	F	850	0.08	0.12	EEEEFP1V101AP	EEEEFP1V101AV	(6)	500
	150	8.0	10.2	10.5	F	850	0.08	0.12	EEEEFP1V151AP	EEEEFP1V151AV	(6)	500
	220	8.0	10.2	10.5	F	850	0.08	0.12	EEEEFP1V221AP	EEEEFP1V221AV	(6)	500
	330	10.0	10.2	10.5	G	1190	0.06	0.12	EEEEFP1V331AP	EEEEFP1V331AV	(6)	500
390	10.0	10.2	10.5	(G)	850	0.08	0.12	EEEEFPV391UAP	EEEEFPV391UAV	(6)	500	
50	100	8.0	10.2	10.5	F	670	0.18	0.10	EEEEFP1H101AP	EEEEFP1H101AV	(6)	500
	220	10.0	10.2	10.5	G	900	0.12	0.10	EEEEFP1H221AP	EEEEFP1H221AV	(6)	500

*1: Size code(): Miniaturization product

*2: Ripple current (100 kHz / +105 °C)

*3: ESR (100 kHz / +20 °C)

*4: tan δ (120 Hz / +20 °C)

• If Part number exceeds 12 digits, voltage code is abbreviated as follows; 1V → V

• Please refer to the page of "Reflow Profile" and "The Taping Dimensions".

Surface Mount Type

Halogen-free FP series V type

High temperature Lead-Free reflow (suffix : A*)



Features

- Endurance : 105 °C 2000 h
- Low ESR (30 % to 50 % less than FK series)
- AEC-Q200 compliant
- RoHS compliant

Country of origin

- Malaysia

Specifications

Category temp. range	-55 °C to +105 °C								
Rated voltage range	6.3 V to 50 V								
Capacitance range	33 μF to 1800 μF								
Capacitance tolerance	±20 % (120 Hz / +20 °C)								
Leakage current	I ≤ 0.01 CV or 3 (μA) After 2 minutes (Whichever is greater)								
Dissipation factor (tan δ)	Please see the attached characteristics list								
Characteristics at low temperature	Rated voltage (V)	6.3	10	16	25	35	50	(Impedance ratio at 120 Hz)	
	Z (-25 °C) / Z (+20 °C)	2	2	2	2	2	2		
	Z (-40 °C) / Z (+20 °C)	3	3	3	3	3	3		
Endurance	After applying rated working voltage for 2000 hours at +105 °C ± 2 °C and then being stabilized at +20 °C, capacitors shall meet the following limits.								
	Capacitance change	Within ±30 % of the initial value							
	Dissipation factor (tan δ)	≤ 200 % of the initial limit							
Shelf life	After storage for 1000 hours at +105 °C ± 2 °C with no voltage applied and then being stabilized at +20 °C, capacitors shall meet the limits specified in endurance. (With voltage treatment)								
	After reflow soldering and then being stabilized at +20 °C, capacitors shall meet the following limits.								
Resistance to soldering heat	After reflow soldering and then being stabilized at +20 °C, capacitors shall meet the following limits.								
	Capacitance change	Within ±10 % of the initial value							
	Dissipation factor (tan δ)	Within the initial limit							
		Leakage current							Within the initial limit

Frequency correction factor for ripple current

Cap. (μF) \ Freq. (Hz)	120	1 k	10 k	100 k to
33 to 470	0.65	0.85	0.95	1.00
560 to 1800	0.70	0.90	0.95	1.00

Marking

Example : 6.3 V 100 μF
Marking color : BLACK

Negative polarity marking (-)

Capacitance (μF)

Series identification

Mark for Lead-Free products (Black dot)

Rated voltage code

Lot number

R.voltage code		Unit : V	
j	6.3	E	25
A	10	V	35
C	16	H	50

Dimensions

0.3 max.

øD±0.5

L

H

A±0.2

I

W

P

K

(I) Reference size

Pressure Relief (ø10 and larger)

Unit : mm

Size code	øD	L	A, B	H	I	W	P	K
D	6.3	5.8±0.3	6.6	7.8 max.	2.6	0.65±0.1	1.8	0.35 ^{+0.15} _{-0.20}
D8	6.3	7.7±0.3	6.6	7.8 max.	2.6	0.65±0.1	1.8	0.35 ^{+0.15} _{-0.20}
E	8.0	6.2±0.3	8.3	9.5 max.	3.4	0.65±0.1	2.2	0.35 ^{+0.15} _{-0.20}
F	8.0	10.2±0.3	8.3	10.0 max.	3.4	0.90±0.2	3.1	0.70±0.2
G	10.0	10.2±0.3	10.3	12.0 max.	3.5	0.90±0.2	4.6	0.70±0.2

Characteristics list

Endurance : 105 °C 2000 h

Rated voltage (V)	Capacitance (±20 %) (μF)	Case size (mm)		Size code*1	Specification			Part number	Reflow	Min. Packaging Q'ty (pcs)
		øD	L		Ripple current*2 (mA rms)	ESR*3 (Ω)	tanδ*4			Taping
6.3	100	6.3	5.8	D	300	0.26	0.26	EEEEFP0J101AL	(5)	1000
	220	6.3	5.8	D	300	0.26	0.26	EEEEFP0J221AL	(5)	1000
	330	6.3	7.7	D8	600	0.16	0.26	EEEEFPJ331XAL	(5)	900
		8.0	6.2	E	500	0.18	0.26	EEEEFP0J331AL	(6)	1000
	470	8.0	10.2	F	850	0.08	0.26	EEEEFP0J471AL	(6)	500
	1000	8.0	10.2	F	850	0.08	0.26	EEEEFP0J102AL	(6)	500
	1500	10.0	10.2	G	1190	0.06	0.26	EEEEFP0J152AL	(6)	500
1800	10.0	10.2	(G)	850	0.08	0.26	EEEEFPJ182UAL	(6)	500	
10	150	6.3	5.8	D	300	0.26	0.19	EEEEFP1A151AL	(5)	1000
	220	6.3	7.7	D8	600	0.16	0.19	EEEFPA221XAL	(5)	900
		8.0	6.2	E	500	0.18	0.19	EEEEFP1A221AL	(6)	1000
	330	8.0	10.2	F	850	0.08	0.19	EEEEFP1A331AL	(6)	500
	470	8.0	10.2	F	850	0.08	0.19	EEEEFP1A471AL	(6)	500
	680	8.0	10.2	F	850	0.08	0.19	EEEFPA681AL	(6)	500
	1000	10.0	10.2	G	1190	0.06	0.19	EEEEFP1A102AL	(6)	500
1200	10.0	10.2	(G)	850	0.08	0.19	EEEFPA122UAL	(6)	500	
16	47	6.3	5.8	D	300	0.26	0.16	EEEEFP1C470AL	(5)	1000
	68	6.3	5.8	D	300	0.26	0.16	EEEEFP1C680AL	(5)	1000
	100	6.3	5.8	D	300	0.26	0.16	EEEEFP1C101AL	(5)	1000
		6.3	7.7	D8	600	0.16	0.16	EEEFPC101XAL	(5)	900
	150	6.3	7.7	D8	600	0.16	0.16	EEEFPC151XAL	(5)	900
	220	6.3	7.7	D8	600	0.16	0.16	EEEFPC221XAL	(5)	900
		8.0	6.2	E	500	0.18	0.16	EEEEFP1C221AL	(6)	1000
	330	8.0	10.2	F	850	0.08	0.16	EEEEFP1C331AL	(6)	500
	470	8.0	10.2	F	850	0.08	0.16	EEEEFP1C471AL	(6)	500
	680	10.0	10.2	G	1190	0.06	0.16	EEEEFP1C681AL	(6)	500
820	10.0	10.2	(G)	850	0.08	0.16	EEEFPC821UAL	(6)	500	
25	33	6.3	5.8	D	300	0.26	0.14	EEEEFP1E330AL	(5)	1000
	47	6.3	5.8	D	300	0.26	0.14	EEEEFP1E470AL	(5)	1000
	68	6.3	5.8	D	300	0.26	0.14	EEEEFP1E680AL	(5)	1000
	100	6.3	7.7	D8	600	0.16	0.14	EEEFPE101XAL	(5)	900
		8.0	6.2	E	500	0.18	0.14	EEEEFP1E101AL	(6)	1000
	150	8.0	10.2	F	850	0.08	0.14	EEEEFP1E151AL	(6)	500
	220	8.0	10.2	F	850	0.08	0.14	EEEEFP1E221AL	(6)	500
	330	8.0	10.2	F	850	0.08	0.14	EEEEFP1E331AL	(6)	500
	470	10.0	10.2	G	1190	0.06	0.14	EEEEFP1E471AL	(6)	500
560	10.0	10.2	(G)	850	0.08	0.14	EEEFPE561UAL	(6)	500	
35	33	6.3	5.8	D	300	0.26	0.12	EEEEFP1V330AL	(5)	1000
	47	6.3	5.8	D	300	0.26	0.12	EEEEFP1V470AL	(5)	1000
	68	6.3	7.7	D8	600	0.16	0.12	EEEFV680XAL	(5)	900
	100	6.3	7.7	D8	600	0.16	0.12	EEEFV101XAL	(5)	900
		8.0	10.2	F	850	0.08	0.12	EEEEFP1V101AL	(6)	500
	150	8.0	10.2	F	850	0.08	0.12	EEEEFP1V151AL	(6)	500
	220	8.0	10.2	F	850	0.08	0.12	EEEEFP1V221AL	(6)	500
	330	10.0	10.2	G	1190	0.06	0.12	EEEEFP1V331AL	(6)	500
	390	10.0	10.2	(G)	850	0.08	0.12	EEEFV391UAL	(6)	500
50	100	8.0	10.2	F	670	0.18	0.1	EEEEFP1H101AL	(6)	500
	220	10.0	10.2	G	900	0.12	0.10	EEEEFP1H221AL	(6)	500

*1: Size code(): Miniaturization product

*2: Ripple current (100 kHz / +105 °C)

*3: ESR (100 kHz / +20 °C)

*4: tan δ (120 Hz / +20 °C)

· If Part number exceeds 12 digits, voltage code is abbreviated as follows; 0J → J, 1A → A, 1C → C, 1E → E, 1V → V

· Please refer to the page of "Reflow Profile" and "The Taping Dimensions".

Surface Mount Type

TG series

V type



Features

- Endurance : 125 °C 1000 h to 2000 h
- Miniaturization (40 % less than TA series)
- Low ESR (Low temp)
- Vibration-proof product (30G guaranteed) is available upon request
- AEC-Q200 compliant
- RoHS compliant (Part No. ø8 to ø10 : EEE*, ø12.5 to ø18 : EEV*)

Specifications

Category temp. range	-40 °C to +125 °C									
Rated voltage range	10 V to 100 V									
Capacitance range	10 µF to 4700 µF									
Capacitance tolerance	±20 % (120 Hz / +20 °C)									
Leakage current	I ≤ 0.01 CV (µA) After 2 minutes									
Dissipation factor (tan δ)	Please see the attached characteristics list									
Characteristics at low temperature	Rated voltage (V)	10	16	25	35	50	63	80	100	(Impedance ratio at 120 Hz)
	Z (-25 °C) / Z (+20 °C)	3	2	2	2	2	2	2	2	
	Z (-40 °C) / Z (+20 °C)	6	4	4	3	3	3	3	3	
Endurance	After applying rated working voltage for 1000 hours (ø8×6.2), 2000 hours (ø8×10.2 ≤) at +125 °C ± 2 °C and then being stabilized at +20 °C, capacitors shall meet the following limits.									
	Capacitance change	Within ±30 % of the initial value (code U : ±35 %)								
	Dissipation factor (tan δ)	≤ 300 % of the initial limit (code U : ±350 %)								
Shelf life	After storage for 1000 hours at +125 °C ± 2 °C with no voltage applied and then being stabilized at +20 °C, capacitors shall meet the limits specified in endurance. (With voltage treatment)									
Resistance to soldering heat	After reflow soldering and then being stabilized at +20 °C, capacitors shall meet the following limits.									
	Capacitance change	Within ±10 % of the initial value								
	Dissipation factor (tan δ)	Within the initial limit								
	Leakage current	Within the initial limit								

Frequency correction factor for ripple current

Frequency (Hz)	120	1 k	10 k	100 k to
Correction factor	0.65	0.85	0.95	1.00

Marking

Example : 10 V 100 µF Marking color : BLACK
Lead-Free (≤ ø10)

Capacitance (µF)
 Negative polarity marking (-)
 Series identification
 Mark for Lead-Free products (Black dot)
 Lot number
 Rated voltage code

Example: 10 V 1000 µF Marking color : BLACK
Lead-Free (≥ ø12.5)

Capacitance (µF)
 Negative polarity marking (-)
 Series identification
 Lot number
 Rated voltage code

R.voltage code		Unit : V	
A	10	H	50
C	16	J	63
E	25	K	80
V	35	2A	100

Dimensions

0.3 max.
 øD±0.5
 L
 H
 Pressure Relief (ø10 and larger)
 A±0.2
 W
 P
 I
 K
 (I) Reference size

Unit : mm								
Size code	øD	L	A, B	H	I	W	P	K
E	8.0	6.2±0.3	8.3	9.5 max.	3.4	0.65±0.1	2.2	0.35 ^{+0.15} _{-0.20}
F	8.0	10.2±0.3	8.3	10.0 max.	3.4	0.90±0.2	3.1	0.70±0.2
G	10.0	10.2±0.3	10.3	12.0 max.	3.5	0.90±0.2	4.6	0.70±0.2
H13	12.5	13.5±0.5	13.5	15.0 max.	4.7	0.90±0.3	4.4	0.70±0.3
J16	16.0	16.5±0.5	17.0	19.0 max.	5.5	1.20±0.3	6.7	0.70±0.3
K16	18.0	16.5±0.5	19.0	21.0 max.	6.7	1.20±0.3	6.7	0.70±0.3

*The dimensions of the vibration-proof products, please refer to the page of the mounting specification.

Characteristics list

Endurance : 125 °C 1000 h (ø8×10.2 ≤ : 2000 h)

Rated voltage (V)	Capacitance (±20 %) (µF)	Case size (mm)		Size code*1	Specification			Part No.	Reflow	Min. Packaging Q'ty (pcs)
		øD	L		Ripple current*2 (mA rms)	ESR*3 (Ω)	tanδ*4			Taping
10	100	8.0	6.2	E	100	1.00	0.30	EEETG1A101P	(2)	1000
	220	8.0	6.2	(E)	100	1.00	0.30	EEETG1A221UP	(2)	1000
		8.0	10.2	F	197	0.50	0.30	EEETG1A221P	(2)	500
	330	8.0	10.2	(F)	197	0.50	0.30	EEETG1A331UP	(2)	500
		10.0	10.2	G	270	0.30	0.30	EEETG1A331P	(2)	500
	470	10.0	10.2	(G)	270	0.30	0.30	EEETG1A471UP	(2)	500
	1000	12.5	13.5	H13	800	0.12	0.30	EEVTG1A102Q	(3)	200
	1500	12.5	13.5	(H13)	800	0.12	0.30	EEVTG1A152UQ	(3)	200
	2200	16.0	16.5	J16	1100	0.08	0.32	EEVTG1A222M	(3)	125
		16.0	16.5	(J16)	1100	0.08	0.34	EEVTG1A332UM	(3)	125
3300	18.0	16.5	K16	1300	0.075	0.34	EEVTG1A332M	(3)	125	
4700	18.0	16.5	K16	1300	0.075	0.36	EEVTG1A472M	(3)	125	
16	100	8.0	10.2	F	197	0.50	0.23	EEETG1C101P	(2)	500
	220	8.0	10.2	(F)	197	0.50	0.23	EEETG1C221UP	(2)	500
		10.0	10.2	G	270	0.30	0.23	EEETG1C221P	(2)	500
	330	10.0	10.2	(G)	270	0.30	0.23	EEETG1C331UP	(2)	500
		12.5	13.5	H13	800	0.12	0.23	EEVTG1C331Q	(3)	200
	470	12.5	13.5	H13	800	0.12	0.23	EEVTG1C471Q	(3)	200
	680	12.5	13.5	H13	800	0.12	0.23	EEVTG1C681Q	(3)	200
	1000	12.5	13.5	(H13)	800	0.12	0.23	EEVTG1C102UQ	(3)	200
		16.0	16.5	J16	1100	0.08	0.23	EEVTG1C102M	(3)	125
	2200	16.0	16.5	(J16)	1100	0.08	0.25	EEVTG1C222UM	(3)	125
18.0		16.5	K16	1300	0.075	0.25	EEVTG1C222M	(3)	125	
3300	18.0	16.5	K16	1300	0.075	0.27	EEVTG1C332M	(3)	125	
25	47	8.0	6.2	E	100	1.00	0.18	EEETG1E470P	(2)	1000
	100	8.0	6.2	(E)	100	1.00	0.18	EEETG1E101UP	(2)	1000
		8.0	10.2	F	197	0.50	0.18	EEETG1E101P	(2)	500
	220	8.0	10.2	(F)	197	0.50	0.18	EEETG1E221UP	(2)	500
		10.0	10.2	G	270	0.30	0.18	EEETG1E221P	(2)	500
	330	10.0	10.2	(G)	270	0.30	0.18	EEETG1E331UP	(2)	500
		12.5	13.5	H13	800	0.12	0.18	EEVTG1E331Q	(3)	200
	470	12.5	13.5	H13	800	0.12	0.18	EEVTG1E471Q	(3)	200
	680	12.5	13.5	(H13)	800	0.12	0.18	EEVTG1E681UQ	(3)	200
		16.0	16.5	J16	1100	0.08	0.18	EEVTG1E681M	(3)	125
1000	16.0	16.5	(J16)	1100	0.08	0.18	EEVTG1E102UM	(3)	125	
	18.0	16.5	K16	1300	0.075	0.18	EEVTG1E102M	(3)	125	
2200	18.0	16.5	K16	1300	0.075	0.20	EEVTG1E222M	(3)	125	
35	33	8.0	6.2	E	100	1.00	0.16	EEETG1V330P	(2)	1000
	47	8.0	6.2	(E)	100	1.00	0.16	EEETG1V470UP	(2)	1000
		8.0	10.2	F	197	0.50	0.16	EEETG1V470P	(2)	500
	100	8.0	10.2	(F)	197	0.50	0.16	EEETG1V101UP	(2)	500
		10.0	10.2	G	270	0.30	0.16	EEETG1V101P	(2)	500
	220	10.0	10.2	(G)	270	0.30	0.16	EEETG1V221UP	(2)	500
	330	12.5	13.5	H13	800	0.12	0.16	EEVTG1V331Q	(3)	200
		12.5	13.5	(H13)	800	0.12	0.16	EEVTG1V471UQ	(3)	200
	470	16.0	16.5	J16	1100	0.08	0.16	EEVTG1V471M	(3)	125
		16.0	16.5	(J16)	1100	0.08	0.16	EEVTG1V681UM	(3)	125
680	18.0	16.5	K16	1300	0.075	0.16	EEVTG1V681M	(3)	125	
1000	18.0	16.5	K16	1300	0.075	0.16	EEVTG1V102M	(3)	125	

*1: Size code(): Miniaturization product

*2: Ripple current (100 kHz / +125 °C)

*3: ESR (100 kHz / +20 °C)

*4: tan δ (120 Hz / +20 °C)

• Please refer to the page of "Reflow Profile" and "The Taping Dimensions".

• When requesting vibration-proof product, please put the last "V" instead to "P", "Q", or "M"

Characteristics list

Endurance : 125 °C 1000 h ($\phi 8 \times 10.2 \leq$: 2000 h)

Rated voltage (V)	Capacitance ($\pm 20\%$) (μF)	Case size (mm)		Size code*1	Specification			Part No.	Reflow	Min. Packaging Q'ty (pcs)
		ϕD	L		Ripple current*2 (mA rms)	ESR*3 (Ω)	$\tan\delta$ *4			Taping
50	10	8.0	6.2	E	80	1.60	0.14	EEETG1H100P	(2)	1000
	22	8.0	6.2	E	80	1.60	0.14	EEETG1H220P	(2)	1000
	33	8.0	6.2	(E)	80	1.60	0.14	EEETG1H330UP	(2)	1000
		8.0	10.2	F	133	0.75	0.14	EEETG1H330P	(2)	500
	47	8.0	10.2	(F)	133	0.75	0.14	EEETG1H470UP	(2)	500
		10.0	10.2	G	221	0.50	0.14	EEETG1H470P	(2)	500
	100	10.0	10.2	(G)	221	0.50	0.14	EEETG1H101UP	(2)	500
	220	12.5	13.5	H13	600	0.23	0.14	EEVTG1H221Q	(3)	200
	330	12.5	13.5	H13	600	0.23	0.14	EEVTG1H331Q	(3)	200
	470	16.0	16.5	J16	900	0.15	0.14	EEVTG1H471M	(3)	125
680	16.0	16.5	(J16)	900	0.15	0.14	EEVTG1H681UM	(3)	125	
	18.0	16.5	K16	950	0.14	0.14	EEVTG1H681M	(3)	125	
	1000	18.0	16.5	K16	950	0.14	0.14	EEVTG1H102M	(3)	125
63	10	8.0	6.2	E	55	2.20	0.12	EEETG1J100P	(2)	1000
	22	8.0	10.2	F	100	1.00	0.12	EEETG1J220P	(2)	500
	33	8.0	10.2	(F)	100	1.00	0.12	EEETG1J330UP	(2)	500
		10.0	10.2	G	150	0.80	0.12	EEETG1J330P	(2)	500
	47	8.0	10.2	(F)	100	1.00	0.12	EEETG1J470UP	(2)	500
		10.0	10.2	G	150	0.80	0.12	EEETG1J470P	(2)	500
	100	10.0	10.2	(G)	150	0.80	0.12	EEETG1J101UP	(2)	500
		12.5	13.5	H13	350	0.26	0.12	EEVTG1J101Q	(3)	200
	220	12.5	13.5	H13	350	0.26	0.12	EEVTG1J221Q	(3)	200
	330	16.0	16.5	J16	500	0.18	0.12	EEVTG1J331M	(3)	125
470	16.0	16.5	J16	500	0.18	0.12	EEVTG1J471M	(3)	125	
80	10	8.0	10.2	F	70	1.30	0.12	EEETG1K100P	(2)	500
	22	8.0	10.2	(F)	70	1.30	0.12	EEETG1K220UP	(2)	500
		10.0	10.2	G	90	1.00	0.12	EEETG1K220P	(2)	500
	33	8.0	10.2	(F)	70	1.30	0.12	EEETG1K330UP	(2)	500
		10.0	10.2	G	90	1.00	0.12	EEETG1K330P	(2)	500
	47	10.0	10.2	(G)	90	1.00	0.12	EEETG1K470UP	(2)	500
		12.5	13.5	H13	250	0.42	0.12	EEVTG1K470Q	(3)	200
	100	12.5	13.5	(H13)	250	0.42	0.12	EEVTG1K101UQ	(3)	200
		16.0	16.5	J16	350	0.30	0.12	EEVTG1K101M	(3)	125
	220	16.0	16.5	(J16)	350	0.30	0.12	EEVTG1K221UM	(3)	125
18.0		16.5	K16	400	0.28	0.12	EEVTG1K221M	(3)	125	
330	16.0	16.5	(J16)	350	0.30	0.12	EEVTG1K331UM	(3)	125	
	18.0	16.5	K16	400	0.28	0.12	EEVTG1K331M	(3)	125	
470	18.0	16.5	K16	400	0.28	0.12	EEVTG1K471M	(3)	125	
100	10	8.0	10.2	F	70	1.30	0.10	EEETG2A100P	(2)	500
	22	8.0	10.2	(F)	70	1.30	0.10	EEETG2A220UP	(2)	500
		10.0	10.2	G	90	1.00	0.10	EEETG2A220P	(2)	500
	33	10.0	10.2	G	90	1.00	0.10	EEETG2A330P	(2)	500
	47	12.5	13.5	H13	250	0.42	0.10	EEVTG2A470Q	(3)	200
	100	16.0	16.5	J16	350	0.30	0.10	EEVTG2A101M	(3)	125
	220	18.0	16.5	K16	400	0.28	0.10	EEVTG2A221M	(3)	125
330	18	16.5	K16	400	0.28	0.10	EEVTG2A331M	(3)	125	

*1: Size code(): Miniaturization product

*2: Ripple current (100 kHz / +125 °C)

*3: ESR (100 kHz / +20 °C)

*4: $\tan\delta$ (120 Hz / +20 °C)

• Please refer to the page of "Reflow Profile" and "The Taping Dimensions".

• When requesting vibration-proof product, please put the last "V" instead to "P", "Q", or "M"

Surface Mount Type

Medium-size TK series V type

High temperature Lead-Free reflow (suffix : A*)



Features

- Endurance : 125 °C 2000 h
- Vibration-proof product (30G guaranteed) is available upon request
- AEC-Q200 compliant
- RoHS compliant

Specifications

Category temp. range	-40 °C to +125 °C									
Rated voltage range	10 V to 100 V									
Capacitance range	47 µF to 4700 µF									
Capacitance tolerance	±20 % (120 Hz / +20 °C)									
Leakage current	I ≤ 0.01 CV (µA) After 2 minutes									
Dissipation factor (tan δ)	Please see the attached characteristics list									
Characteristics at low temperature	Rated voltage (V)	10	16	25	35	50	63	80	100	(Impedance ratio at 120 Hz)
	Z (-25 °C) / Z (+20 °C)	3	2	2	2	2	2	2	2	
	Z (-40 °C) / Z (+20 °C)	6	4	4	3	3	3	3	3	
Endurance	After applying rated working voltage for 2000 hours at +125 °C ± 2 °C and then being at +20 °C, capacitors shall meet the following limits.									
	Capacitance change	Within ±30 % of the initial value (Miniaturization product : Within ±35 %)								
	Dissipation factor (tan δ)	≤ 300 % of the initial limit (Miniaturization product : Within 350 %)								
	Leakage current	Within the initial limit								
Shelf life	After storage for 1000 hours at +125 °C ± 2 °C with no voltage applied and then being stabilized at +20 °C, capacitors shall meet the limits specified in endurance. (With voltage treatment)									
Resistance to soldering heat	After reflow soldering and then being stabilized at +20 °C, capacitors shall meet the following limits.									
	Capacitance change	Within ±10 % of the initial value								
	Dissipation factor (tan δ)	Within the initial limit								
	Leakage current	Within the initial limit								

Frequency correction factor for ripple current

Frequency (Hz)	120	1 k	10 k	100 k to
Correction factor	0.75	0.9	0.95	1.00

Marking

Example : 10 V 1000 µF
Marking color : BLACK

Negative polarity marking (-)

Capacitance (µF)

Series identification

Mark for Lead-Free products (Black dot)

Rated voltage code

Lot number

R.voltage code		Unit : V	
A	10	H	50
C	16	J	63
E	25	K	80
V	35	2A	100

Dimensions

() Reference size

Size code	øD	L	A, B	H	I	W	P	K
H13	12.5	13.5±0.5	13.5	15.0 max.	4.7	0.90±0.3	4.4	0.70±0.3
J16	16.0	16.5±0.5	17.0	19.0 max.	5.5	1.20±0.3	6.7	0.70±0.3
K16	18.0	16.5±0.5	19.0	21.0 max.	6.7	1.20±0.3	6.7	0.70±0.3

Unit : mm

*The dimensions of the vibration-proof products, please refer to the page of the mounting specification.

Characteristics list

Endurance : 125 °C 2000 h

Rated voltage (V)	Capacitance (±20 %) (μF)	Case size (mm)		Size code*1	Specification				Part No.	Reflow	Min. Packaging
		øD	L		Ripple current*2 (mA rms)	ESR (100 kHz) (Ω)		tan δ*3			Q'ty (pcs)
						+20 °C	-40 °C				
10	1000	12.5	13.5	H13	800	0.12	1.80	0.30	EEETK1A102AQ	(9)	200
	1500	12.5	13.5	(H13)	800	0.12	1.80	0.30	EEETKA152UAQ	(9)	200
	2200	16.0	16.5	J16	1100	0.08	1.20	0.32	EEETK1A222AM	(9)	125
				(J16)	1100	0.08	1.20	0.34	EEETKA332UAM	(9)	125
	3300	18.0	16.5	K16	1300	0.075	1.10	0.36	EEETK1A332AM	(9)	125
				(K16)	1300	0.075	1.10	0.38	EEETK1A472AM	(9)	125
16	330	12.5	13.5	H13	800	0.12	1.80	0.23	EEETK1C331AQ	(9)	200
	680	12.5	13.5	H13	800	0.12	1.80	0.23	EEETK1C681AQ	(9)	200
	2200	16.0	16.5	J16	1100	0.08	1.20	0.25	EEETK1C102AM	(9)	125
				(J16)	1100	0.08	1.20	0.27	EEETKC222UAM	(9)	125
	3300	18.0	16.5	K16	1300	0.075	1.10	0.29	EEETK1C332AM	(9)	125
				(K16)	1300	0.075	1.10	0.29	EEETK1C332AM	(9)	125
25	330	12.5	13.5	H13	800	0.12	1.80	0.18	EEETK1E331AQ	(9)	200
	470	12.5	13.5	H13	800	0.12	1.80	0.18	EEETK1E471AQ	(9)	200
	680	12.5	13.5	(H13)	800	0.12	1.80	0.18	EEETKE681UAQ	(9)	200
				J16	1100	0.08	1.20	0.18	EEETK1E681AM	(9)	125
	1000	16.0	16.5	(J16)	1100	0.08	1.20	0.18	EEETKE102UAM	(9)	125
				K16	1300	0.075	1.10	0.18	EEETK1E102AM	(9)	125
	2200	18.0	16.5	K16	1300	0.075	1.10	0.20	EEETK1E222AM	(9)	125
(K16)				1300	0.075	1.10	0.20	EEETK1E222AM	(9)	125	
35	330	12.5	13.5	H13	800	0.12	1.80	0.16	EEETK1V331AQ	(9)	200
	J16	1100	0.08	1.20	0.16	EEETK1V471AM	(9)	125			
	680	16.0	16.5	(J16)	1100	0.08	1.20	0.16	EEETKV681UAM	(9)	125
				K16	1300	0.075	1.10	0.16	EEETK1V681AM	(9)	125
	1000	18.0	16.5	K16	1300	0.075	1.10	0.16	EEETK1V102AM	(9)	125
50	220	12.5	13.5	H13	600	0.23	3.40	0.14	EEETK1H221AQ	(10)	200
	330	12.5	13.5	H13	600	0.23	3.40	0.14	EEETK1H331AQ	(10)	200
	470	16.0	16.5	J16	900	0.15	2.20	0.14	EEETK1H471AM	(10)	125
				(J16)	900	0.15	2.20	0.14	EEETKH681UAM	(10)	125
	680	18.0	16.5	K16	950	0.14	2.10	0.14	EEETK1H681AM	(10)	125
				(K16)	950	0.14	2.10	0.14	EEETK1H102AM	(10)	125
1000	18.0	16.5	K16	950	0.14	2.10	0.14	EEETK1H102AM	(10)	125	
63	100	12.5	13.5	H13	350	0.26	5.20	0.12	EEETK1J101AQ	(11)	200
	220	12.5	13.5	H13	350	0.26	5.20	0.12	EEETK1J221AQ	(11)	200
	330	16.0	16.5	J16	500	0.18	3.60	0.12	EEETK1J331AM	(11)	125
				(J16)	500	0.18	3.60	0.12	EEETK1J471AM	(11)	125
470	16.0	16.5	J16	500	0.18	3.60	0.12	EEETK1J471AM	(11)	125	
80	47	12.5	13.5	H13	250	0.42	8.40	0.12	EEETK1K470AQ	(11)	200
	100	12.5	13.5	(H13)	250	0.42	8.40	0.12	EEETKK101UAQ	(11)	200
				J16	350	0.30	6.00	0.12	EEETK1K101AM	(11)	125
	220	16.0	16.5	(J16)	350	0.30	6.00	0.12	EEETKK221UAM	(11)	125
				K16	400	0.28	5.60	0.12	EEETK1K221AM	(11)	125
	330	18.0	16.5	(J16)	350	0.30	6.00	0.12	EEETKK331UAM	(11)	125
				K16	400	0.28	5.60	0.12	EEETK1K331AM	(11)	125
	470	18.0	16.5	K16	400	0.28	5.60	0.12	EEETK1K471AM	(11)	125
100	47	12.5	13.5	H13	250	0.42	8.40	0.10	EEETK2A470AQ	(11)	200
	100	16.0	16.5	J16	350	0.30	6.00	0.10	EEETK2A101AM	(11)	125
	220	18.0	16.5	K16	400	0.28	5.60	0.10	EEETK2A221AM	(11)	125
				(K16)	400	0.28	5.60	0.10	EEETK2A331AM	(11)	125
330	18.0	16.5	K16	400	0.28	5.60	0.10	EEETK2A331AM	(11)	125	

*1: Size code (): Miniaturization product *2: Ripple current (100 kHz / +125 °C) *3: tan δ (120 Hz / +20 °C)
 • Please refer to the page of "Reflow Profile" and "The Taping Dimensions".
 • When requesting vibration-proof product, please put the last "V" instead to "Q" or "M"

Surface Mount Type

TK series V type



Features

- Endurance : 125 °C 3000 h
- Low ESR at -40 °C (50 % lower than TG series)
- Added ESR specification after the endurance test
- Vibration-proof product (30G guaranteed) is available upon request
- AEC-Q200 compliant
- RoHS compliant

Specifications

Category temp. range	-40 °C to +125 °C				
Rated voltage range	10 V to 35 V				
Capacitance range	47 µF to 470 µF				
Capacitance tolerance	±20 % (120 Hz / +20 °C)				
Leakage current	I ≤ 0.01 CV (µA) After 2 minutes				
Dissipation factor (tan δ)	Please see the attached characteristics list				
Characteristics at low temperature	Rated voltage (V)	10	16	25	35
	Z (-25 °C) / Z (+20 °C)	3	2	2	2
	Z (-40 °C) / Z (+20 °C)	4	3	3	3
Endurance	After the life test with DC rated working voltage at +125 °C ± 2 °C for 3000 hours, the capacitors shall meet the limits specified below.				
	Capacitance change	Within ±30 % of the initial value (code U : ±35 %)			
	Dissipation factor (tan δ)	≤ 300 % of the initial limit (code U : ±350 %)			
	Leakage current	Within the initial limit			
Shelf life	After storage for 1000 hours at +125 °C ± 2 °C with no voltage applied and then being stabilized at +20 °C, capacitors shall meet the limits specified in endurance. (With voltage treatment)				
ESR after the life test	After the life test with DC rated working voltage at +125 °C ± 2 °C for 3000 hours, ESR value shall meet the specified below.				
	After 1000 hours	20 °C	≤ 150 % of the initial limit		
		-40 °C	≤ 200 % of the initial limit		
	After 2000 hours	20 °C	≤ 300 % of the initial limit		
		-40 °C	≤ 400 % of the initial limit		
	After 3000 hours	20 °C	≤ 1000 % of the initial limit		
-40 °C		≤ 1500 % of the initial limit			

Frequency correction factor for ripple current

Frequency (Hz)	120	1 k	10 k	100 k to
Correction factor	0.65	0.85	0.95	1.00

Marking

Example : 10 V 220 µF
Marking color : BLACK

Negative polarity marking (-)

Capacitance (µF)

Series identification

Mark for Lead-Free products (Black dot)

Rated voltage code

Lot number

R.voltage code	Unit : V
A 10	E 25
C 16	V 35

Dimensions

Size code	ØD	L	A, B	H	I	W	P	K
F	8.0	10.2±0.3	8.3	10.0 max.	3.4	0.90±0.2	3.1	0.70±0.2
G	10.0	10.2±0.3	10.3	12.0 max.	3.5	0.90±0.2	4.6	0.70±0.2

Unit : mm

*The dimensions of the vibration-proof products, please refer to the page of the mounting specification.

Characteristics list

Endurance : 125 °C 3000 h

Rated voltage (V)	Capacitance (±20 %) (μF)	Case size (mm)		Size code *1	Specification				Part No.	Reflow	Min. Packaging Q'ty (pcs)
		øD	L		Ripple current *2 (mA rms)	ESR (100 kHz) (Ω)		tan δ *3			Taping
						+20 °C	-40 °C				
10	220	8.0	10.2	F	197	0.3	5.0	0.30	EEETK1A221P	(8)	500
	330	8.0	10.2	(F)	197	0.3	5.0	0.30	EEETK1A331UP	(8)	500
		10.0	10.2	G	270	0.2	3.0	0.30	EEETK1A331P	(8)	500
	470	10.0	10.2	(G)	270	0.2	3.0	0.30	EEETK1A471UP	(8)	500
16	100	8.0	10.2	F	197	0.3	5.0	0.23	EEETK1C101P	(8)	500
	220	8.0	10.2	(F)	197	0.3	5.0	0.23	EEETK1C221UP	(8)	500
		10.0	10.2	G	270	0.2	3.0	0.23	EEETK1C221P	(8)	500
	330	10.0	10.2	(G)	270	0.2	3.0	0.23	EEETK1C331UP	(8)	500
25	100	8.0	10.2	F	197	0.3	5.0	0.18	EEETK1E101P	(8)	500
	220	8.0	10.2	(F)	197	0.3	5.0	0.18	EEETK1E221UP	(8)	500
		10.0	10.2	G	270	0.2	3.0	0.18	EEETK1E221P	(8)	500
	330	10.0	10.2	(G)	270	0.2	3.0	0.18	EEETK1E331UP	(8)	500
35	47	8.0	10.2	F	197	0.3	5.0	0.16	EEETK1V470P	(8)	500
	100	8.0	10.2	(F)	197	0.3	5.0	0.16	EEETK1V101UP	(8)	500
		10.0	10.2	G	270	0.2	3.0	0.16	EEETK1V101P	(8)	500
	220	10.0	10.2	(G)	270	0.2	3.0	0.16	EEETK1V221UP	(8)	500

*1: Size code(): Miniaturization product

*2: Ripple current (100 kHz / +125 °C)

*3: tan δ (120 Hz / +20 °C)

• Please refer to the page of "Reflow Profile" and "The Taping Dimensions".

• When requesting vibration-proof product, please put the last "V" instead to "P"

Surface Mount Type

TP series V type

High temperature Lead-Free reflow (suffix : A*)



Features

- Endurance : 125 °C 3000 h (D8 size : 2000 h)
- Lower ESR at Low temperature after endurance
- Automotive
- Vibration-proof product (30G guaranteed) is available upon request
- AEC-Q200 compliant
- RoHS compliant

Specifications

Category temp. range	-40 °C to +125 °C				
Rated voltage range	10 V to 35 V				
Capacitance range	47 μF to 470 μF				
Capacitance tolerance	±20 % (120 Hz / +20 °C)				
Leakage current	I ≤ 0.01 CV (μA) After 2 minutes				
Dissipation factor (tan δ)	Please see the attached characteristics list				
Endurance	After the life test with DC rated working voltage at +125 °C ± 2 °C for 3000 hours (D8 : 2000 h) the capacitors shall meet the limits specified below.				
	Capacitance change	Within ±30 % of the initial value			
	Dissipation factor (tan δ)	≤ 300 % of the initial limit			
	Leakage current	Within the initial limit			
	ESR after endurance (Ω/100 kHz)	Size code	D8	F	G
	Initial (20 °C)	0.45	0.20	0.15	
	After 2000 h (-40 °C)	40	4.5	3.5	
Shelf life	After storage for 1000 hours at +125 °C ± 2 °C with no voltage applied and then being stabilized at +20 °C, capacitors shall meet the limits specified in endurance. (With voltage treatment)				
Resistance to soldering heat	After reflow soldering and then being stabilized at +20 °C, capacitors shall meet the following limits.				
	Capacitance change	Within ±10 % of the initial value			
	Dissipation factor (tan δ)	Within the initial limit			
	Leakage current	Within the initial limit			

Frequency correction factor for ripple current

Frequency (Hz)	120	1 k	10 k	100 k to
Correction factor	0.65	0.85	0.95	1.00

Marking

Example : 10 V 220 μF
Marking color : BLACK

Negative polarity marking (-)

Capacitance (μF)
Series identification
Mark for Lead-Free products (Black dot)
Rated voltage code
Lot number

R.voltage code		Unit : V	
A	10	E	25
C	16	V	35

Dimensions

0.3 max.
øD±0.5
L
A±0.2
H
I
W
P
K
T
() Reference size

Pressure Relief (ø10 and larger)

Unit : mm

Size code	øD	L	A, B	H	I	W	P	K
D8	6.3	7.7±0.3	6.6	7.8 max.	2.6	0.65±0.1	1.8	0.35 ^{+0.15} _{-0.20}
F	8.0	10.2±0.3	8.3	10.0 max.	3.4	0.90±0.2	3.1	0.70±0.2
G	10.0	10.2±0.3	10.3	12.0 max.	3.5	0.90±0.2	4.6	0.70±0.2

*The dimensions of the vibration-proof products, please refer to the page of the mounting specification.

Characteristics list

Endurance : 125 °C 3000 h (ø6.3×7.7 : 2000 h)

Rated voltage (V)	Capacitance (±20 %) (μF)	Case size (mm)			Size code *1	Specification				Part No.		Reflow	Min. Packaging Qty (pcs) Taping
		øD	L			Ripple current *2 (mA rms)	ESR (100 kHz) (Ω)		tan δ *3	Standard Product	Vibration-proof product		
			Standard	Vibration-proof			+20 °C	-40 °C					
10	220	8.0	10.2	10.5	F	270	0.20	3.0	0.30	EEETP1A221AP	EEETP1A221AV	(8)	500
					(F)	270	0.20	3.0	0.30	EEETPA331UAP	EEETPA331UAV	(8)	500
	330	10.0	10.2	10.5	G	500	0.15	2.0	0.30	EEETP1A331AP	EEETP1A331AV	(8)	500
					G	500	0.15	2.0	0.30	EEETP1A471AP	EEETP1A471AV	(8)	500
16	100	6.3	7.7	8.0	D8	197	0.45	5.0	0.23	EEETPC101XAP	EEETPC101XAV	(8)	900
					F	270	0.20	3.0	0.23	EEETP1C101AP	EEETP1C101AV	(8)	500
	220	8.0	10.2	10.5	F	270	0.20	3.0	0.23	EEETP1C221AP	EEETP1C221AV	(8)	500
					G	500	0.15	2.0	0.23	EEETP1C331AP	EEETP1C331AV	(8)	500
					G	500	0.15	2.0	0.23	EEETP1C471AP	EEETP1C471AV	(8)	500
25	100	8.0	10.2	10.5	F	270	0.20	3.0	0.18	EEETP1E101AP	EEETP1E101AV	(8)	500
					G	500	0.15	2.0	0.18	EEETP1E221AP	EEETP1E221AV	(8)	500
					G	500	0.15	2.0	0.18	EEETP1E331AP	EEETP1E331AV	(8)	500
35	47	6.3	7.7	8.0	D8	197	0.45	5.0	0.16	EEETPV470XAP	EEETPV470XAV	(8)	900
					F	270	0.20	3.0	0.16	EEETP1V470AP	EEETP1V470AV	(8)	500
	100	8.0	10.2	10.5	F	270	0.20	3.0	0.16	EEETP1V101AP	EEETP1V101AV	(8)	500
					G	500	0.15	2.0	0.16	EEETP1V221AP	EEETP1V221AV	(8)	500

*1: Size code(): Miniaturization product

*2: Ripple current (100 kHz / +125 °C)

*3: tan δ (120 Hz / +20 °C)

• If Part number exceeds 12 digits, voltage code is abbreviated as follows; 0J → J, 1A → A, 1C → C, 1E → E, 1V → V

• Please refer to the page of "Reflow Profile" and "The Taping Dimensions".

Surface Mount Type

Medium-size TP series V type

High temperature Lead-Free reflow



Features

- Endurance : 125 °C 3000 to 4000 h
- High ripple current (2 to 5 times as high as TK series)
- Low ESR (40 to 70 % lower than TK series)
- Large capacitance (Up to 80 % larger than TK series)
- Vibration-proof product (30G guaranteed) is available upon request
- AEC-Q200 compliant
- RoHS compliant

Specifications

Category temp. range	-55 °C to +125 °C		
Rated voltage range	25 V to 80 V		
Capacitance range	390 µF to 3300 µF		
Capacitance tolerance	±20 % (120 Hz / +20 °C)		
Leakage current	I ≤ 0.01 CV (µA) After 2 minutes		
Dissipation factor (tan δ)	Please see the attached characteristics list		
Characteristics at low temperature	Rated voltage (V)	25	35 to 80
	Z (-25 °C) / Z (+20 °C)	2	2
	Z (-40 °C) / Z (+20 °C)	4	3
(Impedance ratio at 120 Hz)			
Endurance	After applying rated working voltage for 4000 hours at +125 °C ± 2 °C and then being stabilized at +20 °C, Capacitors shall meet the following limits. (J16, K16 size : 3000 h)		
	Capacitance change	Within ±30 % of the initial value (35 V or less : Within ±35 %)	
	Dissipation factor (tan δ)	≤ 300 % of the initial limit	
	Leakage current	Within the initial limit	
Shelf life	After storage for 1000 hours at +125 °C ± 2 °C with no voltage applied and then being stabilized at +20 °C, capacitors shall meet the limits specified in endurance. (With voltage treatment)		
	After reflow soldering and then being stabilized at +20 °C, capacitors shall meet the following limits.		
Resistance to soldering heat	Capacitance change	Within ±10 % of the initial value	
	Dissipation factor (tan δ)	Within the initial limit	
	Leakage current	Within the initial limit	

Frequency correction factor for ripple current

Frequency (Hz)	120	1 k	10 k	100 k to
Correction factor	0.75	0.90	0.95	1.00

Marking

Example : 25 V 1800 µF
Marking color : BLACK

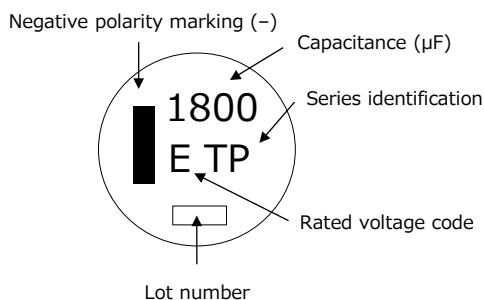

R.voltage code	Unit : V
E	25
V	35
H	50

Unit : V	Series
63	J
70	K

Dimensions

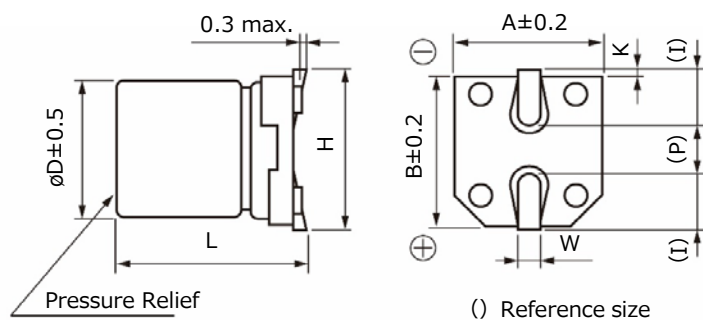

Unit : mm

Size code	øD	L	A, B	H	I	W	P	K
J16	16.0	16.5±0.5	17.0	19.0 max.	5.5	1.20±0.3	6.7	0.70±0.3
K16	18.0	16.5±0.5	19.0	21.0 max.	6.7	1.20±0.3	6.7	0.70±0.3
K21	18.0	21.5±0.5	19.0	21.0 max.	6.7	1.20±0.3	6.7	0.70±0.3

*The dimensions of the vibration-proof products, please refer to the page of the mounting specification.

Characteristics list

Endurance : 125 °C 4000 h (J16, K16 size : 3000 h)

Rated voltage (V)	Capacitance (±20 %) (µF)	Case size (mm)			Size code	Specification			Part No.		Reflow	Min. Packaging Q'ty (pcs)
		øD	L			Ripple current*1 (mA rms)	ESR*2 (Ω)	tan δ*3	Standard Product	Vibration-proof product		Taping
			Standard	Vibration-proof								
25	1800	16.0	16.5	16.8	J16	2400	0.047	0.18	EEETP1E182M	EEETP1E182V	(9)	125
	2700	18.0	16.5	16.8	K16	2600	0.045	0.20	EEETP1E272M	EEETP1E272V	(9)	125
	3300	18.0	21.5	21.8	K21	3250	0.032	0.22	EEETP1E332M	EEETP1E332V	(9)	75
35	1300	16.0	16.5	16.8	J16	2400	0.047	0.16	EEETP1V132M	EEETP1V132V	(9)	125
	1800	18.0	16.5	16.8	K16	2600	0.045	0.16	EEETP1V182M	EEETP1V182V	(9)	125
	2400	18.0	21.5	21.8	K21	3250	0.032	0.18	EEETP1V242M	EEETP1V242V	(9)	75
50	750	16.0	16.5	16.8	J16	2000	0.080	0.14	EEETP1H751M	EEETP1H751V	(10)	125
	1000	18.0	16.5	16.8	K16	2100	0.078	0.14	EEETP1H102M	EEETP1H102V	(10)	125
	1300	18.0	21.5	21.8	K21	2900	0.060	0.14	EEETP1H132M	EEETP1H132V	(10)	75
63	560	16.0	16.5	16.8	J16	1900	0.100	0.12	EEETP1J561M	EEETP1J561V	(11)	125
	750	18.0	16.5	16.8	K16	2000	0.095	0.12	EEETP1J751M	EEETP1J751V	(11)	125
	1000	18.0	21.5	21.8	K21	2600	0.068	0.12	EEETP1J102M	EEETP1J102V	(11)	75
70	470	16.0	16.5	16.8	J16	1900	0.100	0.12	EEETP70471M	EEETP70471V	(11)	125
	680	18.0	16.5	16.8	K16	2000	0.095	0.12	EEETP70681M	EEETP70681V	(11)	125
	820	18.0	21.5	21.8	K21	2600	0.068	0.12	EEETP70821M	EEETP70821V	(11)	75
80	390	16.0	16.5	16.8	J16	1900	0.100	0.12	EEETP1K391M	EEETP1K391V	(11)	125
	510	18.0	16.5	16.8	K16	2000	0.095	0.12	EEETP1K511M	EEETP1K511V	(11)	125
	680	18.0	21.5	21.8	K21	2600	0.068	0.12	EEETP1K681M	EEETP1K681V	(11)	75

*1: Ripple current (100 kHz / +125 °C)

*2: ESR (100 kHz / +20 °C)

*3: tan δ (120 Hz / +20 °C)

• Please refer to the page of "Reflow Profile" and "The Taping Dimensions".

Surface Mount Type

TC series V type

High temperature Lead-Free reflow



Features

- Endurance: 125 °C 3000 h (D8 size: 2000 h)
- High ripple current (50 % higher than TP series)
- Added ESR specification after the endurance test
- Vibration-proof product (30G guaranteed) is available upon request ($\phi 6.3 \leq$)
- AEC-Q200 compliant
- RoHS compliant

Specifications

Category temp. range	-40 °C to +125 °C				
Rated voltage range	10 V to 35 V				
Capacitance range	47 μ F to 470 μ F				
Capacitance tolerance	± 20 % (120 Hz / +20 °C)				
Leakage current	$I \leq 0.01 CV$ (μ A) After 2 minutes				
Dissipation factor (tan δ)	Please see the attached characteristics list				
Endurance	After applying rated working voltage for 3000 hours (D8 : 2000 h) at +125 °C ± 2 °C and then being stabilized at +20 °C, capacitors shall meet the following limits.				
	Capacitance change	Within ± 30 % of the initial value			
	Dissipation factor (tan δ)	≤ 300 % of the initial limit			
	Leakage current	Within the initial limit			
ESR after endurance ($\Omega/100kHz$)	Size code	D8	F	G	
	Initial (20 °C)	0.45	0.20	0.15	
	After 2000 h (-40 °C)	40	4.5	3.5	
Shelf life	After storage for 1000 hours at +125 °C ± 2 °C with no voltage applied and then being stabilized at +20 °C, capacitors shall meet the limits specified in endurance. (With voltage treatment)				
Resistance to soldering heat	After reflow soldering and then being stabilized at +20 °C, capacitors shall meet the following limits.				
	Capacitance change	Within ± 10 % of the initial value			
	Dissipation factor (tan δ)	Within the initial limit			
	Leakage current	Within the initial limit			

Frequency correction factor for ripple current

Frequency (Hz)	120	1 k	10 k	100 k to
Correction factor	0.65	0.85	0.95	1.00

Marking

Example : 10 V 220 μ F
Marking color : BLACK

Negative polarity marking (-)

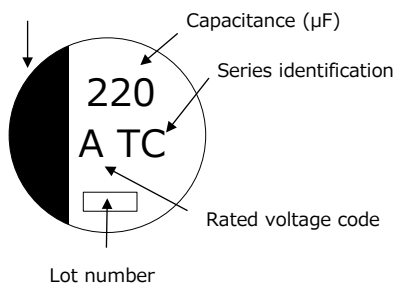

R.voltage code		Unit : V	
A	10	E	25
C	16	V	35

Dimensions

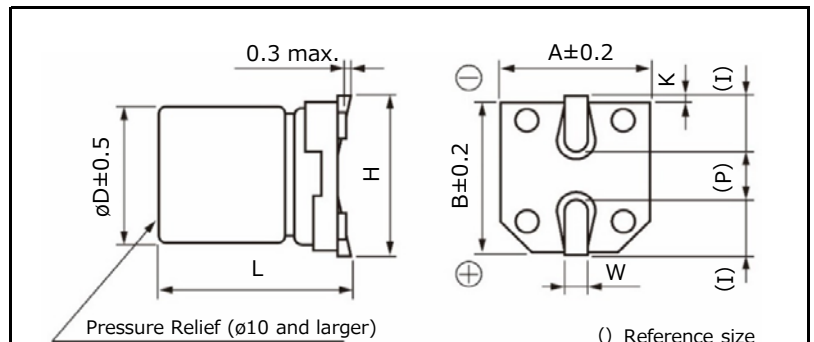

Size code	ϕD	L	A, B	H	I	W	P	K
D8	6.3	7.7 \pm 0.3	6.6	7.8 max.	2.6	0.65 \pm 0.1	1.8	0.35 ^{+0.15} _{-0.20}
F	8.0	10.2 \pm 0.3	8.3	10.0 max.	3.4	0.90 \pm 0.2	3.1	0.70 \pm 0.2
G	10.0	10.2 \pm 0.3	10.3	12.0 max.	3.5	0.90 \pm 0.2	4.6	0.70 \pm 0.2

*The dimensions of the vibration-proof products, please refer to the page of the mounting specification.

Characteristics list

Endurance : 125 °C 3000 h (D8 size : 2000 h)

Rated voltage (V)	Capacitance (±20 %) (µF)	Case size (mm)			Size code	Specification				Part No.		Reflow	Min. Packaging Qty (pcs)
		øD	L			Ripple current*1 (mA rms)	ESR (100 kHz) (Ω)		tan δ*2	Standard Product	Vibration-proof product		
			Standard	Vibration-proof			+20 °C	-40 °C					
10	220	8.0	10.2	10.5	F	410	0.20	3.0	0.30	EEETC1A221P	EEETC1A221V	(8)	500
	330	10.0	10.2	10.5	G	750	0.15	2.0	0.30	EEETC1A331P	EEETC1A331V	(8)	500
	470	10.0	10.2	10.5	G	750	0.15	2.0	0.30	EEETC1A471P	EEETC1A471V	(8)	500
16	100	6.3	7.7	8.0	D8	300	0.45	5.0	0.23	EEETC1C101XP	EEETC1C101XV	(8)	900
		8.0	10.2	10.5	F	410	0.20	3.0	0.23	EEETC1C101P	EEETC1C101V	(8)	500
	220	8.0	10.2	10.5	F	410	0.20	3.0	0.23	EEETC1C221P	EEETC1C221V	(8)	500
	330	10.0	10.2	10.5	G	750	0.15	2.0	0.23	EEETC1C331P	EEETC1C331V	(8)	500
	470	10.0	10.2	10.5	G	750	0.15	2.0	0.23	EEETC1C471P	EEETC1C471V	(8)	500
25	100	8.0	10.2	10.5	F	410	0.20	3.0	0.18	EEETC1E101P	EEETC1E101V	(8)	500
	220	10.0	10.2	10.5	G	750	0.15	2.0	0.18	EEETC1E221P	EEETC1E221V	(8)	500
	330	10.0	10.2	10.5	G	750	0.15	2.0	0.18	EEETC1E331P	EEETC1E331V	(8)	500
35	47	6.3	7.7	8.0	D8	300	0.45	5.0	0.16	EEETC1V470XP	EEETC1V470XV	(8)	900
		8.0	10.2	10.5	F	410	0.20	3.0	0.16	EEETC1V470P	EEETC1V470V	(8)	500
	100	8.0	10.2	10.5	F	410	0.20	3.0	0.16	EEETC1V101P	EEETC1V101V	(8)	500
	220	10.0	10.2	10.5	G	750	0.15	2.0	0.16	EEETC1V221P	EEETC1V221V	(8)	500

*1: Ripple current (100 kHz / +125 °C)

*2: tan δ (120 Hz / +20 °C)

• Please refer to the page of "Reflow Profile" and "The Taping Dimensions".

Surface Mount Type

TCU series V type

High temperature Lead-Free reflow



Features

- Endurance : 125 °C 3000 h
- Miniaturization (20 % to 40 % less than TP series)
- Added ESR specification after the endurance test
- Vibration-proof product (30G guaranteed) is available upon request
- AEC-Q200 compliant
- RoHS compliant

Specifications

Category temp. range	-40 °C to +125 °C			
Rated voltage range	10 V to 35 V			
Capacitance range	220 µF to 680 µF			
Capacitance tolerance	±20 % (120 Hz / +20 °C)			
Leakage current	I ≤ 0.01 CV (µA) After 2 minutes			
Dissipation factor (tan δ)	Please see the attached characteristics list			
Endurance	After applying rated working voltage for 3000 hours at +125 °C ± 2 °C and then being stabilized at +20 °C, capacitors shall meet the following limits.			
	Capacitance change	Within ±30 % of the initial value		
	Dissipation factor (tan δ)	≤ 300 % of the initial limit		
	Leakage current	Within the initial limit		
ESR after endurance (Ω/100kHz)	Size code	F	G	
	Initial (20 °C)	0.20	0.15	
	After 2000 h (-40 °C)	9	7	
Shelf life	After storage for 1000 hours at +125 °C ± 2 °C with no voltage applied and then being stabilized at +20 °C, capacitors shall meet the limits specified in endurance. (With voltage treatment)			
Resistance to soldering heat	After reflow soldering and then being stabilized at +20 °C, capacitors shall meet the following limits.			
	Capacitance change	Within ±10 % of the initial value		
	Dissipation factor (tan δ)	Within the initial limit		
	Leakage current	Within the initial limit		

Frequency correction factor for ripple current

Frequency (Hz)	120	1 k	10 k	100 k to
Correction factor	0.65	0.85	0.95	1.00

Marking

Example : 10 V 330 µF
Marking color : BLACK

Negative polarity marking (-)

Capacitance (µF)
Series identification
Rated voltage code
Lot number

R.voltage code	Unit : V
A	10
C	16
E	25
V	35

Dimensions

Pressure Relief (ø10 and larger)

() Reference size

Size code	øD	L	A, B	H	I	W	P	K
F	8.0	10.2±0.3	8.3	10.0 max.	3.4	0.90±0.2	3.1	0.70±0.2
G	10.0	10.2±0.3	10.3	12.0 max.	3.5	0.90±0.2	4.6	0.70±0.2

Unit : mm

*The dimensions of the vibration-proof products, please refer to the page of the mounting specification.

Characteristics list

Endurance : 125 °C 3000 h

Rated voltage (V)	Capacitance (±20 %) (µF)	Case size (mm)			Size code	Specification				Part No.		Reflow	Min. Packaging Qty (pcs)
		øD	L			Ripple current*1 (mA rms)	ESR (100 kHz) (Ω)		tan δ*2	Standard Product	Vibration-proof product		
			Standard	Vibration-proof			+20 °C	-40 °C					
10	330	8.0	10.2	10.5	F	410	0.20	3.0	0.30	EEETC1A331UP	EEETC1A331UV	(8)	500
	470	8.0	10.2	10.5	F	410	0.20	3.0	0.30	EEETC1A471UP	EEETC1A471UV	(8)	500
	560	8.0	10.2	10.5	F	410	0.20	3.0	0.30	EEETC1A561UP	EEETC1A561UV	(8)	500
	680	10.0	10.2	10.5	G	750	0.15	2.0	0.30	EEETC1A681UP	EEETC1A681UV	(8)	500
16	330	8.0	10.2	10.5	F	410	0.20	3.0	0.23	EEETC1C331UP	EEETC1C331UV	(8)	500
	390	8.0	10.2	10.5	F	410	0.20	3.0	0.23	EEETC1C391UP	EEETC1C391UV	(8)	500
	680	10.0	10.2	10.5	G	750	0.15	2.0	0.23	EEETC1C681UP	EEETC1C681UV	(8)	500
25	220	8.0	10.2	10.5	F	410	0.20	3.0	0.18	EEETC1E221UP	EEETC1E221UV	(8)	500
	330	8.0	10.2	10.5	F	410	0.20	3.0	0.18	EEETC1E331UP	EEETC1E331UV	(8)	500
	470	10.0	10.2	10.5	G	750	0.15	2.0	0.18	EEETC1E471UP	EEETC1E471UV	(8)	500
35	220	8.0	10.2	10.5	F	410	0.20	3.0	0.16	EEETC1V221UP	EEETC1V221UV	(8)	500
	330	10.0	10.2	10.5	G	750	0.15	2.0	0.16	EEETC1V331UP	EEETC1V331UV	(8)	500
	390	10.0	10.2	10.5	G	750	0.15	2.0	0.16	EEETC1V391UP	EEETC1V391UV	(8)	500

*1: Ripple current (100 kHz / +125 °C)

*2: tan δ (120 Hz / +20 °C)

• Please refer to the page of "Reflow Profile" and "The Taping Dimensions".

Surface Mount Type

TQ series **V** type

High temperature Lead-Free reflow (suffix : A*)



Features

- Endurance : 125 °C 2000 h
- 1 size smaller and same performance compare with V-TK series
- Low ESR (85 % low ESR in low temperature after endurance compare with V-TP series)
- Vibration-proof product (30G guaranteed) is available upon request
- AEC-Q200 compliant
- RoHS compliant

Specifications

Category temp. range	-40 °C to +125 °C		
Rated voltage range	35 V		
Capacitance range	47 µF to 100 µF		
Capacitance tolerance	±20 % (120 Hz / +20°C)		
Leakage current	I ≤ 0.01 CV (µA) After 2 minutes		
Dissipation factor (tan δ)	Please see the attached characteristics list		
Endurance	After the life test with DC rated working voltage at +125 °C ± 2 °C for 2000 hours, the capacitors shall meet the limits specified below.		
	Capacitance change	Within ±30 % of the initial value	
	Dissipation factor (tan δ)	≤ 300 % of the initial limit	
	Leakage current	Within the initial limit	
	ESR after endurance (Ω/100 kHz)	Size code	D8
	Initial (20 °C)	0.30	
	After 2000 h (-40 °C)	6	
Shelf life	After storage for 1000 hours at +125 °C ± 2 °C with no voltage applied and then being stabilized at +20 °C, capacitors shall meet the limits specified in endurance. (With voltage treatment)		
Resistance to soldering heat	After reflow soldering and then being stabilized at +20 °C, capacitors shall meet the following limits.		
	Capacitance change	Within ±10 % of the initial value	
	Dissipation factor (tan δ)	Within the initial limit	
	Leakage current	Within the initial limit	

Frequency correction factor for ripple current

Frequency (Hz)	120	1 k	10 k	100 k to
Correction factor	0.65	0.85	0.95	1.00

Marking

Example : 35 V 47 µF
Marking color : BLACK

Negative polarity marking (-)

Capacitance (µF)

Series identification

Rated voltage code

Lot number

R.voltage code	Unit : V
V	35

Dimensions

() Reference size

Unit : mm

Size code	øD	L	A, B	H	I	W	P	K
D8	6.3	7.7±0.3	6.6	7.8 max.	2.6	0.65±0.1	1.8	0.35 ^{+0.15} _{-0.20}

*The dimensions of the vibration-proof products, please refer to the page of the mounting specification.

Characteristics list

Endurance : 125 °C 2000 h

Rated voltage (V)	Capacitance (±20 %) (μF)	Case size (mm)			Size code	Specification			Part No.		Reflow	Min. Packaging Q'ty(pcs)
		øD	L			Ripple current*1 (mA rms)	ESR*2 (Ω)	tan δ*3	Standard Product	Vibration-proof product		Taping
			Standard	Vibration-proof								
35	47	6.3	7.7	8.0	D8	197	0.30	0.16	EEETQV470XAP	EEETQV470XAV	(5)	900
	100	6.3	7.7	8.0	D8	197	0.30	0.16	EEETQV101XAP	EEETQV101XAV	(5)	900

*1: Ripple current (100 kHz / +125 °C)

*2: ESR (100 kHz / +20 °C)

*3: tan δ (120 Hz / +20 °C)

• If Part number exceeds 12 digits, voltage code is abbreviated as follows; 1V → V

• Please refer to the page of "Reflow Profile" and "The Taping Dimensions".

Surface Mount Type Large can-size EB series V type



Features

- Endurance : 105 °C 3000 to 5000 h
- RoHS compliant

Specifications

Category temp. range	-25 °C to +105 °C							
Rated voltage range	160 V to 450 V							
Capacitance range	2.2 μF to 100 μF							
Capacitance tolerance	±20 % (120 Hz / +20 °C)							
Leakage current	I ≤ 0.06 CV+10 (μA) After 2 minutes							
Dissipation factor (tan δ)	Please see the attached characteristics list							
Characteristics at low temperature	Rated voltage (V)	160	200	250	350	400	450	(Impedance ratio at 120 Hz)
	Z (-25 °C) / Z (+20 °C)	2	2	3	5	6	6	
Endurance	After the life test with DC rated working voltage at +105 °C ± 2 °C for 5000 hours, the capacitors shall meet the limits specified below. (Size code G13 : 3000 hours, G17 : 4000 hours)							
	Capacitance change	Within ±20 % of the initial value						
	Dissipation factor (tan δ)	≤ 200 % of the initial limit						
	Leakage current	Within the initial limit						
Shelf life	After storage for 1000 hours at +105 °C ± 2 °C with no voltage applied and then being stabilized at +20 °C, capacitors shall meet the limits specified in endurance. (With voltage treatment)							
Resistance to soldering heat	After reflow soldering and then being stabilized at +20 °C, capacitors shall meet the following limits.							
	Capacitance change	Within ±10 % of the initial value						
	Dissipation factor (tan δ)	Within the initial limit						
	Leakage current	Within the initial limit						

Frequency correction factor for ripple current

Cap. (μF) \ Freq. (Hz)	120	1 k	10 k ≤ f < 30 k	30 k ≤ f ≤ 100 k
160 ~ 250	0.55	0.85	0.90	1.00
350 ~ 450	0.50	0.80	0.90	1.00

Marking

Example : 160 V 10 μF
Marking color : BLACK

Negative polarity marking (-)

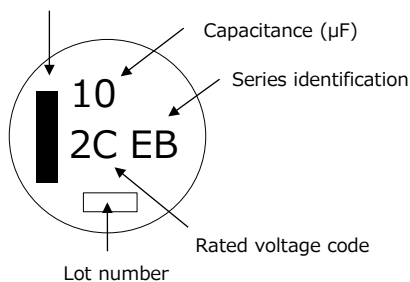

R.voltage code

Unit : V

2C	160	2V	350
2D	200	2G	400
2E	250	2W	450

Dimensions

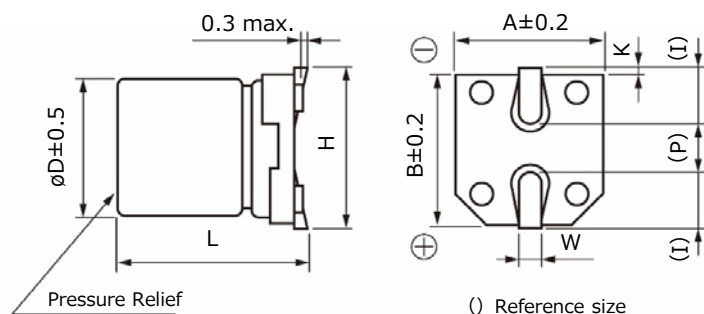

Unit : mm

Size code	øD	L	A, B	H	I	W	P	K
G13	10.0	13.5 ^{+0.5} _{-1.0}	10.3	12.0 max.	3.5	0.9±0.2	4.6	0.70±0.20
G17	10.0	16.5 ^{+0.5} _{-1.0}	10.3	12.0 max.	3.5	0.9±0.2	4.6	0.70±0.20
H16	12.5	16.5 ^{+0.5} _{-1.0}	13.5	15.0 max.	4.7	0.9±0.3	4.4	0.70±0.30
J16	16.0	16.5±0.5	17.0	19.0 max.	5.5	1.2±0.3	6.7	0.70±0.30
J21	16.0	21.5±0.5	17.0	19.0 max.	5.5	1.2±0.3	6.7	0.70±0.30
K16	18.0	16.5±0.5	19.0	21.0 max.	6.7	1.2±0.3	6.7	0.70±0.30
K21	18.0	21.5±0.5	19.0	21.0 max.	6.7	1.2±0.3	6.7	0.70±0.30

*The dimensions of the vibration-proof products, please refer to the page of the mounting specification.

Characteristics list

Endurance : 105 °C 5000 h (G13 : 3000 h, G17 : 4000 h)

Rated voltage (V)	Capacitance (±20 %) (µF)	Case size (mm)		Size code	Specification			Part No.	Reflow	Min. Packaging Q'ty (pcs)
		øD	L		Ripple current *1 (mA rms)	tanδ*2	Endurance (hours)			Taping
160	10	10.0	13.5	G13	70	0.15	3000	EEVEB2C100Q	(4)	250
	33	12.5	16.5	H16	470	0.15	5000	EEVEB2C330SQ	(4)	150
	47	16.0	16.5	J16	600	0.15	5000	EEVEB2C470SM	(4)	125
	68	16.0	21.5	J21	750	0.15	5000	EEVEB2C680M	(4)	75
		18.0	16.5	K16	750	0.15	5000	EEVEB2C680SM	(4)	125
100	18.0	21.5	K21	1060	0.15	5000	EEVEB2C101M	(4)	75	
200	10	10.0	16.5	G17	80	0.15	4000	EEVEB2D100Q	(4)	200
	22	12.5	16.5	H16	470	0.15	5000	EEVEB2D220SQ	(4)	150
	33	16.0	16.5	J16	600	0.15	5000	EEVEB2D330SM	(4)	125
	47	18.0	16.5	K16	600	0.15	5000	EEVEB2D470SM	(4)	125
	68	16.0	21.5	J21	750	0.15	5000	EEVEB2D680M	(4)	75
100	18.0	21.5	K21	1060	0.15	5000	EEVEB2D101M	(4)	75	
250	10	10.0	16.5	G17	88	0.15	4000	EEVEB2E100Q	(4)	200
	22	16.0	16.5	J16	560	0.15	5000	EEVEB2E220SM	(4)	125
	33	18.0	16.5	K16	560	0.15	5000	EEVEB2E330SM	(4)	125
	47	16.0	21.5	J21	710	0.15	5000	EEVEB2E470M	(4)	75
	68	18.0	21.5	K21	990	0.15	5000	EEVEB2E680M	(4)	75
350	3.3	10.0	13.5	G13	38	0.20	3000	EEVEB2V3R3Q	(4)	250
	4.7	10.0	16.5	G17	50	0.20	4000	EEVEB2V4R7Q	(4)	200
	10	16.0	16.5	J16	270	0.20	5000	EEVEB2V100SM	(4)	125
	22	18.0	16.5	K16	350	0.20	5000	EEVEB2V220SM	(4)	125
	33	16.0	21.5	J21	480	0.20	5000	EEVEB2V330M	(4)	75
	47	18.0	21.5	K21	670	0.20	5000	EEVEB2V470M	(4)	75
400	3.3	10.0	13.5	G13	40	0.24	3000	EEVEB2G3R3Q	(4)	250
	4.7	10.0	16.5	G17	50	0.24	4000	EEVEB2G4R7Q	(4)	200
	10	16.0	16.5	J16	250	0.24	5000	EEVEB2G100SM	(4)	125
	22	16.0	21.5	J21	410	0.24	5000	EEVEB2G220M	(4)	75
	33	18.0	21.5	K21	600	0.24	5000	EEVEB2G330M	(4)	75
450	2.2	10.0	13.5	G13	29	0.24	3000	EEVEB2W2R2Q	(4)	250
	3.3	10.0	16.5	G17	41	0.24	4000	EEVEB2W3R3Q	(4)	200
	4.7	12.5	16.5	H16	49	0.24	5000	EEVEB2W4R7SQ	(4)	150
	10	18.0	16.5	K16	310	0.24	5000	EEVEB2W100SM	(4)	125
	22	18.0	21.5	K21	560	0.24	5000	EEVEB2W220M	(4)	75

*1: Ripple current (100 kHz / +125 °C)

*2: tan δ (120 Hz / +20 °C)

- Please refer to the page of "Reflow Profile" and "The Taping Dimensions".
- When requesting vibration-proof product, please put the last "V" instead to "Q or M"

CAUTION AND WARNING

1. The electronic components contained in this catalog are designed and produced for use in home electric appliances, office equipment, information equipment, communications equipment, and other general purpose electronic devices.
Before use of any of these components for equipment that requires a high degree of safety, such as medical instruments, aerospace equipment, disaster-prevention equipment, security equipment, vehicles (automobile, train, vessel), please be sure to contact our sales representative corporation.
2. When applying one of these components for equipment requiring a high degree of safety, no matter what sort of application it might be, be sure to install a protective circuit or redundancy arrangement to enhance the safety of your equipment. In addition, please carry out the safety test on your own responsibility.
3. When using our products, no matter what sort of equipment they might be used for, be sure to make a written agreement on the specifications with us in advance.
4. Technical information contained in this catalog is intended to convey examples of typical performances and or applications and is not intended to make any warranty with respect to the intellectual property rights or any other related rights of our company or any third parties nor grant any license under such rights.
5. In order to export products in this catalog, the exporter may be subject to the export license requirement under the Foreign Exchange and Foreign Trade Law of Japan.
6. No ozone-depleting substances (ODSs) under the Montreal Protocol are used in the manufacturing processes of Automotive & Industrial Systems Company, Panasonic Corporation.

● Please contact

● Factory

Device Solutions Business Division
Industrial Solutions Company

Panasonic[®]

1006 Kadoma, Kadoma City, Osaka 571-8506,
JAPAN

The information in this catalog is valid as of February 2020.