

SPECIFICATION
MODEL : SPHWHTL3D303E6R0K3

[Approved Rank : $V_F(E6)$, $CCT(R0)$, $Im_v(K3)$]

3535 Ceramic PKG



CUSTOMER :		
DRAWN	CHECKED	APPROVED

SAMSUNG LED		
DRAWN	CHECKED	APPROVED

SAMSUNG LED CO.,LTD.
314, MAETAN3-DONG, YEONGTONG-GU,
SUWON-City, GYEONGGI-DO, KOREA,443-743

Contents

1.	Product Outline	-----	3
2.	Absolute Maximum Rating	-----	3
3.	Characteristics	-----	3
4.	Typical Characteristics Graph	-----	6
5.	Outline Drawing & Dimension	-----	7
6.	Reliability Test Items & Conditions	-----	8
7.	Solder Conditions	-----	9
8.	Taping Dimension	-----	10
9.	Label Structure	-----	11
10.	Lot Number	-----	11
11.	Reel Packing Structure	-----	12
12.	Aluminium Packing Bag	-----	13
13.	Precaution For Use	-----	14
14.	Hazard Substance Analysis	-----	15
15.	Revision History	-----	18

1. Product Outline

- . Ceramic Package (3.5 x 3.5 x 1.89t mm)
- . Wide Viewing Angle ($\Delta\theta$: 125° x 125°) for uniform illuminance
- . InGaN/GaN MQW LED with Long-time Reliability
- . Lead (Pb) free product – RoHS compliant

2. Absolute Maximum Rating

- 1) Operation Forward Current ($T_a = 25^\circ\text{C}$) 1500 mA
- 2) Thermal Resistance ($R_{th,j-c}$) 6.1 $^\circ\text{C}/\text{W}$
- 3) LED Junction Temperature (T_J) 150 $^\circ\text{C}$
- 4) Operating Temperature Range (T_{opr}) -40 $^\circ\text{C}$ ~ 85 $^\circ\text{C}$
- 5) Storage Temperature Range (T_{stg}) -40 $^\circ\text{C}$ ~ 100 $^\circ\text{C}$

3. Characteristics

- 1) Electro-Optical characteristics

($T_a : 25^\circ\text{C}$)

CCT(K)	Item	Unit	Condition	Rank	Min	Typ	Max
5000K	Luminous Flux	lm	$I_F = 350\text{ mA}$	K3	130	-	160
	Forward Voltage (V_F)	V		E6	2.7	-	3.3
	CRI			-	70	-	-
	Viewing Angle	$^\circ$		-	-	125 $^\circ$	-
	Size	mm		3.5 x 3.5 x 1.89			

2) Chromaticity Diagram

 ($T_a : 25^{\circ}\text{C}$)

3) Chromaticity Coordinates

TABLE	Rank	CIE X	CIE Y	Rank	CIE X	CIE Y
5000K (R0)	R1	0.3371	0.3490	R5	0.3366	0.3369
		0.3451	0.3554		0.3440	0.3428
		0.3440	0.3427		0.3429	0.3307
		0.3366	0.3369		0.3361	0.3245
	R2	0.3451	0.3554	R6	0.3440	0.3428
		0.3533	0.3620		0.3515	0.3487
		0.3515	0.3487		0.3495	0.3339
		0.3440	0.3427		0.3429	0.3307
	R3	0.3376	0.3616	R7	0.3381	0.3762
		0.3463	0.3687		0.3480	0.3840
		0.3451	0.3554		0.3463	0.3687
		0.3371	0.3490		0.3376	0.3616
	R4	0.3463	0.3687	R8	0.3480	0.3840
		0.3551	0.3760		0.3571	0.3907
		0.3533	0.3620		0.3551	0.3760
		0.3451	0.3554		0.3463	0.3687

4) VF Rank

Parameter	Symbol	Condition	Rank	Rank	Min.	Typ.	Max.
Forward Voltage	V_F	$I_F = 350\text{mA}$	E6	E3	2.7	-	3.0
				H3	3.0	-	3.3

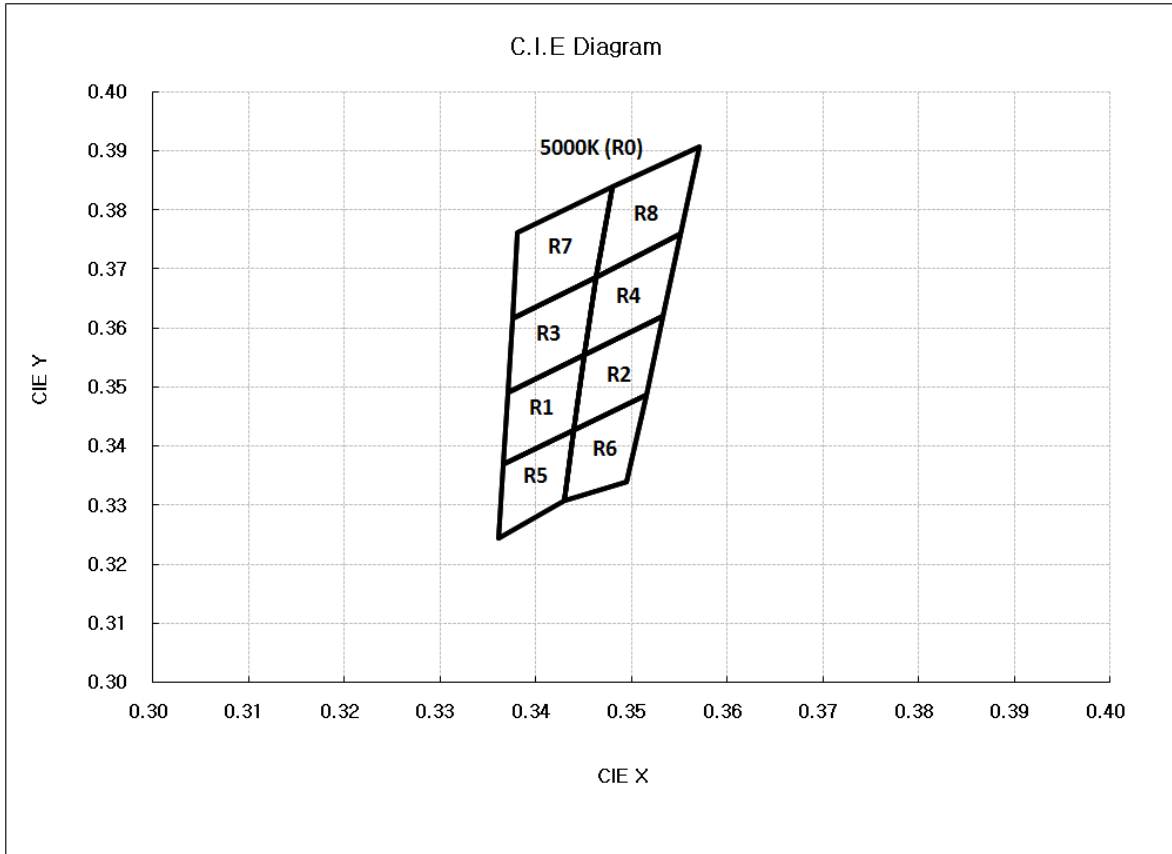
5) Luminous flux Rank

Parameter	Symbol	Condition	Rank	Rank	Min.	Typ.	Max.
Luminous Flux	Φ_V	$I_F = 350\text{mA}$	K3	K1	130	-	140
				M1	140	-	150
				N1	150	-	160

Notes:

- 1) Samsung LED has $\pm 7\%$ tolerance of flux measurements
- 2) Samsung LED has $\pm 0.1\text{V}$ tolerance of forward voltage measurements
- 3) Samsung LED has ± 3.0 tolerance of CRI measurements
- 4) Samsung LED has ± 0.01 tolerance of CCx, CCy
- 5) Samsung LED has $\pm 0.13\text{mm}$ tolerance on device dimensions.

4. Typical Characteristics Graph

($T_a = 25^\circ\text{C}$)

Normalized Flux vs. Forward Current

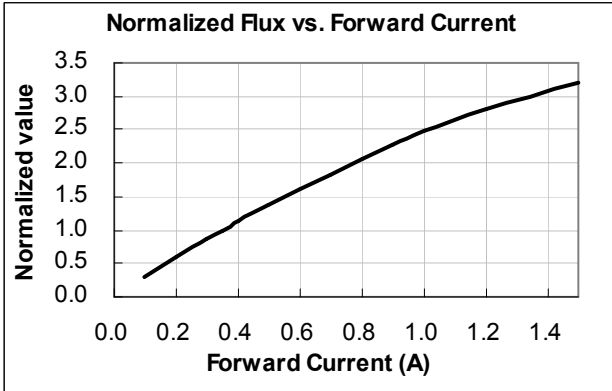

Forward Current vs. Forward Voltage

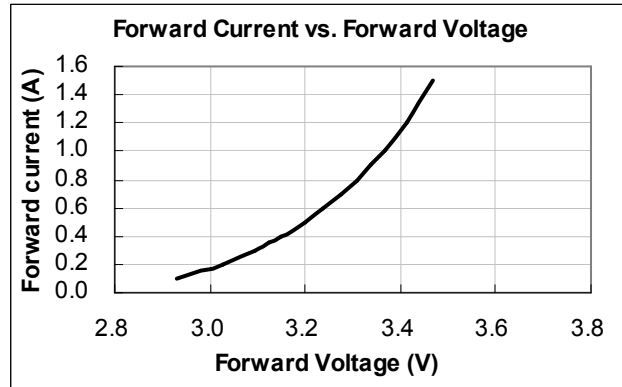

Normalized Flux vs. Junction Temp.

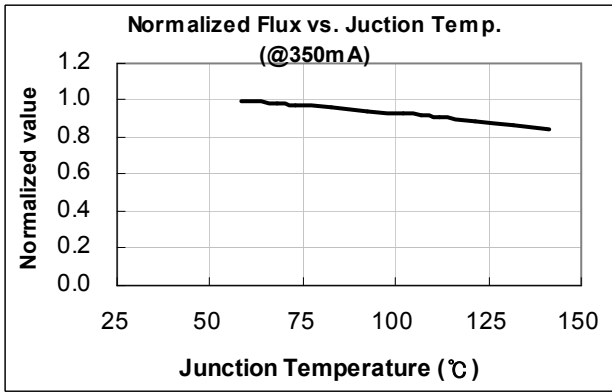

Substrate Temp. vs. Forward Voltage

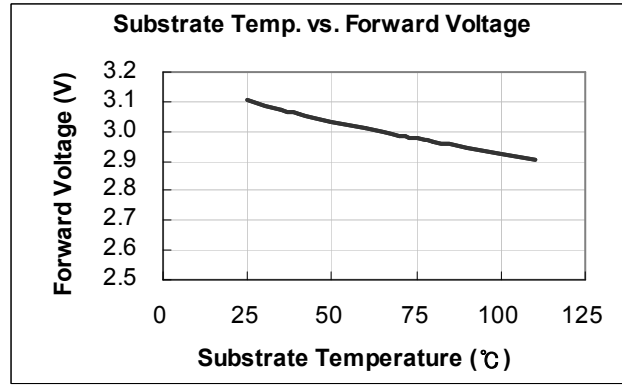

Spectrum Distribution

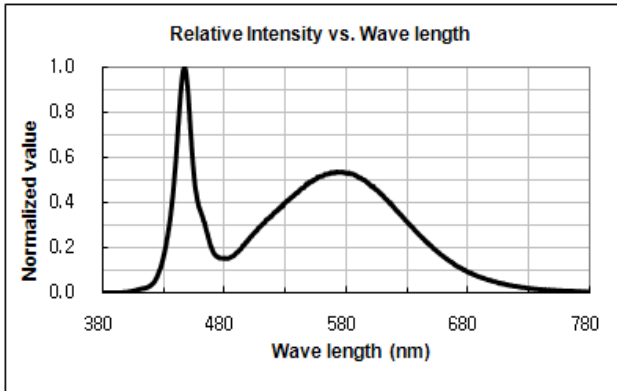

Derating Curve

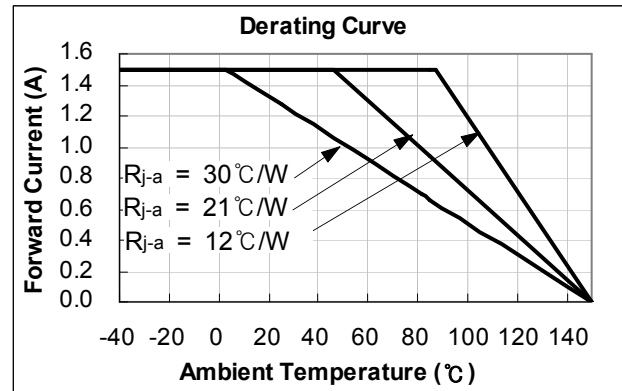

Forward Current vs. Color x,y

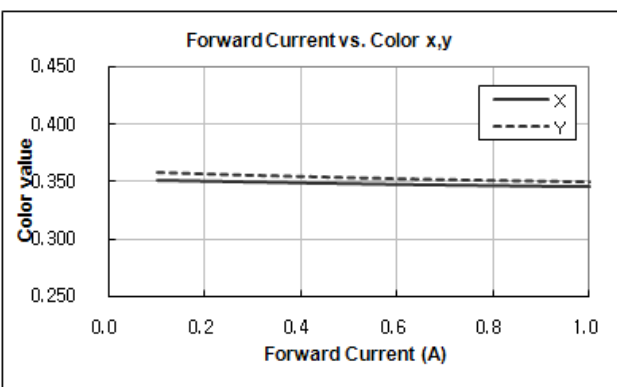

Viewing angle vs. Color Value

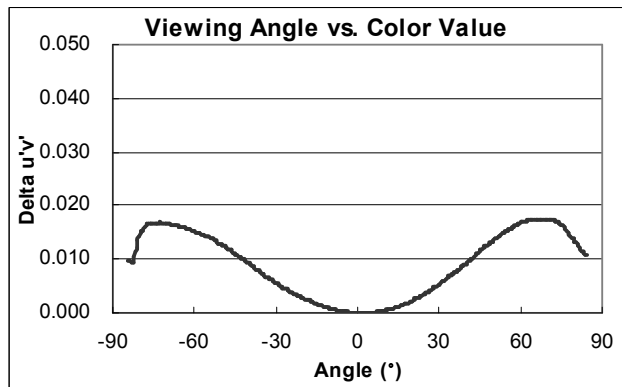

Viewing Angle

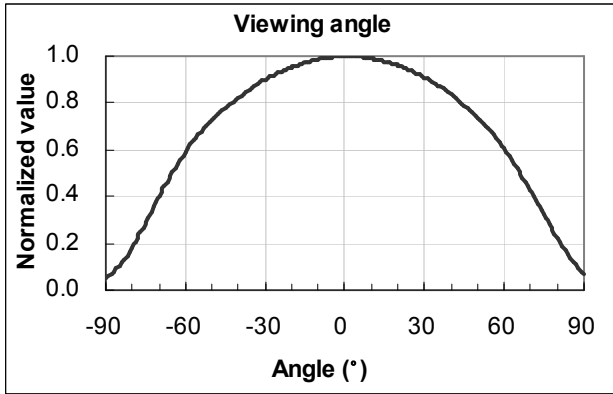

5. Outline Drawing & Dimension

unit : mm
Tolerance : ± 0.13

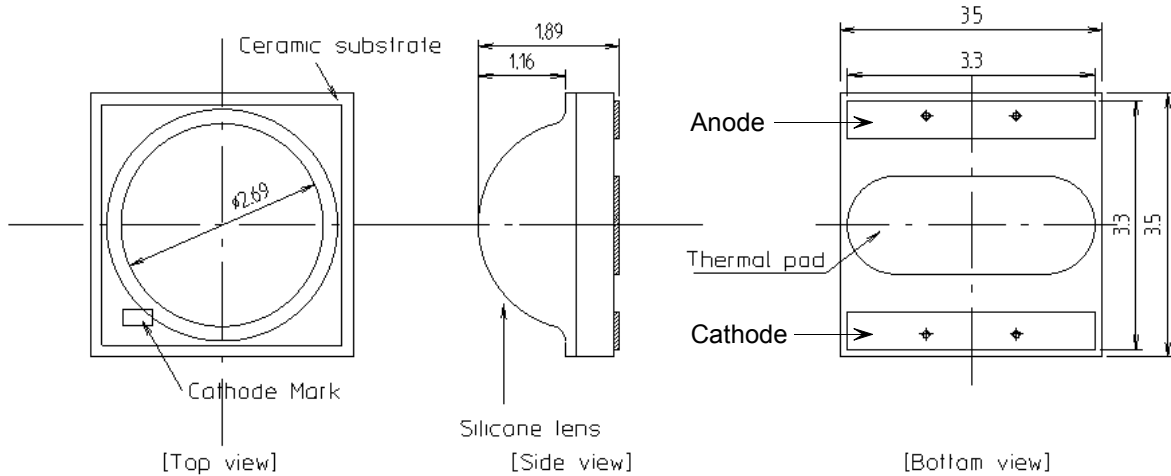

Recommended Land Pattern

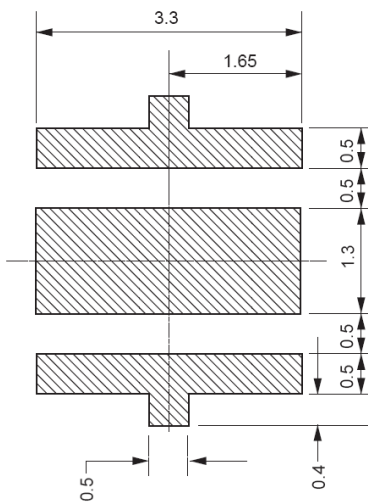

- * This LED has built-in ESD protection device(s) connected in parallel to LED Chip(s).
- * The thermal pad is electrically isolated from the anode and cathode contact pads.

6. Reliability Test Items and Conditions

1) Test Items and Results

Test Items	Test Conditions	Test Hours/Cycles
Room Temperature Life Test	25℃, DC 700 mA	1000 Hr
High Temperature humidity Life Test	85℃, 85%, DC 600 mA	1000 Hr
High Temperature Life Test	85℃, DC 600 mA	1000 Hr
Low Temperature Life Test	-40℃, DC 700 mA	1000 Hr
Temperature Humidity Cycle	-10℃ ↔ 25℃ 95%RH ↔ 85℃ 95%RH 350mA, 95%RH, 24hrs/1cycle	10 Cycles
Thermal Shock	-45 ℃/15 min ↔ 125 ℃/ 15 min. Temp.change within 5min.	200 Cycles
High Temperature Storage	Ta=120℃	1000 Hr
Low Temperature Storage	Ta=-40℃	1000 Hr
ESD(HBM)	R1=10MΩ, R2=1.5KΩ, C=100pF, V=±5KV, 5Times	5 Times (±5kV)

2) Criteria for Judging the Damage

Item	Symbol	Test Condition [T _a = 25℃]	Limit	
			Min.	Max.
Forward Voltage	V _F	350 mA	-	U.S.L. * 1.2
Luminous flux	Im	350 mA	L.S.L. * 0.7	-

* U.S.L. : Upper Standard Level L.S.L. : Lower Standard Level

7. Solder Conditions

1) Reflow Conditions (Pb Free)

Reflow Frequency : 2 times max.

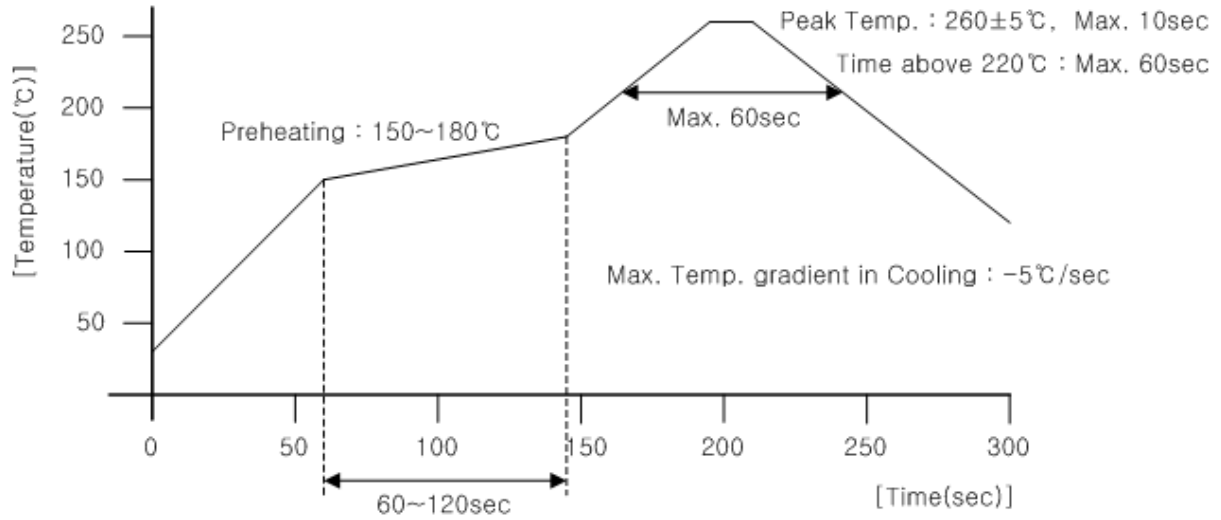

2) For Manual Soldering

Not more than 5 seconds @Max. 300°C, under soldering iron.

8. Taping Dimension

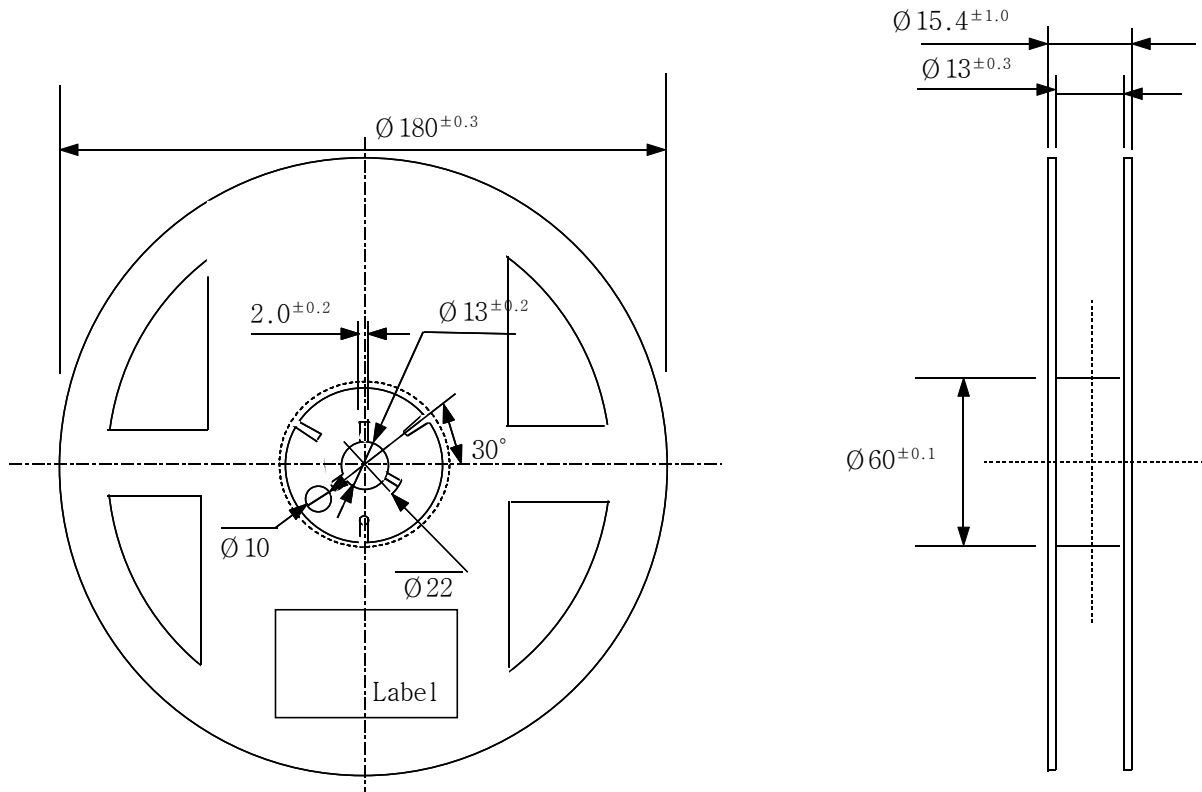
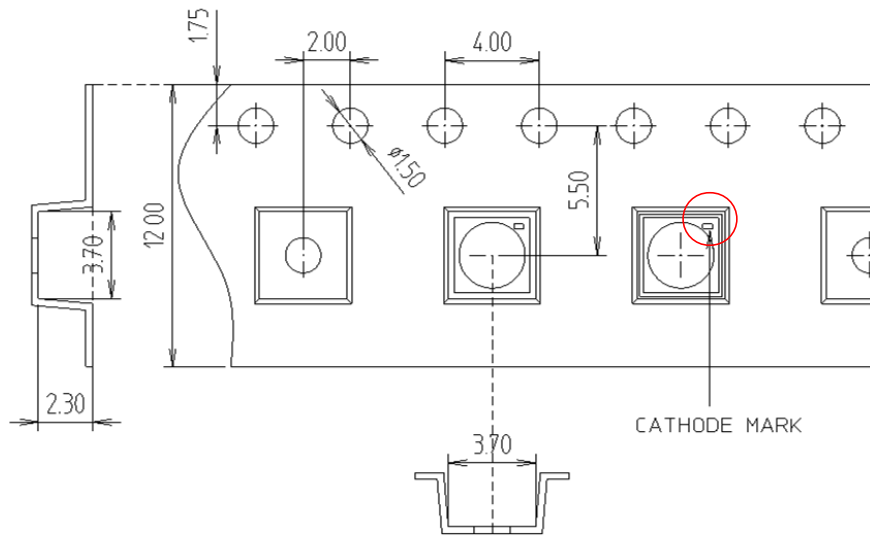

- (1) Quantity : The quantity/reel to be 1,000 pcs.
- (2) Cumulative Tolerance : Cumulative tolerance/10 pitches to be ± 0.2 mm
- (3) Adhesion Strength of Cover Tape : Adhesion strength to be 0.1-0.7N when the cover tape is turned off from the carrier tape at 10° angle to be the carrier tape.
- (4) Packaging : P/N, Manufacturing data code no. and quantity to be indicated on a damp proof package.

9. Label Structure

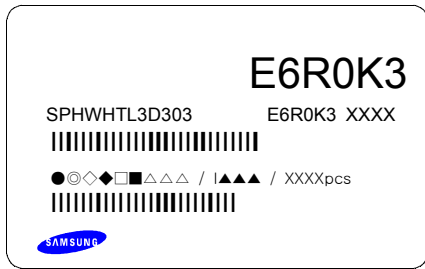

Rank Code

/E6/ : VF Rank (refer to page 5)

/R0/ : Chromaticity Coordinate Rank, CIE (refer to page 4)

/K3/ : Luminous Flux (refer to page 5)

10. Lot Number

The Lot number is composed of the following characters

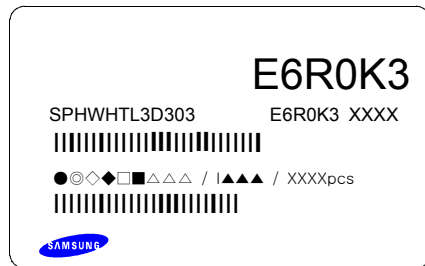

●◎◇◆□■△△△ / |▲▲▲ / 1000PCS

● : Production Site (S:SAMSUNG LED, G:Gosin China)

◎ : L (LED)

◇ : Product State (A:Normality, B:Bulk, C:First Production, R:Reproduction, S:Sample)

◆ : Year (S:2008, T:2009, U:2010...)

□ : Month (1 ~ 9, A, B)

■ : Day (1 ~ 9, A, B ~ V)

△ : SAMSUNG LED Product Number (1 ~ 999)

▲ : Reel Number (1 ~ 999)

11. Reel Packing Structure

Reel

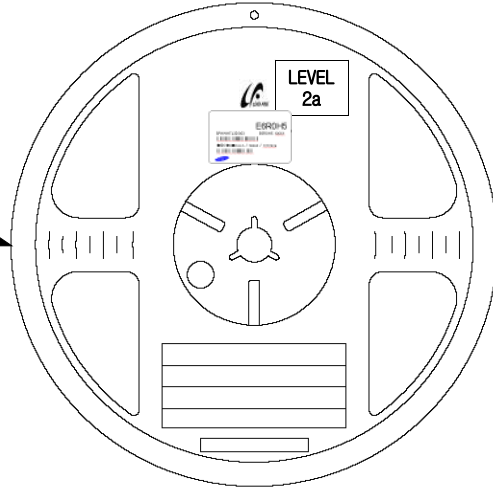
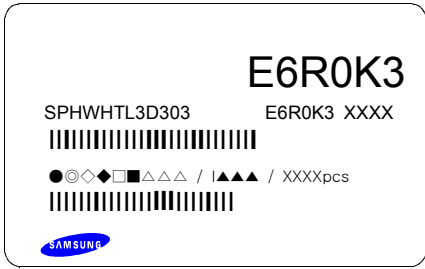

Aluminum Vinyl Bag

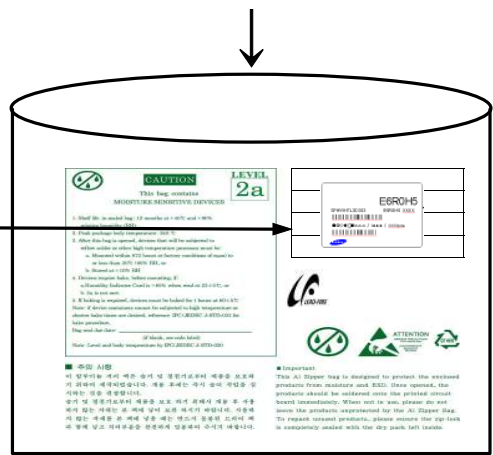
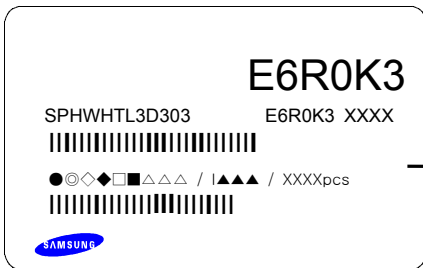

Material : Paper(SW3B(B))

TYPE	SIZE(mm)		
	a	b	c
7inch	250	225	190

① SIDE

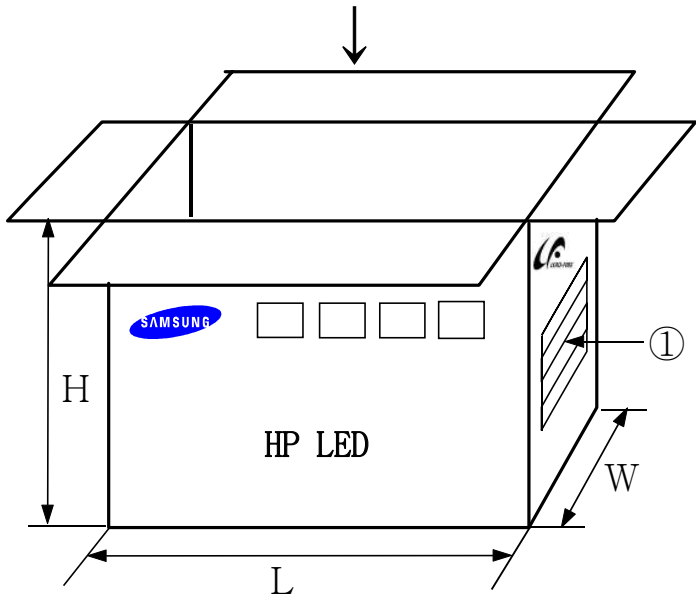
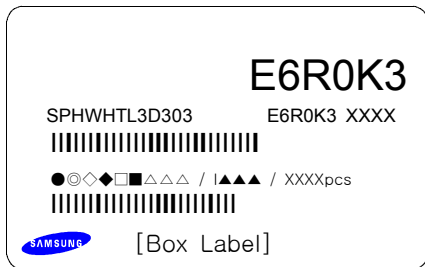

13. Precaution for use

- 1) For overcurrent-protection, customers are recommended to apply resistors connected in series with the LEDs to mitigate sudden change of the forward current caused by shift of the forward voltage.
- 2) This device should not be used in any type of fluid such as water, oil, organic solvent, etc. When cleaning is required, IPA is recommended as cleaning agent. Solvent-based cleaning agent such as Zestron^(R) may damage the silicone resins used in the device.
- 3) When the device is in operation, the forward current should be carefully determined considering the maximum ambient temperature and the corresponding junction temperature.
- 4) LEDs must be stored in a clean environment. If the LEDs are to be stored for 3 months or more after being shipped from Samsung LED, they should be packed with a nitrogen-filled container.
(Shelf life of sealed bags: 12 months, temp. 0~40°C, 20~70%RH)
- 5) After storage bag is open, device subject to soldering, solder reflow, or other high temperature processes must be:
 - a. Mounted within 168 hours (7 days) at an assembly line with a condition of no more than 30°C/60%RH.
 - b. Stored at <10% RH.
- 6) Repack unused Products with anti-moisture packing, fold to close any opening and then store in a dry place.
- 7) Devices require baking before mounting, if humidity card reading reaches 60% at 23±5°C.
- 8) Devices must be baked for 24hours at 65±5°C, if baking is required.
- 9) The LEDs are sensitive to the static electricity and surge current. It is recommended to use a wrist band or anti-electrostatic glove when handling the LEDs.
If voltage exceeding the absolute maximum rating is applied to LEDs, it may cause damage or even destruction to LED devices.
Damaged LEDs may show some unusual characteristics such as increase in leakage current, lowered turn-on voltage, or abnormal lighting of LEDs at low current.

14. Hazard Substance Analysis

**Test Report No.** F690501/LF-CTSAYAA11-02162

Issued Date: January 21, 2011

Page 1 of 5

To: **SAMSUNG LED CO., LTD.**
 314, Maetan-dong
 Yeongtong-gu
 Suwon-city
 GYEONGGI-DO 443-370
 Korea

The following merchandise was submitted and identified by the client as :

SGS File No. : AYAA11-02162
 Product Name : 3535 Ceramic PKG
 Item No./Part No. : N/A
 Received Date : Jan 18, 2011
 Test Period : Jan 19, 2011 to Jan 20, 2011
 Test Performed : SGS Testing Korea tested the sample(s) selected by applicant with following results
 Test Results : For further details, please refer to following page(s)
 Comments : By the applicant's specific request, the sampling and testing was performed only for the part indicated in the photo without disassembly.

Timothy Jeon
 Jinhee Kim
 Cindy Park
 Jerry Jung/ Testing Person

SGS Testing Korea Co. Ltd.

Jeff Jang / Chemical Lab Mgr

This document is issued by the Company, SGS, in its Standard Conditions of Service printed on the back of the report or available at www.sgs.com and, for electronic format documents, subject to Terms and Conditions for Electronic Documents at www.sgs.com.
 Signature is shown in the presence of a duly authorized and qualified person. Any notice or document is subject to the information contained therein, unless the Company declares at the time of its submission any and where the terms of Client's acceptance, if any. The Company will not be liable for any loss or damage, including consequential or indirect, arising from the use of the information contained in this document, even if advised of the possibility of such loss or damage. The information contained in this document is for the client's use only and is not to be used for any other purpose without the prior written consent of the Company. Any unauthorized alteration, copying or distribution of the content or reproduction of the document is strictly prohibited and may be prosecuted to the full extent of the law.
 Under no circumstances shall the results shown in this report be used for any other purpose than that for which they were intended and such results may be subject to 30 days only.

F052 Version3

SGS Testing Korea Co., Ltd

322, The O valley, 555-0, Hoggae-dong, Dongseo-gu, Anyang-si, Gyeonggi-do, Korea 431-000
 t +82 (0)31 4628 025 f +82 (0)31 4608 058 http://www.sgsfab.co.kr www.kr.sgs.com/greenlab

Member of the SGS Group (Société Générale de Surveillance)



Test Report No. F690501/LF-CTSAYAA11-02162

Issued Date: January 21, 2011

Page 2 of 5

Sample No. : AYAA11-02162.001
Sample Description : 3535 Ceramic PKG
Item No./Part No. : N/A
Comments : Materials are Ceramic, Silicone.

Heavy Metals

Test Items	Unit	Test Method	MDL	Results
Cadmium (Cd)	mg/kg	With reference to IEC 62321:2008, ICP	0.5	N.D.
Lead (Pb)	mg/kg	With reference to IEC 62321:2008, ICP	5	N.D.
Mercury (Hg)	mg/kg	With reference to IEC 62321:2008, ICP	2	N.D.
Hexavalent Chromium (Cr VI)	mg/kg	With reference to IEC 62321:2008, UV-VIS	1	N.D.

Flame Retardants-PBBs/PBDEs

Test Items	Unit	Test Method	MDL	Results
Monobromobiphenyl	mg/kg	With reference to IEC 62321:2008, GC-MS	5	N.D.
Dibromobiphenyl	mg/kg	With reference to IEC 62321:2008, GC-MS	5	N.D.
Tribromobiphenyl	mg/kg	With reference to IEC 62321:2008, GC-MS	5	N.D.
Tetrabromobiphenyl	mg/kg	With reference to IEC 62321:2008, GC-MS	5	N.D.
Pentabromobiphenyl	mg/kg	With reference to IEC 62321:2008, GC-MS	5	N.D.
Hexabromobiphenyl	mg/kg	With reference to IEC 62321:2008, GC-MS	5	N.D.
Heptabromobiphenyl	mg/kg	With reference to IEC 62321:2008, GC-MS	5	N.D.
Octabromobiphenyl	mg/kg	With reference to IEC 62321:2008, GC-MS	5	N.D.
Nonabromobiphenyl	mg/kg	With reference to IEC 62321:2008, GC-MS	5	N.D.
Decabromobiphenyl	mg/kg	With reference to IEC 62321:2008, GC-MS	5	N.D.
Monobromodiphenyl ether	mg/kg	With reference to IEC 62321:2008, GC-MS	5	N.D.
Dibromodiphenyl ether	mg/kg	With reference to IEC 62321:2008, GC-MS	5	N.D.
Tribromodiphenyl ether	mg/kg	With reference to IEC 62321:2008, GC-MS	5	N.D.
Tetrabromodiphenyl ether	mg/kg	With reference to IEC 62321:2008, GC-MS	5	N.D.
Pentabromodiphenyl ether	mg/kg	With reference to IEC 62321:2008, GC-MS	5	N.D.
Hexabromodiphenyl ether	mg/kg	With reference to IEC 62321:2008, GC-MS	5	N.D.
Heptabromodiphenyl ether	mg/kg	With reference to IEC 62321:2008, GC-MS	5	N.D.
Octabromodiphenyl ether	mg/kg	With reference to IEC 62321:2008, GC-MS	5	N.D.
Nonabromodiphenyl ether	mg/kg	With reference to IEC 62321:2008, GC-MS	5	N.D.
Decabromodiphenyl ether	mg/kg	With reference to IEC 62321:2008, GC-MS	5	N.D.

NOTE: (1) N.D. = Not detected.(<MDL)
 (2) mg/kg = ppm
 (3) MDL = Method Detection Limit
 (4) - = No regulation
 (5) ** = Qualitative analysis (No Unit)
 (6) * = Boiling-water-extraction:
 Negative = Absence of CrVI coating
 Positive = Presence of CrVI coating; the detected concentration in boiling-water-extraction solution is equal or greater than 0.02 mg/kg with 50 cm2 sample surface area.

This document is issued to the Company subject to its General Conditions of Service posted on its website or issued or available at www.sgs.com and, for electronic format documents, subject to Terms and Conditions for Electronic Documents at www.sgs.com/sgs_electronic_documents.htm. Attention is drawn to the limitation of liability, indemnification and limitation clause stated therein. Any holder of this document is advised that information contained therein reflects the Company's findings at the time of its issuance only and under the terms of Client's instructions, if any. The Company's sole responsibility is to its Client and this document does not constitute a contract or a guarantee from Samsung LED. All rights and obligations under the associated documents. This document cannot be reproduced, stored in a retrieval system or otherwise disseminated without the prior written approval of the Company. Any unauthorized alteration, copying or distribution of the content or appearance of this document is strictly prohibited and may be prosecuted under applicable laws.



Test Report No. F690501/LF-CTSAYAA11-02162

Issued Date: January 21, 2011

Page 3 of 5

Sample No. : AYAA11-02162.001
Sample Description : 3535 Ceramic PKG
Item No./Part No. : N/A
Comments : Materials are Ceramic, Silicone.

Halogen Contents

Test Items	Unit	Test Method	MDL	Results
Bromine(Br)	mg/kg	BS EN 14582:2007 , IC	30	N.D.
Chlorine(Cl)	mg/kg	BS EN 14582:2007 , IC	30	N.D.
Fluorine(F)	mg/kg	BS EN 14582:2007 , IC	30	N.D.
Iodine(I)	mg/kg	BS EN 14582:2007 , IC	50	N.D.

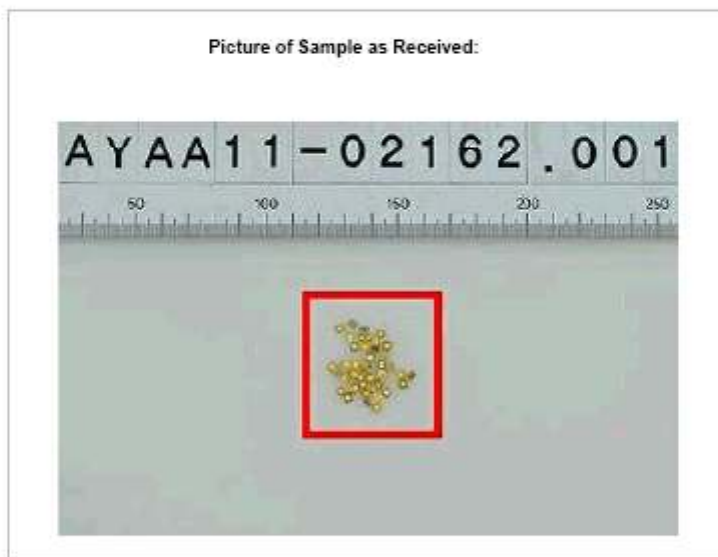

NOTE: (1) N.D. = Not detected.(<MDL)
 (2) mg/kg = ppm
 (3) MDL = Method Detection Limit
 (4) - = No regulation
 (5) ** = Qualitative analysis (No Unit)
 (6) * = Boiling-water-extraction:
 Negative = Absence of CrVI coating
 Positive = Presence of CrVI coating; the detected concentration in boiling-water-extraction solution is equal or greater than 0.02 mg/kg with 50 cm² sample surface area.

This document is issued by the Company which is its General Conditions of Service stated on website or issued or available at www.sgs.com and, for electronic format documents, subject to Terms and Conditions for Electronic Documents at www.sgs.com. Attention is drawn to the limitation of liability, indemnification and arbitration clause stated therein. Any failure of this document is subject and information contained herein reflects the Company's findings at the time of its issuance only and while the field of Client's possession, if any. The Company's sole responsibility is to its Client and the documents does not constitute a contract or a warranty. Your compliance with all laws and regulations under the jurisdiction documents. This document cannot be reproduced, except in full, without prior written approval of the Company. Any unauthorized alteration, forgery or falsification of the content or appearance of this document is strictly prohibited and may be prosecuted in the future. Please refer to the Terms and Conditions of Service on the Company's website for more details.

