

Agilent RCV1551 Fiber Optic “Light to Logic” Receiver

Data Sheet



Description

The RCV1551 receiver provides optical signal conversion and processing. It contains an InGaAs PIN photodiode and high sensitivity, wide dynamic range, transimpedance amplifier, capacitively coupled to limiting amplifier stages with PECL output drivers. Also provided is a loss of signal alarm.

The planar PIN photodiode operates throughout the 1200 nm to 1600 nm wavelength band. A bipolar wide dynamic range transimpedance amplifier optimized for 155 MBd operation provides low noise front end gain for the RCV1551.

A low pass filter maximizes the signal to noise ratio while minimizing intersymbol interference. The interface amplifier provides signal conversion and buffering for the PECL complementary data outputs. A complementary PECL alarm output is also provided.

The receiver operates in both ECL and PECL configurations. A 50/125 micron multimode fiber pigtail is included, assuring compatibility with multimode and single mode fiber optic systems.

Features

- Light to logic 20-pin DIP receiver offers ECL compatibility
- Long reach, high performance
- Sensitivity -36 dBm
- Single +5 V supply
- SONET/SDH compliant
- Multisourced

Applications

- Telecommunication networks
- SONET OC3 and SDH STM1 compatible
- Local and metropolitan area networks
- ATM single mode public network
- Military communications and control systems performance
- Digital cable TV networks



Agilent Technologies

Innovating the HP Way

Connection Diagram

Top View

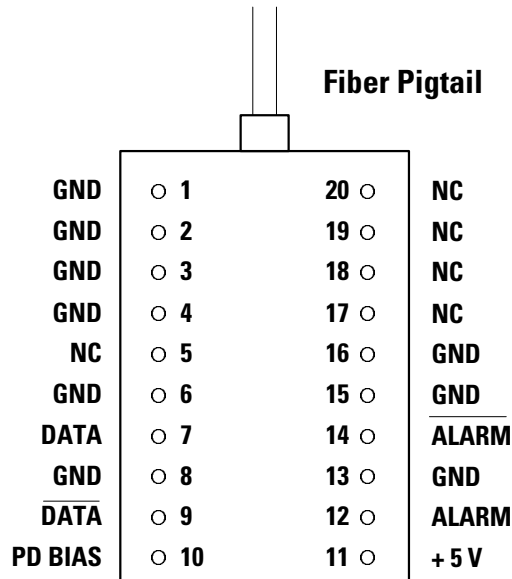

Pin Descriptions

Pins 5, 17, 18, 19, 20 NC:

These pins are not connected and should be left open circuit on the application PCB.

Pins 1, 2, 3, 4, 6, 8, 13, 15, 16 GND:

These pins should be connected to the circuit ground.

Pins 7, 9, DATA, DATA:

These pins provide complementary PECL DATA and $\overline{\text{DATA}}$ outputs. The DATA output is non inverting, an optical pulse causes the DATA output to go to the PECL logic high state (+4 V nominal).

Pin 10, PD Bias:

This pin must be connected to any voltage from 0 V (GND) to -6 V. This provides the photodiode bias. The current drawn is directly proportional to the average received photocurrent $I = \text{Responsivity} \times \text{Mean Power}$. The responsivity will be between 0.7 A/W and 1.0 A/W.

Pin 11, +5 V:

This pin should be connected to +5 V supply. The network shown below should be placed as close as possible to Pin 11.

Pins 12,14 ALARM, $\overline{\text{ALARM}}$:

These pins provide complementary differential ALARM and $\overline{\text{ALARM}}$ outputs. This is the low light alarm. ALARM goes to a logic low (3.3 V nominal) state when the optical power drops below the threshold level (insufficient optical power).

The optical power must increase to a higher level than the level where the alarm went low before ALARM will return to a logic high. This difference is the alarm hysteresis.

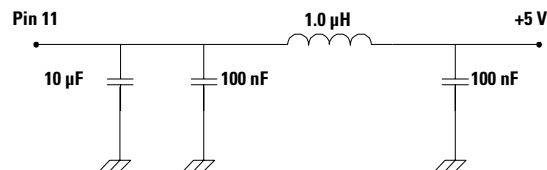

Functional Description

Design

The receiver contains an InGaAs photodetector, transimpedance amplifier and interface amplifier circuit. It is designed with a multimode fiber pigtail to allow maximum flexibility in connector options.

The interface amplifier is capacitively coupled to the preamplifier circuit.

Terminating the Outputs

The data outputs of the RCV1551 are PECL compatible. Care should be taken to match termination impedances to the interconnect to minimize reflection effects. Both serial data outputs (DATA and $\overline{\text{DATA}}$) should be terminated identically, even if only one output is used, in order to balance the drive currents drawn from the module. This will lower the power supply noise generated by the receiver and improve performance at low optical input power levels.

Power Supplies

The RCV1551 will operate to specifications with a single +5 V power supply (Pin 10 Grounded). The -5 V PIN bias is provided to maintain functional compatibility with second sources.

Circuit Layout

The RCV1551 uses very high bandwidth circuitry to achieve its high level of performance. Care must be taken to ensure stable operation. The use of ground planes and transmission line interconnects is required. The use of a standard evaluation board is highly recommended for those users who are not familiar with these techniques.

Signal traces should conform to ECL design rules to prevent reflections and ringing from degrading performance. Useful guidelines are contained in ECL manufacturer design manuals.

Manufacturing

The fiber pigtail on the device requires normal fiber handling considerations. Care should be taken to avoid tight bends as well as excessive tension on the fiber pigtail.

The allowable temperature range for the RCV1551 is limited by the material used in the pigtail. Exposure to temperatures over +85°C is not recommended. Low profile sockets or hand soldering are recommended for this part.

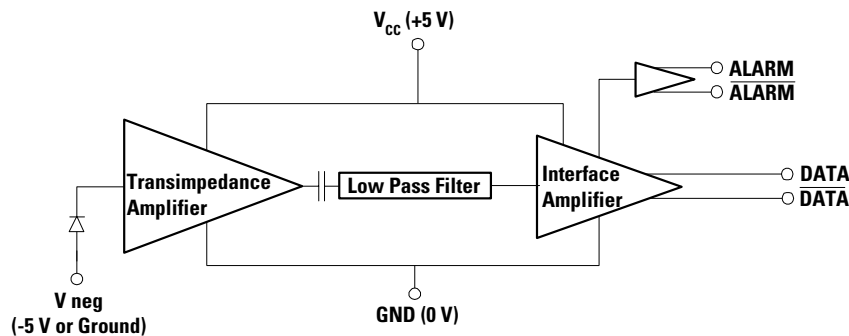

Figure 1. Block Diagram

Performance Specifications

Absolute Maximum Ratings

Stresses in excess of the absolute maximum ratings can cause catastrophic damage to the device. Limits apply to each parameter in isolation, all other parameters having values within the recommended operating conditions. It should not be assumed that limiting values of more than one parameter can be applied to the product at the same time. Exposure to the absolute maximum ratings for extended periods can adversely affect device reliability.

Parameter	Symbol	Minimum	Maximum	Units	Note
Supply Voltage	V _{CC}	-0.5	+5.5	V	1
Supply Voltage	V _{NEG}	-10	+0.5	V	-

Environmental Parameters

Parameter	Symbol	Minimum	Maximum	Units	Note
Operating Temperature	-	-40	+85	°C	-
Storage Temperature	-	-40	+85	°C	-
Humidity	-	-	85	%RH	-

Electrical Parameters (-40°C to +85°C)

Parameter	Symbol	Minimum	Maximum	Units	Note
Supply Voltage	V _{CC}	4.75	5.25	V	-
Supply Voltage	V _{NEG}	0	-6.0	V	-
V _{CC} Supply Current	-	-	150	mA	4
V _{NEG} Supply Current	-	-	1.0	mA	-
DATA Output Level (high)	-	3.8	4.15	V	2, 3
DATA Output Level (low)	-	3.1	3.5	V	2, 3
ALARM Output Level (high)	V _{OFF}	3.8	4.15	V	2, 3
ALARM Output Level (low)	V _{ON}	3.1	3.5	V	2, 3

Optical Parameters (-40°C to +85°C)

Parameter	Minimum	Maximum	Units	Note
Wavelength	1200	1600	nm	-
Receiver Sensitivity	-	-36	dBm	5
Maximum Input Power	0	-	dBm	-
Alarm ON	-45	-36	dBm	-
Hysteresis	0.5	4.0	dB	-
Alarm Response Time	-	600	μS	-

Fiber Pigtail	Typical	Units
Core Diameter	50	microns
Cladding Diameter	125	microns
Secondary Coating Diameter	900	microns

Notes:

1. V_{CC} of -0.5 V and V_{NEG} of +0.5 V may not be applied simultaneously.
2. Output terminated to (V_{CC} -2) with 50 Ω load or equivalent.
3. Output voltages are for V_{CC} = 5.0 V.
4. Outputs not loaded.
5. At a BER of 1 x 10⁻¹⁰, 2²³⁻¹ PRBS pattern NRZ data at the line rate with 10:1 extinction ratio. EOL.

Drawing Dimensions

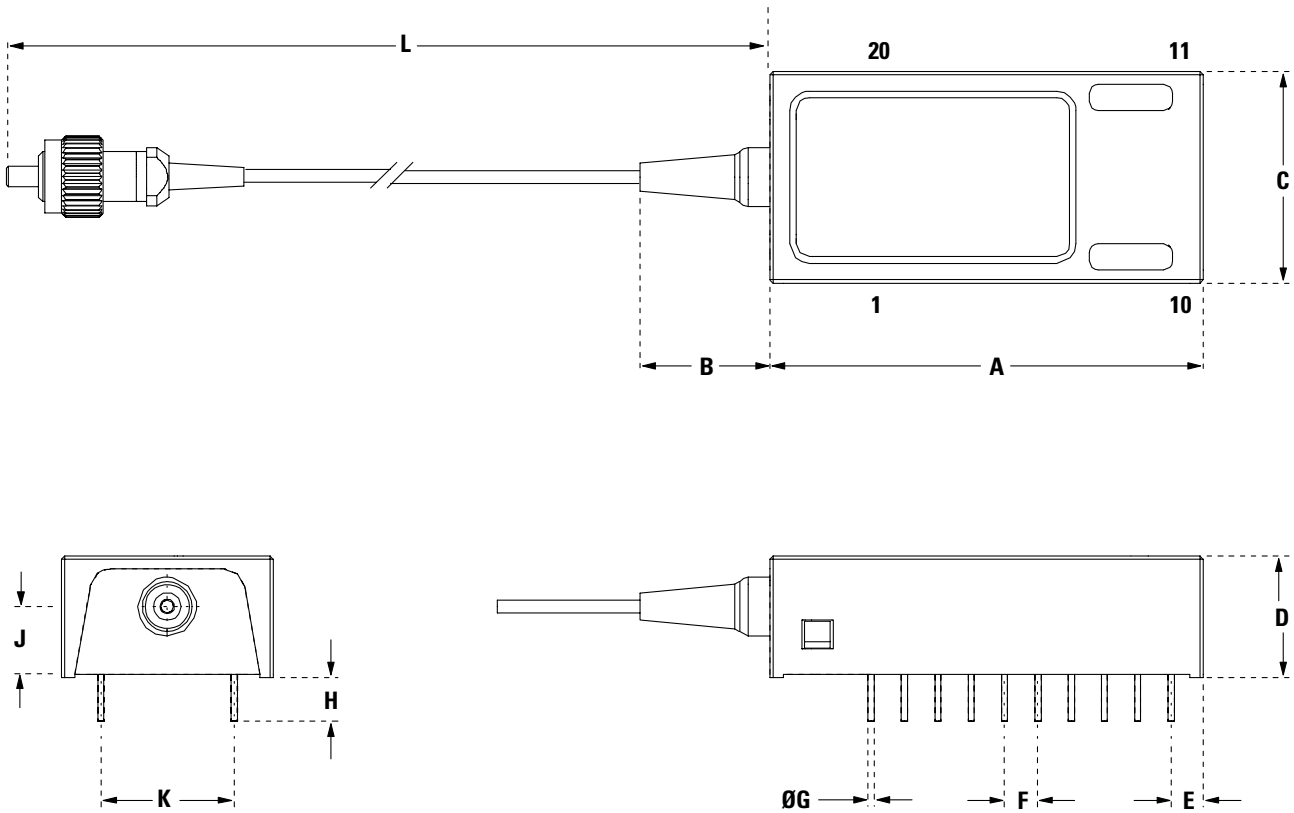

Dimension	Minimum	Nominal	Maximum
A	32.9	-	33.1
B	9.9	-	10.1
C	16.0	-	16.3
D	-	-	9.27
E	2.26	-	2.62
F	-	2.54	-
ØG	-	0.46	-
H	2.7	-	3.2
J	5.2	-	5.6
K	-	10.16	-
L	400	-	1220

All dimensions in mm

Ordering Information

RCV1551-xx

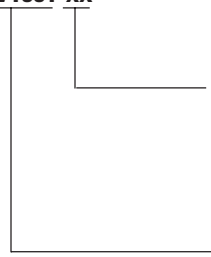

Connector:
FP = FC/PC Polish
ST = ST[®]
SC = SC

Model Name:
RCV1551

Allowable part numbers:

RCV1551-FP
RCV1551-ST
RCV1551-SC

Handling Precautions

1. The RCV1551 can be damaged by current surges or overvoltage.
Power supply transient precautions should be taken.
2. Normal handling precautions for electrostatic sensitive devices should be taken.

ST[®] is a Registered Trademark of AT&T

www.semiconductor.agilent.com

Data subject to change.

Copyright © 2000 Agilent Technologies, Inc.

Obsoletes: 5968-2455E

5988-0385EN (10/00)



Agilent Technologies

Innovating the HP Way