

Dual operational amplifier

BA4558 / BA4558F / BA4558N

The BA4558, BA4558F, and BA4558N are monolithic ICs with two operational amplifiers featuring low power consumption and internal phase compensation mounted on a single silicon chip. These products offer high speed, a wide band width, and low noise.

Outstanding thermal characteristics and voltage gain band width make these ICs ideal for use in a wide variety of electronic circuits. The BA4558 comes in an 8-pin DIP package and is compatible with the 4558 operational amplifier. The BA4558F comes in an 8-pin SOP package, and the BA4558N in an 8-pin SIP package.

●Applications

- Active filters
- Audio amplifiers
- VCOs
- Other electronic circuits

●Features

- 1) Low power dissipation of approximately 50mW (typ.).
- 2) Built-in output short-circuit protection circuit.
- 3) Internal phase compensation.
- 4) No latch-up.
- 5) Wide range of common mode and differential voltage.
- 6) High gain and low noise.

●Block diagram

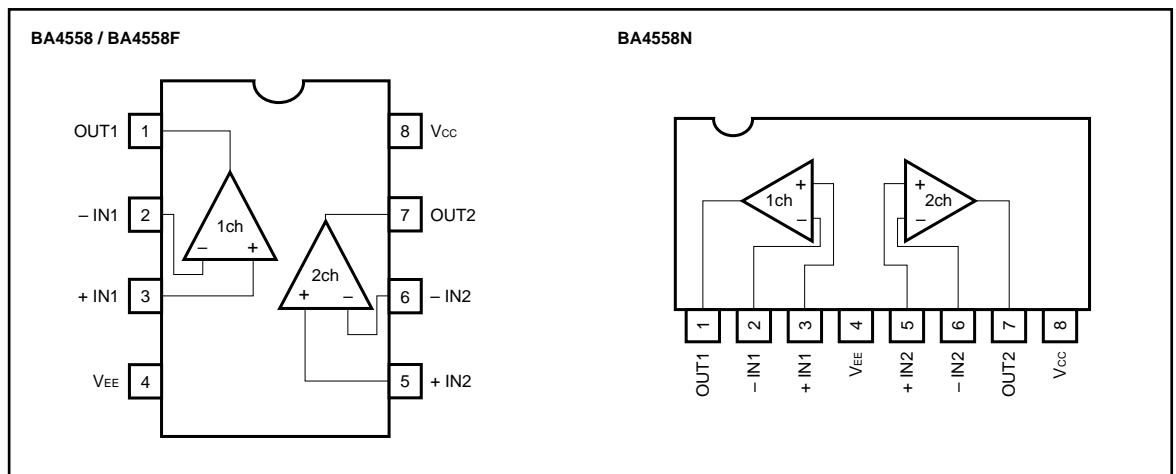

● Internal circuit configuration

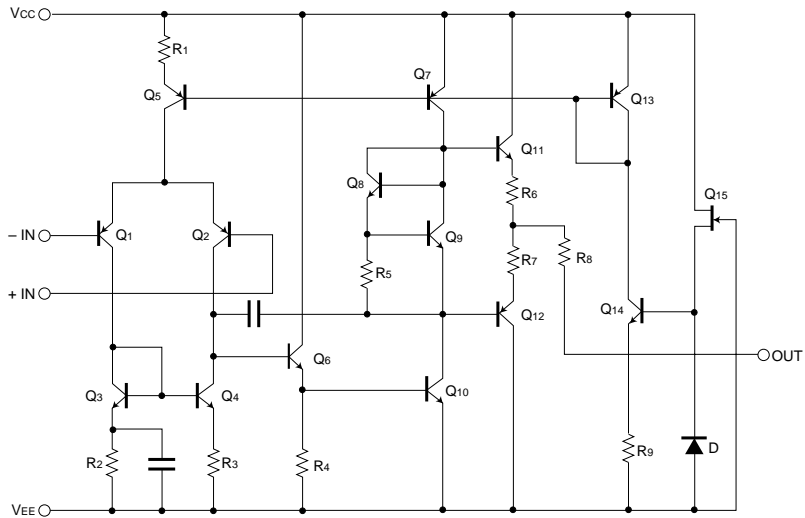

● Absolute maximum ratings (Ta = 25°C)

Parameter	Symbol	Limits			Unit
		BA4558	BA4558F	BA4558N	
Power supply voltage	V _{cc}	± 18	± 18	± 18	V
Power dissipation	P _d	800*	550*	900*	mW
Differential input voltage	V _{ID}	± 30	± 30	± 30	V
Common-mode input voltage	V _I	± 15	± 15	± 15	V
Operating temperature	T _{opr}	- 40 ~ + 85	- 40 ~ + 85	- 40 ~ + 85	°C
Storage temperature	T _{stg}	- 55 ~ + 125	- 55 ~ + 125	- 55 ~ + 125	°C

* Refer to P_d characteristics diagram.

The values for the BA4558F are those when it is mounted on a glass epoxy board (50mm × 50mm × 1.6mm).

●Electrical characteristics (unless otherwise noted, $T_a = 25^\circ\text{C}$, $V_{CC} = +15\text{V}$, $V_{EE} = -15\text{V}$)

Parameter	Symbol	Min.	Typ.	Max.	Unit	Conditions
Input offset voltage	V_{IO}	—	0.5	6.0	mV	$R_s \leq 10\text{k}\Omega$
Input offset current	I_{IO}	—	5	200	nA	
Input bias current	I_B	—	60	500	nA	
High-amplitude voltage gain	A_v	86	100	—	dB	$R_L \cong 2\text{k}\Omega$, $V_O = \pm 10\text{V}$
Common-mode input voltage	V_{ICM}	± 12	± 14	—	V	
Maximum output voltage	V_{OH}	± 12	± 14	—	V	$R_L \cong 10\text{k}\Omega$
Minimum output voltage	V_{OL}	± 10	± 13	—	V	$R_L \cong 2\text{k}\Omega$
Common-mode rejection ratio	CMRR	70	90	—	dB	$R_s \leq 10\text{k}\Omega$
Power supply voltage rejection ratio	PSRR	—	30	150	$\mu\text{V}/\text{V}$	$R_s \leq 10\text{k}\Omega$
Slew rate	S.R.	—	1.0	—	$\text{V}/\mu\text{s}$	$A_v = 1$, $R_L \cong 2\text{k}\Omega$
Channel separation	CS	—	105	—	dB	$f = 1\text{kHz}$

●Electrical characteristic curves

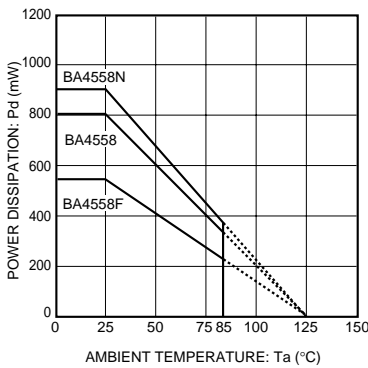

Fig.1 Power dissipation vs. ambient temperature

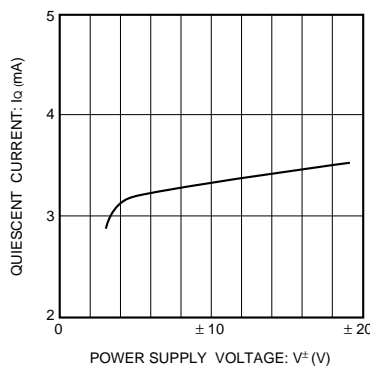

Fig.2 Quiescent current vs. power supply voltage

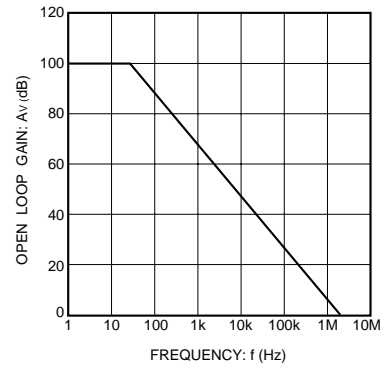

Fig.3 Open loop voltage gain vs. frequency

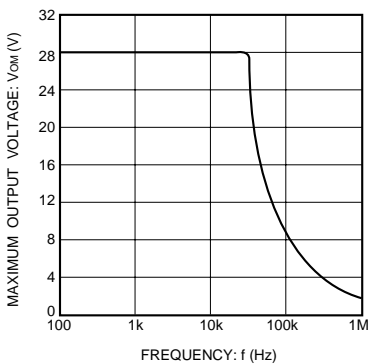

Fig.4 Maximum output voltage vs. frequency

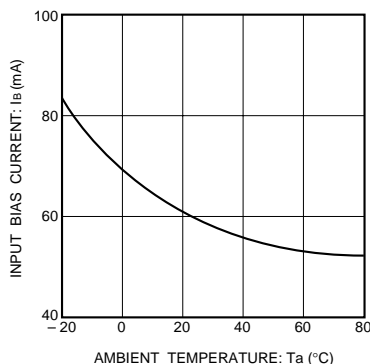

Fig.5 Input bias current vs. ambient temperature

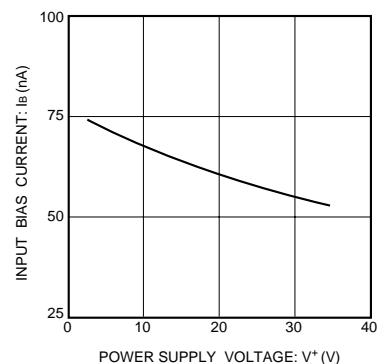

Fig.6 Input bias current vs. power supply voltage

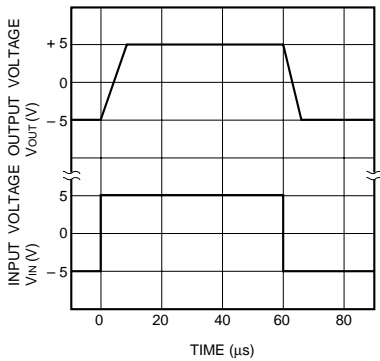

Fig.7 Output response characteristics

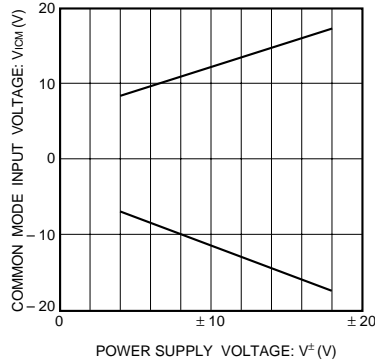

Fig.8 Common mode input voltage vs. power supply voltage

● Operation notes

(1) Unused circuit connections

If there are any circuits which are not being used, we recommend making connections as shown in Figure 9, with the non-inverted input pin connected to the potential within the in-phase input voltage range (V_{ICM}).

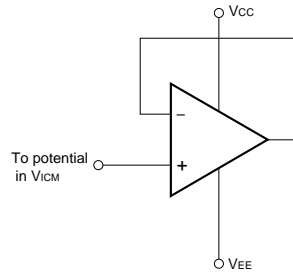
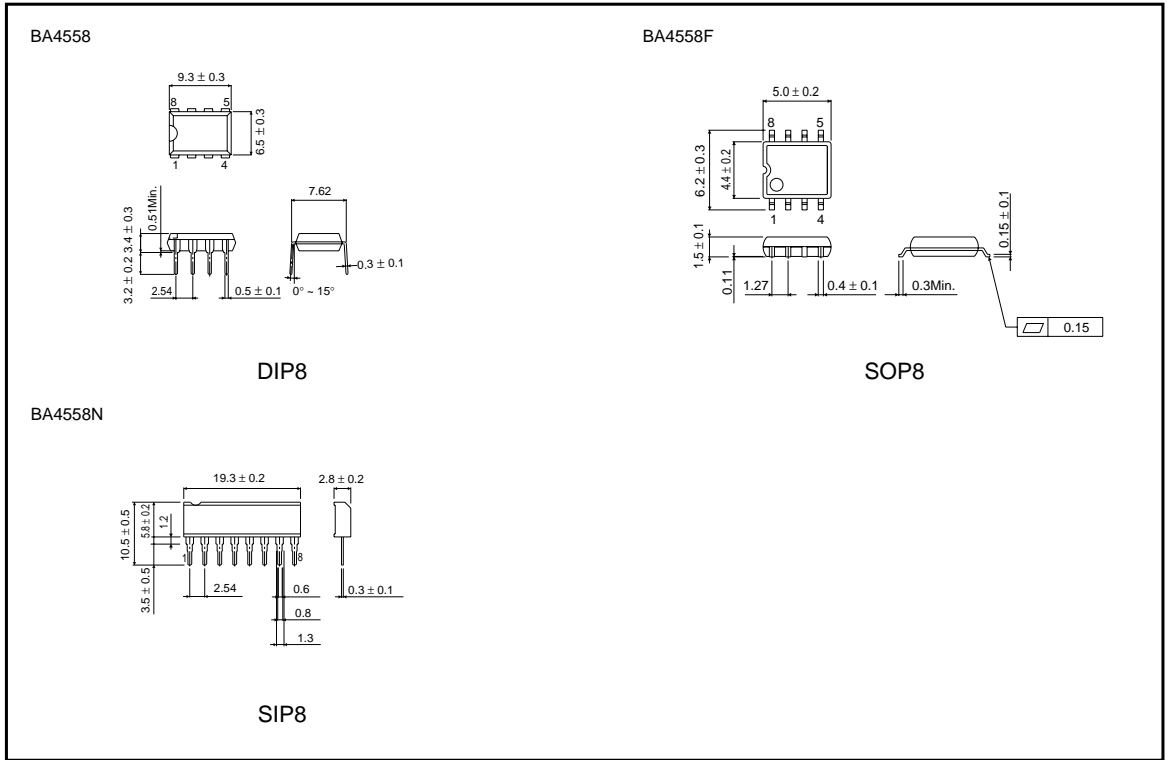

Fig.9 Unused circuit connections

● External dimensions (Units: mm)



Notes

- No technical content pages of this document may be reproduced in any form or transmitted by any means without prior permission of ROHM CO.,LTD.
- The contents described herein are subject to change without notice. The specifications for the product described in this document are for reference only. Upon actual use, therefore, please request that specifications to be separately delivered.
- Application circuit diagrams and circuit constants contained herein are shown as examples of standard use and operation. Please pay careful attention to the peripheral conditions when designing circuits and deciding upon circuit constants in the set.
- Any data, including, but not limited to application circuit diagrams information, described herein are intended only as illustrations of such devices and not as the specifications for such devices. ROHM CO.,LTD. disclaims any warranty that any use of such devices shall be free from infringement of any third party's intellectual property rights or other proprietary rights, and further, assumes no liability of whatsoever nature in the event of any such infringement, or arising from or connected with or related to the use of such devices.
- Upon the sale of any such devices, other than for buyer's right to use such devices itself, resell or otherwise dispose of the same, no express or implied right or license to practice or commercially exploit any intellectual property rights or other proprietary rights owned or controlled by
- ROHM CO., LTD. is granted to any such buyer.
- Products listed in this document use silicon as a basic material.
Products listed in this document are no antiradiation design.

The products listed in this document are designed to be used with ordinary electronic equipment or devices (such as audio visual equipment, office-automation equipment, communications devices, electrical appliances and electronic toys).

Should you intend to use these products with equipment or devices which require an extremely high level of reliability and the malfunction of which would directly endanger human life (such as medical instruments, transportation equipment, aerospace machinery, nuclear-reactor controllers, fuel controllers and other safety devices), please be sure to consult with our sales representative in advance.

About Export Control Order in Japan

Products described herein are the objects of controlled goods in Annex 1 (Item 16) of Export Trade Control Order in Japan.

In case of export from Japan, please confirm if it applies to "objective" criteria or an "informed" (by MITI clause) on the basis of "catch all controls for Non-Proliferation of Weapons of Mass Destruction.