

CA3052**Four Independent AC Amplifiers**

Special-Function Sub-System for Stereo Preamplifiers,
Magnetic Pickups, Tape Heads, etc.

Features:

- Four AC amplifiers on a common substrate
- Independently accessible inputs and outputs
- Operates from single-ended supply

- Output impedance - 1 k Ω typ.
- Open-loop bandwidth - 300 kHz typ.

EACH AMPLIFIER

- High voltage gain - 53 dB min.
- High input resistance - 90 k Ω typ.
- Undistorted output voltage - 2 V rms min.

The RCA-CA3052 is a silicon monolithic integrated circuit designed specifically for stereo preamplifier service. The circuit consists of four independent ac amplifiers which can operate from a single-ended supply.

The CA3052 can operate as an equalizer amplifier in tape recorders, magnetic cartridge phonograph applications, and tone control amplifiers. It can provide all of the amplification necessary for a full-function stereo preamplifier.

The CA3052 is supplied in a 16-lead dual-in-line plastic package.

Applications:

- Full-function stereo preamplifiers
- Tape recorder and playback preamplifiers
- Tone generators

RCA-CA3052 is schematically identical with the CA3048 Amplifier Array (File No. 377). Each amplifier of the CA3048 is tightly specified for equivalent output noise under a variety of test methods. The CA3052 is specified using RIAA test methods for equivalent input noise using one test method for amplifiers 1 and 4, and an appropriately different method for amplifiers 2 and 3.

ABSOLUTE-MAXIMUM RATING at $T_A = 25^\circ\text{C}$:**DISSIPATION:**

Up to $T_A = 55^\circ\text{C}$	750 mW
Above $T_A = 55^\circ\text{C}$	Derate linearly at 7.7 mW/ $^\circ\text{C}$

TEMPERATURE RANGE:

Operating	-40 $^\circ\text{C}$ to +85 $^\circ\text{C}$
Storage	-65 $^\circ\text{C}$ to +150 $^\circ\text{C}$

LEAD TEMPERATURE (During Soldering):

At distance 1/16 \pm 1/32 inch (1.59 \pm 0.79 mm) from case for 10 seconds max.	+265 $^\circ\text{C}$
---	-----------------------

POWER SUPPLY VOLTAGE +16 V

AC INPUT VOLTAGE 0.5 V rms

File Number **387**

MAXIMUM VOLTAGE RATINGS

The following chart gives the range of voltages which can be applied to the terminals listed vertically with respect to the terminals listed horizontally. For example, the voltage range between vertical terminal 2 and horizontal terminal 4 is +2 to -3.6 volts.

TERMI- NAL No.	1	2	3	4	5	6	7	8	9	10	11	12	13	14	15	16
1		+16 0	*	*	*	*	*	*	*	*	*	*	*	*	0 -16	*
2			*	+2 -3.6	0	*	*	+2 -3.6	+2 -3.6	*	*	+16 0	+2 -3.6	*	+16 0	0 -16
3				+5 -5	*	*	*	*	*	*	*	*	*	*	*	*
4					+3.6 -2	*	*	*	*	*	*	*	*	*	*	*
5						0 -16	*	+2 -3.6	+2 -3.6	*	0 -16	+16 0	+2 -3.6	*	+16 0	*
6							*	*	*	*	*	*	0 -16	*	*	*
7								+5 -5	*	*	*	*	*	*	*	*
8									*	*	*	*	*	*	*	*
9										+5 -5	*	*	*	*	*	*
10											*	*	*	*	*	*
11												*	*	*	*	*
12													0 -16	*	*	*
13														+5 -5	*	*
14															*	*
15																+16 0
16																

* Voltages are not normally applied between these terminals. Voltages appearing between these terminals will be safe if the specified limits between all other terminals are not exceeded.

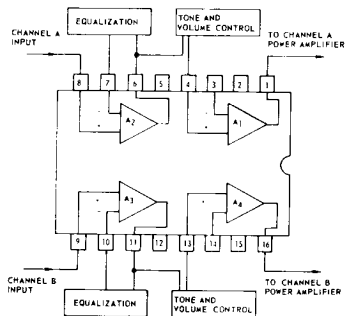

Fig. 1 - Block diagram of stereo preamplifier using CA3052.

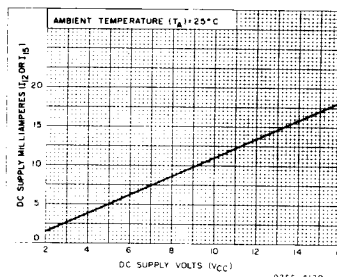

Fig. 2 - Typical DC supply current vs supply voltage.

CA3052

ELECTRICAL CHARACTERISTICS at $T_A = 25^\circ\text{C}$

CHARACTERISTICS	SYMBOLS	TEST CONDITIONS	LIMITS CA3052			UNITS
			MIN.	TYP.	MAX.	
STATIC						
Current drain per amplifier pair	I_{12} or I_{15}	$V_{CC} = +12\text{ V}$	9.5	13.5	17.5	mA
DC Voltage at Output Terminals	$V_1, V_6,$ V_{11}, V_{16}	$V_{CC} = +12\text{ V}$	6.1	6.9	8.1	V
DC Voltage at Feedback Terminals	$V_3, V_7,$ V_{10}, V_{14}	$V_{CC} = +12\text{ V}$	1.7	2.0	2.3	V
DC Voltage at Input Terminals	$V_4, V_8,$ V_9, V_{13}	$V_{CC} = +12\text{ V}$	2.2	2.5	2.8	V
DYNAMIC each amplifier with no AC feedback unless otherwise noted—terminals 3, 7, 10, & 14 bypassed to ground						
Open-Loop Gain	A_{OL}	$V_{CC} = +12\text{ V}$ $E_{IN} = 2\text{ mV}$ $f = 10\text{ kHz}$	53	58	—	dB
Open-Loop Output Voltage Swing	$V_O(\text{rms})$	$V_{CC} = +12\text{ V}$ $f = 1\text{ kHz}$ THD = 5%	2.0	2.4	—	V
Open-Loop -3 dB Bandwidth	BW	$V_{CC} = +12\text{ V}$ $E_{IN} = 2\text{ mV}$	—	300	—	kHz
Open-Loop Total Harmonic Distortion	THD	$V_{CC} = +12\text{ V}, f = 1\text{ kHz}$ $E_{OUT} = 2\text{ V rms}$	—	0.65	—	%
Input Resistance	R_I	$V_{CC} = +12\text{ V}, f = 1\text{ kHz}$	—	90	—	$k\Omega$
Input Capacitance	C_I	$V_{CC} = +12\text{ V}, f = 1\text{ MHz}$	—	9	—	pF
Output Resistance	R_O	$V_{CC} = +12\text{ V}, f = 1\text{ kHz}$	—	1	—	$k\Omega$
Feedback Capacitance (Output to non-inverting Input)	C_{FB}	$V_{CC} = +12\text{ V}$ $f = 1\text{ MHz}$	—	< 0.1	—	pF
Equivalent Input Noise Voltage (Amplifiers 1 & 4), "C" Filter at Output*	$E_{NI}\ddagger$	$V_{CC} = +10\text{ V}$ $R_S = 5\text{ k}\Omega$ $A = 45\text{ dB}$	—	1.7	6.4	μV
Equivalent Input Noise Voltage (Amplifiers 2 & 3) RIAA Compensated*	$E_{N2}\ddagger$	$V_{CC} = +10\text{ V}$ $R_S = 5\text{ k}\Omega$ $A = 64\text{ dB (1 kHz)}$	—	4	15.0	μV
Inter-Amplifier Audio Separation "Cross Talk" ¹¹		$V_{CC} = +12\text{ V}$ $f = 1\text{ kHz}$ 0 dB = 0.78 V	—	< -45	—	dB
Inter-Amplifier Capacitance (Any amplifier output to any other amplifier input)	C	$V_{CC} = +12\text{ V}$ $f = 1\text{ MHz}$	—	< 0.02	—	pF

*Per IHF Standard Methods of Measurement for Audio Amplifiers IHF-A-201, 1966

‡ ac feedback included in test circuit

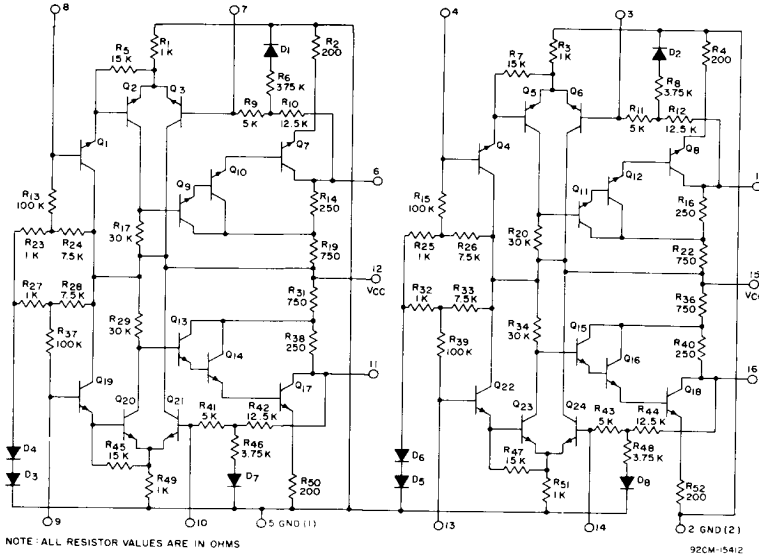

Fig. 3 - Schematic diagram for CA3052.

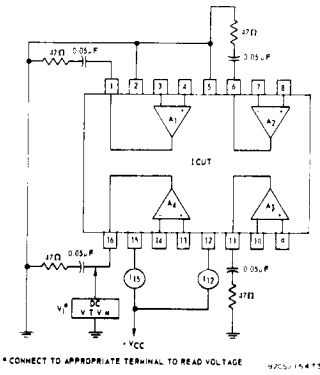

Fig. 4 - Test circuit for measurement of collector supply voltage and currents.

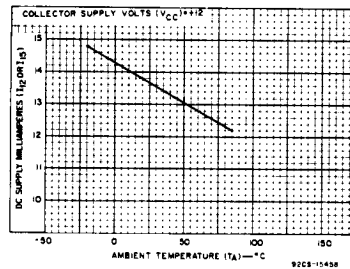
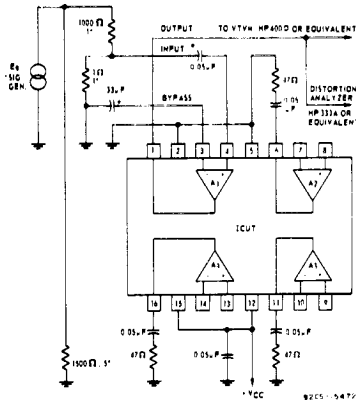

Fig. 5 - Typical DC supply current vs ambient temperature.

CA3052



- * Sig Gen should be a low distortion type (0.2% THD or less) HP206A or equivalent.
- Adjustment of E_g to 2 volts will make $E_o = 2$ mV.
- Test Circuit shows Amplifier #1 under test, to test Amplifiers 2, 3, or 4, Connect terminals as shown in Table.

AMPLIFIER	TERMINALS		
	OUTPUT	INPUT	BYPASS
1	1	4	3
2	6	8	7
3	11	9	10
4	16	13	14

Fig. 6 — Test circuit for measurement of distortion, open-loop gain, and bandwidth characteristics.

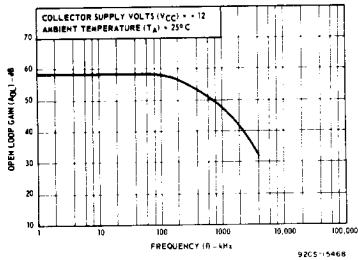

Fig. 9 — Typical open-loop gain vs frequency.

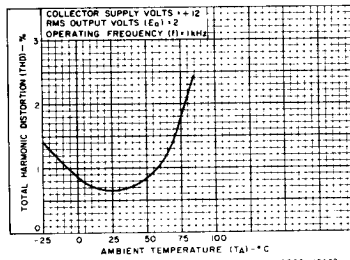

Fig. 10 — Typical total harmonic distortion vs ambient temperature.

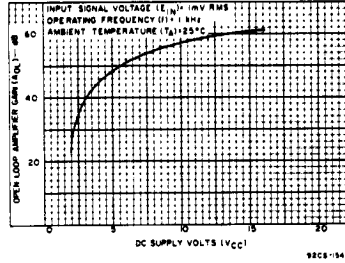

Fig. 7 — Typical amplifier gain vs DC supply voltage.

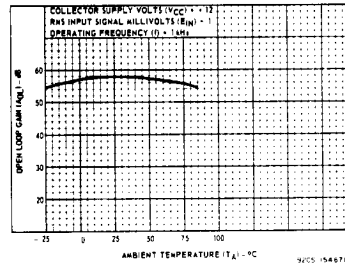
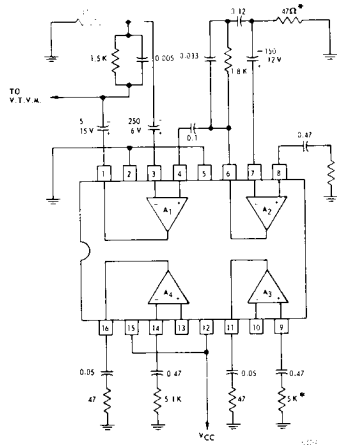
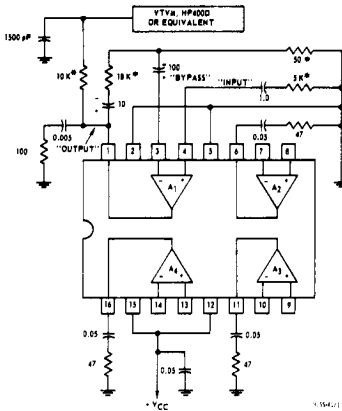

Fig. 8 — Typical open-loop gain vs ambient temperature.



*Resistors are low noise precision (1%) Metal Film type.
Fig. 11 — Test circuit for equivalent input noise voltage measurement, RIAA compensated.



*Resistors are low noise precision, (1%) Metal Film type. Resistor values are in ohms; capacitance values are in microfarads, unless otherwise specified.

Fig. 12— Test circuit for measurement of equivalent input noise voltage of amplifiers 1 and 4.

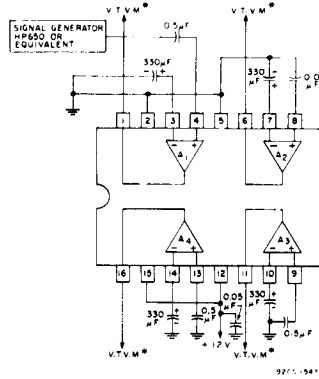

*V.T.V.M. - Hewlett-Packard Model 400D or equivalent.
Procedure:
 1. Adjust Signal Generator for 0 dB output at reference terminal.
 2. Read voltage at other output terminals (Figure shows terminal #1 used as reference).

Fig. 13 — Test circuit for measurement of inter-amplifier audio separation "cross talk" characteristic.

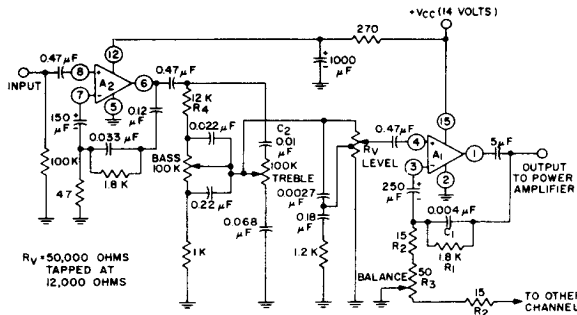

Performance Data

Gain at 1-kHz reference	47 dB
Boost at 100 Hz	11.5 dB
Boost at 10 kHz	11.5 dB
Cut at 100 Hz	10 dB
Cut at 10 kHz	9 dB

Noise:

- At maximum volume (input shorted) > 70 dB below 1 volt
- At minimum volume > 80 dB below 1 volt
- Total harmonic distortion (at 1-kHz reference and an output of 1 volt) < 0.3 per cent

92CM-29305

Fig. 14 - Schematic of one channel of a complete stereo preamplifier.

CA3052

OPERATING CONSIDERATIONS

Economical Gain Control

The CA3052 is designed to permit flexibility in the methods by which amplifier gain can be controlled. Fig. 15 shows a curve of the gain of an amplifier when the internal resistive feedback of the device is used in conjunction with an external resistor. Although measured gain of various amplifiers will not be uniform, because of tolerances of internal resistances, this method is very economical and easy to apply.

Stability

The CA3052, as in other devices having high gain-band-width product, requires some attention to circuit layout, design, and construction to achieve stability.

Should the CA3052 be left unterminated, socket capacitance alone will provide sufficient feedback to cause high frequency oscillations; therefore, all test circuits in this data bulletin include loading networks that provide stability under all conditions.

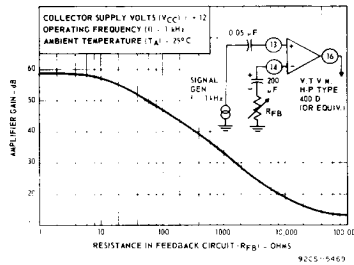

Fig. 15 — Typical amplifier gain vs feedback resistance.