



FS453/4 and FS455/6 Data Sheet Guides

To make specialized information easier to find, the FS453/4 and FS455/6 Data Sheet is organized into separate reference guides. Each guide addresses a different purpose or user.

- The ***FS453/4 and FS455/6 Product Brief*** provides general information for all users.

- The ***FS453/4 and FS455/6 Hardware Reference*** is for system designers. It provides information on developing FS453/4 and FS455/6 applications. (This section now includes ***PCB Layout Guide***)

- The ***FS453/4 and FS455/6 Software/Firmware Reference*** is for programmers. It provides information on programming the FS453/4 and FS455/6.

If you need additional reference guides, contact your Focus Enhancements representative.

Throughout this document "FS453" is used as a general term to reference the FS453, FS454, FS455, and FS456. The FS453 and FS454 are the PQFP versions of the chip, and the FS455 and FS456 are the BGA versions of the chip. The FS454 and FS456 support Macrovision anti-copy protection, while the FS453 and FS455 do not.

Table of Contents, Figures & Tables

Document Overview	3	9.1.1 Power	30
1. Introduction	4	9.1.2 Ground	31
1.1 General Description	4	9.2 DIGITAL SIGNALS	31
1.2 How does it work?	4	9.2.1 Digital Signal Routing	31
1.2.1 SDTV Output	4	9.2.2 Video Inputs	32
1.2.2 HDTV Output	4	9.3 ANALOG SIGNALS	32
1.2.3 VGA (RGB) Output	4	9.3.1 Video Output Filters	32
1.3 General Physical Requirements	4	9.4 CLOCK/OSCILLATOR	34
2. Architectural Overview	5	9.4.1 Reference Crystal Oscillator	34
2.1 Inputs	5	9.4.2 FS453 Pixel Clock	34
2.1.1 Input to Output Conversion Matrix	6	9.4.3 Pixel Clock Mode	35
2.2 Color Space Converter	6	9.5 EMI Case Study	37
2.3 Patented 2D Scaler	6	9.6 Solder Re-flow Profiles	38
2.4 Patented 2D Flicker Filter	7	10. Revision History	40
2.5 FIFO	7	11. Order Information	41
2.6 Post (Horizontal Up) Scaler	7	Figure 1: FS453 Functional Block Diagram	5
2.7 Encoder and Inverse Color Space	7	Figure 2: FS453 Scaler Luma Frequency Response	9
2.8 Bi and Tri-Level Sync Insertion (HDTV)	7	Figure 3: FS453 Flicker Filter Diagonal Response	10
2.9 Configurable 10 bit DACs	7	Figure 4: Equations for VTOTAL and VSC	12
2.10 Clock Management	7	Figure 5: VTOTAL and VACTIVE ratios must match	12
2.11 Oscillators and PLL	7	Figure 6: HSC Equations	13
2.12 Serial Control Interface	8	Figure 7: PQFP Pin Diagram	14
2.13 Sync Timing Generator	8	Figure 8: FBGA Pin Diagram	15
2.14 Input Synchronization	8	Figure 9: PQFP Package Outline & Dimensions	28
3. Technical Highlights	9	Figure 10: FBGA Package Outline & Dimensions	29
3.1 Scaling	9	Figure 11: Recommended Power Filter Networks	31
3.1.1 Video Scaler Challenges	9	Figure 12: Recommended Output Filter	33
3.1.2 FS453 Solution	9	Figure 13: Pixel Clock Pseudo-master Mode	36
3.2 Flicker Reduction	10	Figure 14: Pixel Clock Slave Mode	36
3.2.1 Flicker Filter Challenges	10	Figure 15: PQFP Package (Lead Solder)	38
3.2.2 FS453 Solution	10	Figure 16: FBGA Package (Lead Solder)	39
3.3 Video Encoding	11	Figure 17: PQFP or FBGA Package (Lead-Free Solder)	39
3.3.1 Encoding Challenges	11	Table 1: Input to Output Conversion Matrix	6
3.3.2 FS453 Solution	11	Table 2: FS453 PQFP Pin Assignments	14
4. Scaling and Positioning Notes	12	Table 3: FS453 to GCC Pin Mapping	16
4.1 Vertical Scaling	12	Table 4: FS453 Pin Descriptions	20
4.2 Horizontal Scaling	13	Table 5: Register Reference Table	23
4.3 Vertical and Horizontal Position	13	Table 6: Absolute Maximum and Recommended Ratings	24
5. Pin Assignments	14	Table 7: Electrical Characteristics	26
5.1 FS453 ↔ GCC Pin Mapping	16	Table 8: Switching Characteristics	27
5.2 Pin Descriptions	17	Table 9: Package Dimensions	28
6. Control Register Function Map	21	Table 10: Output Filter Component Values	34
6.1 Register Reference Table	21		
7. Specifications	24		
7.1 Absolute Maximum and Recommended Ratings	24		
7.2 Electrical Characteristics	25		
7.3 Switching Characteristics	27		
8. Mechanical Dimensions	28		
8.1 80-Lead PQFP Package	28		
8.2 88-Lead FBGA Package	29		
9. Component Placement	30		
9.1 Power/Ground	30		

Document Overview

The Hardware Reference provides information needed to integrate the FS453 Video Processor into system hardware. The reference is divided into eight sections:

1. **Introduction** – explains the purpose and general flow of the FS453. *Begins on page 4.*
2. **Architectural Overview** – defines the major sections of the FS453 and describes how they work together. *Begins on page 5.*
3. **Technical Highlights** – explains technical challenges faced by scan converters, and explains how the FS453 accomplishes Scaling, Flicker Filtering, and Video Encoding. *Begins on page 9.*
4. **Scaling and Positioning Notes**– provides more detailed information on how the FS453 performs Scaling and Positioning. *Begins on page 12.*
5. **Pin Assignments** – lists the pin names and maps their correspondence to sample host graphics controller chips. Describes pin functions. *Begins on page 14.*
6. **Control Register Function Map** – lists the Control Register functions and register numbers. If you need more information about the Control Registers, please request a copy of the **FS453/4 and FS455/6 Software / Firmware Reference** from your Focus Enhancements representative. *The Control Register Function Map begins on page 21.*
7. **Specifications** – provides information on the Absolute Maximum and Recommended Ratings, the Electrical Characteristics, and the Switching Characteristics. *Begins on page 24.*
8. **Mechanical Dimensions** – describes the FS453's 80-lead PQFP and 88-lead FBGA packages. *Begins on page 28.*
9. **Component Placement** – gives guidelines for the placement and layout of components associated with the FS453. *Begins on page 30.*

1. Introduction

1.1 General Description

The FS453 PC to TV Video Scan Converter provides broadcast-quality scan conversion for graphics cards, motherboard chip sets, video game consoles, consumer electronics and other PC-to-TV applications. Compatible with most graphics controller chips (GCC), the FS453 takes in high-resolution computer graphics input (VGA through SXGA) and produces SDTV (Standard Definition Television) or HDTV (High Definition Television) analog output. In SDTV mode the FS453 converts, scales, removes flicker, interlaces and encodes the data into NTSC or PAL formats. In HDTV mode, it performs color space conversions and then inserts the required syncs for output. The FS453's patented technology enables it to scale the converted image to fill the TV screen and display flicker-free graphics with sharply defined text.

1.2 How does it work?

The FS453 provides a glueless digital interface to most GCCs. It accepts computer-generated digital graphics input in RGB or YCrCb format. The FS453 receives initialization and basic configuration information through its I²C*-compatible SIO port with simple register Read/Write commands. How the FS453 actually processes and converts the graphics information depends on the kind of video output selected. (Refer to Figure 1: FS453 Functional Block Diagram on page 5.)

1.2.1 SDTV Output

For example, to create SDTV output the FS453 first changes RGB video to YCrCb. It uses patented technology to scale (in other words, to proportionately increase or decrease) the number of video lines and pixels per line to correspond to the specific SDTV standard. This allows the FS453 to precisely fill the user's television screen without adding artifacts such as blank areas, or distorting the graphics image. The FS453 uses more patented technology to adaptively remove the flicker effects common to SDTV while keeping fine detail (such as text) clear and sharp. The FS453 then encodes the processed image into broadcast quality, interlaced SDTV video and sends it out through the DACs. For European SCART output, the FS453 converts the image into RGB video and sends the R, G and B signals through separate DACs.

1.2.2 HDTV Output

To convert high-resolution computer graphics to high resolution HDTV output the FS453 converts the digital video (whether RGB or YCrCb format) to YPrPb (analog component video). It adds Bi- and Tri-Level Syncs as required by the selected standard and routes the analog HDTV video through the DACs.

1.2.3 VGA (RGB) Output

The FS453 can also provide VGA output. In this mode, it allows the GCC's RGB images to pass unchanged directly through to the DACs. The HSync and VSync signals must be driven by the GCC.

1.3 General Physical Requirements

Implementing the FS453 in your system will require very few components – just a 27 MHz clock and passive parts. The FS453 uses an 80-lead Quad Flat Pack (PQFP) or an 88-lead Fine-pitch Ball Grid Array (FBGA) package and requires power from +1.8V digital and +3.3V analog supplies.

*Note: I²C is a registered trademark of Philips Corporation. The FS453 Serial I/O bus is similar but not identical to the Philips I²C bus.

2. Architectural Overview

The FS453 has the following major sections:

- Inputs P[23:0]
- Programmable Color Space Converter
- Patented 2D (Horizontal and Vertical) Scaling
- Patented 2D Flicker Filter
- FIFO
- Post (Horizontal Up) Scaler
- Inverse Color Space
- Broadcast Quality Encoder
- HDTV Bi- & Tri-Level Sync Insertion
- Configurable 10 bit DACs
- Clock Management
- Oscillators and PLL
- Serial Control Interface
- Sync Timing Generator

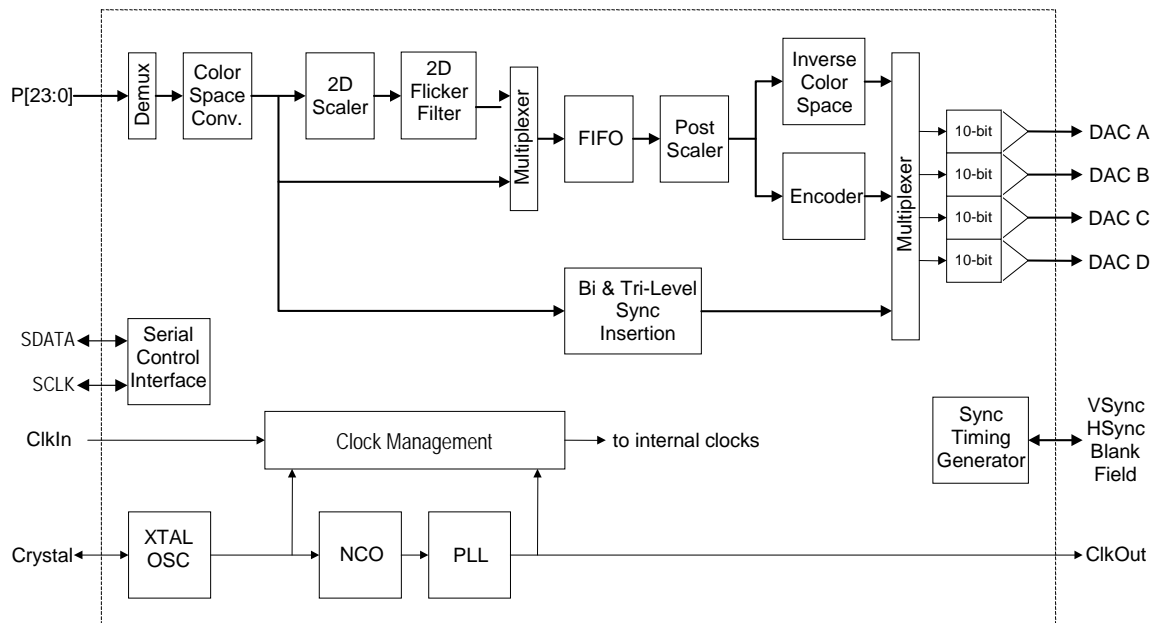

Figure 1: FS453 Functional Block Diagram

2.1 Inputs

The FS453 accepts computer graphics images in many different resolutions and pixel frequencies on P[23:0]. The FS453 adaptively process this information for optimal display on SDTV and HDTV television sets.

2.1.1 Input to Output Conversion Matrix

Table 1 below lists some commonly used input modes and the correspondingly supported output modes. SDTV input dimensions are completely configurable, subject only to pixel clock range limitations.

Input Configuration		Output Configuration				
		SDTV		HDTV		
Pixels	Lines	NTSC @59.94Hz	PAL @50Hz	480p @60Hz	720p @60Hz	1080i @60Hz
640 - 720	480	*	*	* ^(a)		
640 - 720	576	*	*			
800	600	*	*			
1024	768	*	*			
1280	720	* ^(b)	* ^(b)		* ^(a)	
1920	1080					* ^(c)

Table 1: Input to Output Conversion Matrix

Notes:

- (a) No scaling supported
- (b) Subject to the maximum 150 MHz pixel rate
- (c) No scaling or interlacing supported, input data must be interlaced

2.2 Color Space Converter

The programmable Color Space Converter receives either RGB or YCrCb data from the input port. If the data is RGB, it is converted to YCrCb using programmable coefficients. Each of the Y, Cr, and Cb components can then be independently scaled in amplitude with programmable multipliers. This programmability supports both SDTV and HDTV color space matrices.

2.3 Patented 2D Scaler

The Patented 2D Scaler receives data from the Color Space Converter. It performs vertical (up or down) scaling based on the value programmed in the VSC (Vertical Scaling Coefficient) register, offset 06h. It performs horizontal (down) scaling based on the downscale value programmed in the HSC (Horizontal Scaling Coefficient) register, offset 08h.

Because different video standards call for different numbers of lines and different numbers of pixels per line, scan converters add or subtract lines and areas to fit graphics images onto different sizes of TV screens. Most scan converters use simple line-dropping algorithms and fixed aspect ratios. Unfortunately, these techniques can introduce shape-distorting artifacts and surround the actual image with blank areas.

The FS453, however, uses patented technology that can scale the graphics image without creating artifacts. The patented 2D Scaler can independently upscale or downscale an image in both the horizontal (pixels) and vertical (lines) directions. Its scaling functions provide equal weight to all pixels and lines in the source material for all scaling factors. This allows users to perfectly fit the graphics image to their TV screens without adding scaling artifacts or large blank borders.

2.4 Patented 2D Flicker Filter

The Patented 2D Flicker Filter receives video lines from the 2D Scaler and performs vertical filtering to reduce or eliminate perceived flicker that is an artifact of the interlaced television format.

The FS453's flicker filter is significantly more effective than a typical three-line-average flicker filter. The FS453's flicker filter consists of joint horizontal (Sharpness) and vertical (Flicker) controls. Three-line-average flicker filters do reduce the visual effect of interlaced image flicker, but they also introduce blurring. The flicker dimension of the FS453's filter reduces image flicker, while the sharpness dimension of the FS453's filter reduces image blurring. Both the sharpness and flicker registers can be programmed over a wide range of values to allow the user to customer tailor the filter settings to different display devices.

2.5 FIFO

The Flicker Filter stores video data in a FIFO memory. This memory allows the video data to be transferred from the graphics clock domain to the TV clock domain.

2.6 Post (Horizontal Up) Scaler

The Post Scaler draws information from the FIFO as necessary and scales it horizontally based on the up-scale value programmed in the Horizontal Scaling Coefficient (HSC) register. The scaled data is provided at the television clock rate to the SDTV video encoder and the Inverse Color Space.

2.7 Encoder and Inverse Color Space

The FS453 contains a broadcast quality, 2X oversampled video encoder with an Inverse Color Space matrix. The encoder combines the chrominance, luminance, and timing information into broadcast quality NTSC or PAL composite and YC (S-Video) signals and sends them to the DACs.

The Inverse Color Space transforms YCrCb video data to the RGB color space required for SCART output. If the Inverse Color Space is not used, then the Encoder converts YCrCb to YPrPb as required for SDTV YPrPb output. The RGB or YPrPb signals are sent to the DACs synchronized with the Encoder's composite signal.

The FS454 and FS456, which are otherwise identical to the FS453 and FS455, respectively, incorporate Macrovision 7 anti-copy protection in the encoder. The FS454 and FS456 also include 480p protection.

2.8 Bi and Tri-Level Sync Insertion (HDTV)

The FS453 also offers HDTV Syncs output modes. The color matrix, output level, and sync type are fully programmable allowing for compatibility with the multiple HDTV standards. The FS453 inserts bi-level or tri-level sync signals as defined by the standards.

2.9 Configurable 10 bit DACs

The four output DACs (Digital/Analog Converters) can be configured for several output formats: RGB component output (VGA); RGB with CVBS (SCART); CVBS (2 optional) and Y/C (S-Video); and YPrPb component output (HDTV or SDTV). To conserve power the DACs can be run in low power mode or can be completely powered down when not in use.

2.10 Clock Management

The FS453 synthesizes a 0.78125-150 MHz clock from the 27 MHz XTAL_IN and supplies this clock (CLKOUT) to the GCC. The clock is buffered and returned to the FS453 (CLKIN_P) synchronous to the pixel data and sync information. This clock has a 1.5 Hz resolution and can be adjusted so that the GCC scaled input data rate exactly matches the ITU-R BT.656 output data rate.

2.11 Oscillators and PLL

The FS453 clock generation circuit operates in one of two modes, NCO (Numerically Controlled Oscillator) mode or PLL (Phase Locked Loop) mode. In NCO mode, the numerically controlled oscillator

is used to achieve the finest clock resolution, using a dithered clock. In PLL mode, the NCO is bypassed and the clock is not dithered. The NCO can be used when HTOTAL and VTOTAL values have additional constraints that prevent selection of values that are factors of the TV pixel rate.

2.12 Serial Control Interface

The FS453 registers are accessed through a serial input/output bus (SIO) which is I²C*-compatible and SMBus-compatible. These registers can be read or written at any time the part is receiving a reference clock at XTAL_IN and not being held in reset via the RESET_L pin.

2.13 Sync Timing Generator

The Sync Timing Generator provides/accepts HSync, VSync, Field and Blank signals to/from the graphics controller.

2.14 Input Synchronization

The FS453 can operate in pseudo-master mode or slave mode. In pseudo-master mode, the GCC derives the VGA pixel clock, horizontal sync, and vertical sync from CLKOUT supplied by the FS453. In slave mode, the GCC generates the pixel clock, syncs and data, and the FS453 must be programmed to generate the same pixel clock, using a common reference. Use the slave mode when the GCC does not have a pixel clock input.

*Note: I²C is a registered trademark of Philips Corporation. The FS453 Serial I/O bus is similar but not identical to the Philips I²C bus.

3. Technical Highlights

Creating clear, broadcast quality television video from high resolution computer graphics is a complex process. PC-to-TV Video Scan Converters have to surmount many technical obstacles. The most challenging of these are scaling, flicker reduction, and encoding.

3.1 Scaling

Converting high-resolution computer images into relatively low-resolution TV images (such as converting VGA or XGA images into NTSC standard definition television) is an inherently lossy process that requires a video scaler. For example, converting an image with 1000 pixels in a line into an image with only 500 pixels in a line, means that there must be 50% less data in each line of output. The video scaler has to perform its tasks effectively without further degrading the image.

3.1.1 Video Scaler Challenges

Therefore, in addition to reducing pixel count and interpolating pixel values, the scaler must not alter the digital video data by adding artifacts. Examples of artifacts are the introduction of repeated pixels; the complete loss of pixel data; and the creation of new pixel colors that are not interpolations of original pixel colors.

In effect, the video scaler should behave like a high quality filter. It should have a gradual frequency roll off with a good step response and little overshoot or ringing (less than 5%). This is ideal for maintaining video quality with detailed images (such as text). Detailed images produce rapid output step transitions that need to be executed cleanly.

3.1.2 FS453 Solution

The following diagram (Figure 2) illustrates the response of the FS453's video scaler. It is a normalized plot of the Luma frequency response of the FS453's video scaler. As we can see, the FS453's patented video scaler behaves like a high quality filter with only a gradual frequency roll off.

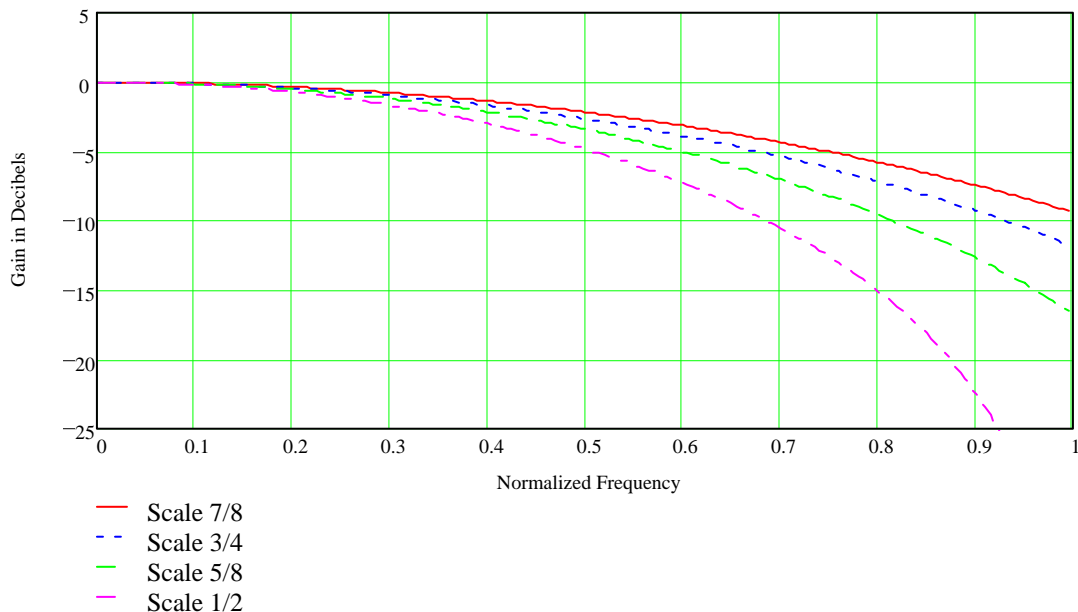

Figure 2: FS453 Scaler Luma Frequency Response

3.2 Flicker Reduction

Computer images are displayed progressively. That is, for a given frame of video, each line of video is scanned onto the monitor sequentially. SDTV images, however, are interlaced. Each SDTV frame of video is broken into two fields (one composed of odd lines and the other of even lines). First the odd lines are scanned onto the TV, and then the even lines are scanned onto the TV.

The energy decay rate of the phosphors on a TV screen is fast enough that the older field of video will appear somewhat dimmer than the newer field of video. As the fields are constantly changing, this can result in a visible flicker between the two fields of data on the TV screen. This flicker is especially visible when one field contains a long dark line, while an adjacent line (in the other field) contains a long white line. The higher energy line will decay in brightness much faster than the low energy line, and in turn will appear to flicker heavily.

Most scan converters simply average the pixel data between lines. This removes the Black-or-White relationships between lines that viewers recognize as video flicker. The problem with this solution is that data becomes blurred. Single black or white lines are reduced to grays. Detailed areas of video (such as the gap in the letter 'e') lose their distinction.

3.2.1 Flicker Filter Challenges

The goal is to completely remove flicker from the image without blurring detailed video. To preserve the video details, the flicker filter should have a flat frequency response (± 1 dB) between pixels in the horizontal, and diagonal directions. It must also avoid introducing new artifacts into the digital video stream. Artifacts include repeating pixels, losing pixels; and creating colors that are not interpolations of original pixel colors.

3.2.2 FS453 Solution

The FS453 uses a patented flicker filter that calculates output pixel values as a function of both vertical (line averaging) and horizontal (pixel averaging) pixel relationships. In effect the FS453 can decide where and how to reduce flicker within the image.

Figure 3 (below) shows a normalized plot of the frequency response of pixels along diagonal after being processed by the FS453's flicker filter. The response is flat for the majority of the frequency space. This maintains pixel sharpness while providing excellent flicker suppression.

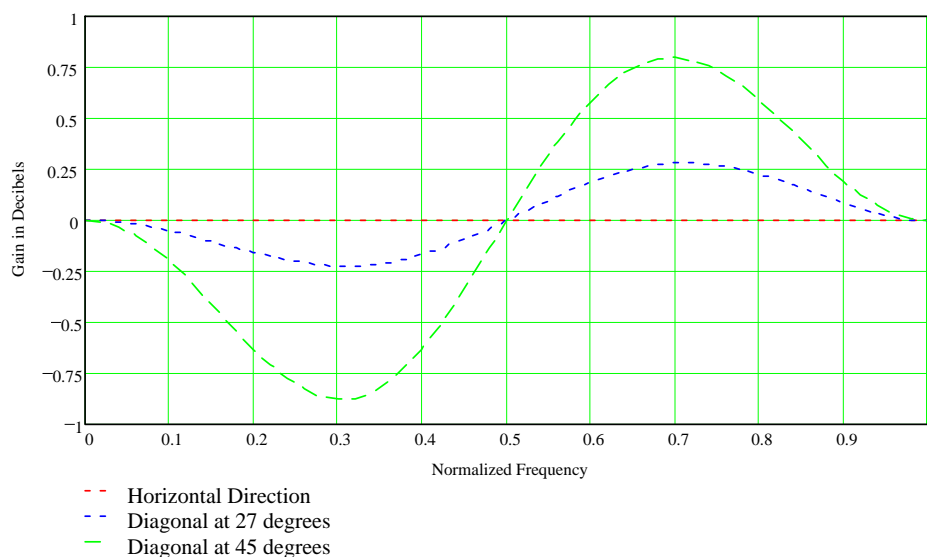

Figure 3: FS453 Flicker Filter Diagonal Response

3.3 Video Encoding

Unlike component video formats (PC and HDTV) that process the color information separately to avoid interference, broadcast SDTV combines all picture information into a single, composite signal. SDTV standards have been strictly defined to protect video quality and to allow television manufacturers to design and build large volumes of systems with confidence that their signal decoders will work—regardless of variances in final product tolerances.

3.3.1 Encoding Challenges

If a video encoder does not adhere closely to these standards, it may produce video artifacts on many consumer televisions. Unfortunately, most scan converters use signal encoders that don't strictly follow NTSC and PAL guidelines. Their encoders can increase artifacts such as chroma crawl and color bleeding/smearing.

To meet broadcast quality a video encoder must comply with the NTSC (EIA-170A, SMPTE-170M) and PAL (ITU-R624-3) standards in all modes. Of key importance are the specifications related to accurate timing and signal amplitudes, video subcarrier frequency good to +/- 5Hz, and horizontal lock with zero SC-H phase. The encoder must use a low jitter crystal (50 ppm) to drive DAC output directly. The DACs should have 10 bits of resolution, and exhibit good differential gain and differential phase characteristics. The video encoder must be able to pre-filter composite video (CVBS) to prevent luma(Y)/chroma(C) cross talk.

3.3.2 FS453 Solution

The FS453 features a broadcast quality encoder. It uses tunable Y-notch and C-bandpass filters to prevent the creation of video artifacts and to meet all specifications. The FS453's encoder subcarrier is programmable in frequency and phase. Because of the encoder's independence of color format, vertical sync, and number of lines, the FS453 is able to support many SDTV video standards, including all of the South American variations. The FS453 can output NTSC M, J and PAL B, D, G, H, I, M, N, Combination N, and PAL-60 formats with 10 bits of resolution. Both Composite and S-Video outputs are available simultaneously. In addition to encoded PAL or NTSC, the user may select analog SCART RGB outputs. Each channel of RGB has 10 bits of resolution. Note that the 10-bit DACs exceed the bit depth supported by the 8-bits available at the FS453 input.

4. Scaling and Positioning Notes

The FS453 graphics converter does not use a frame memory. Therefore, the FS453 input video frame rate must be synchronous to and match the output video field or frame rate. In SDTV modes, the FS453 uses internal line memories in order to perform horizontal and vertical scaling. This imposes certain requirements on the scale and position settings.

4.1 Vertical Scaling

Because the frame/field rates are synchronous, and no frame memory is available, the ratios of input to output VTOTAL and input to output VACTIVE must match. (See Figure 4 below.) In this sense, the output VACTIVE is not necessarily the total active lines of the selected TV standard, but is the number of TV lines that will contain active video information from the input source material. If the output VACTIVE value is smaller than the value specified by the TV standard, then the FS453 will place borders and below the image. TV_VTOTAL and GCC_VACTIVE in the VTOTAL equation are determined by the selected TV standard and graphics mode. TV_VACTIVE is selected to set the desired number of TV lines containing video information. The Vertical Scaling Coefficient is programmed in register 06h. The ratio of input to output VTOTAL also determines the vertical scaling factor used. Note that calculations are done using the output *frame* size, even though the output is interlaced, because interlacing is done after vertical scaling.

$$\text{GCC_VACTIVE} / \text{GCC_VTOTAL} = \text{TV_VACTIVE} / \text{TV_VTOTAL}$$

For downscaling, $\text{VSC} = (\text{TV_VTOTAL} / \text{GCC_VTOTAL}) * 65,536$
 For upscaling, $\text{VSC} = (\text{TV_VTOTAL} / \text{GCC_VTOTAL} - 1) * 65,536$

Figure 4: Equations for VTOTAL and VSC

Notes:

- GCC_VACTIVE: The number of active lines of computer graphics in a frame.
 GCC_VTOTAL: The total number of lines in a computer graphics frame, including active and blanking.
 TV_VACTIVE: The number of lines in a TV video frame that will contain scaled graphics data.
 TV_VTOTAL: The total number of lines in a TV video frame. PAL has 625 lines. NTSC has 525 lines.

For example, consider a case where the input graphics active area contains 600 lines and the selected TV standard is NTSC. In NTSC, TV_VTOTAL is 525 lines per frame and the full-size active area is 487 lines per frame. To program the FS453 to scale the GRAPHICS image to fit on 400 lines of TV video (for example, to fit the image within the TV bezel), set TV_VACTIVE to 400. This sets three of the four parameters in the equation, and solving for VGA_VTOTAL results in a value of 787.5. Because values must be integers, set VGA_VTOTAL to 788. The scaled image will still occupy approximately 400 lines. Given these VTOTAL values, the vertical scaling factor is 0.6662, and the VSC register will be set to 43,663 (0xAA8F).

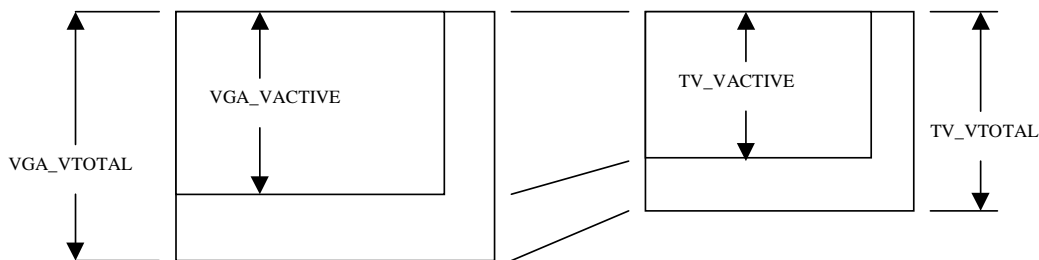

Figure 5: VTOTAL and VACTIVE ratios must match

4.2 Horizontal Scaling

While vertical scaling is linked to the VTOTAL ratio, horizontal scaling is arbitrary and not linked to HTOTAL at all. The horizontal scaler is simply programmed with the ratio desired between TV_HACTIVE and GCC_HACTIVE. (See Figure 6 below.) Like vertical scaling, TV_HACTIVE is the desired number of pixels the image should occupy, not necessarily the number of active pixels for the selected TV standard. A significant benefit of this architecture is that HTOTAL can be any arbitrary number that satisfies graphics controller timing requirements and PLL programming requirements.

For downscaling, $HDSC = (TV_HACTIVE / GCC_HACTIVE) * 256$ and $HUSC = 0$

For upscaling, $HUSC = ((TV_HACTIVE / GCC_HACTIVE - 1) * 256)$ and $HDSC = 0$

Figure 6: HSC Equations

Notes:

GCC_HACTIVE:	The number of active pixels in a line of computer graphics.
GCC_HTOTAL:	The total number of pixels in a computer graphics line, including active and blanking.
TV_HACTIVE:	The number of pixels in a line of TV video that will contain scaled graphics data.
TV_HTOTAL:	The total number of pixels in a TV line. PAL uses 864 pixels. NTSC uses 858 pixels.

HUSC and HDSC are programmed in register 08h (HSC).

For example, consider a case where the input graphics width is 800 pixels and the desired number of pixels to show is 650. The image must be scaled down horizontally, so HDSC is 208 (D0h) and HSC = 00D0h. For a case where input VGA width is 640 and the desired TV pixel count is 720, the image must be scaled up. HUSC is 32 (20h) and HSC = 2000h.

4.3 Vertical and Horizontal Position

The position of the graphics image on the television screen is controlled in two ways. The FS453 determines where input video data appears in time using the vertical and horizontal sync signals from the GCC. This means that adjusting the sync timing in the GCC will change the position of the active video area on the television. The FS453 also contains registers that control the offset from the sync transition. These registers allow the active video position on the television to be adjusted independent of the GCC sync timing.

The IHO (00h) register specifies the number of graphics pixels to skip before starting active video on the television. To position the actual video area at the left edge of the theoretical active area in TV space, program the IHO to the distance from the rising edge of HSYNC to the end of the line (HTOTAL). A larger number will shift video to the left, and a smaller number will shift video to the right.

The IVO (02h) register specifies the number of graphics lines to skip before starting active video on the television, counting from the rising edge of VSYNC. Programming the register is similar to programming IHO, but in the vertical direction.

5. Pin Assignments

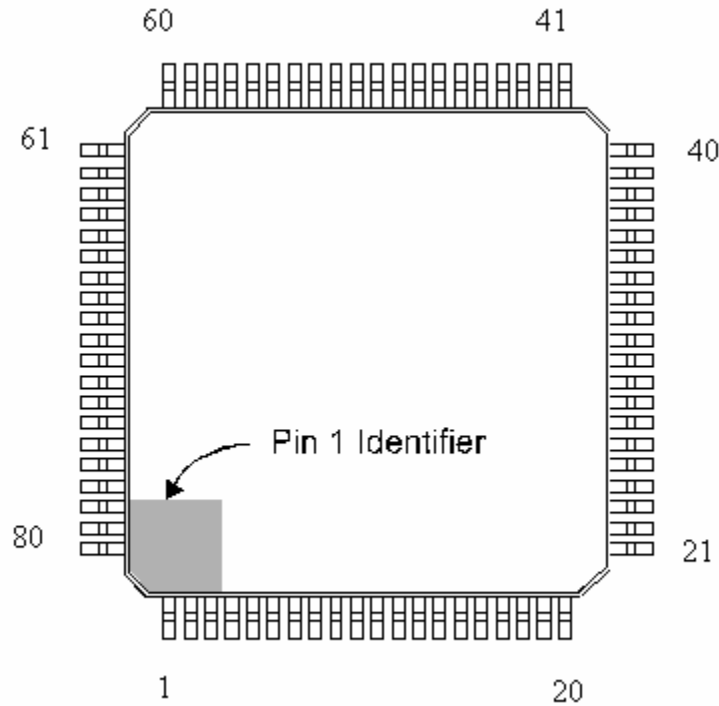

Figure 7: PQFP Pin Diagram

Pin	Name	Pin	Name	Pin	Name	Pin	Name
1.	VDD_DAD	21.	VSS_18	41.	VSS_18	61.	VDD_OSC
2.	GPIO3	22.	VSS_33	42.	VSS_33	62.	XTAL_OUT
3.	GPIO2	23.	P14/V656_2	43.	VSS_18	63.	XTAL_IN
4.	VSS_18	24.	P15/V656_3	44.	SDATA	64.	VSS_OSC
5.	P0	25.	P16/V656_4	45.	SCLK	65.	VSS_DA
6.	P1	26.	P17/V656_5	46.	VDD_33	66.	DAC_D
7.	P2	27.	P18/V656_6	47.	VDD_18	67.	VDD_DA
8.	P3	28.	P19/V656_7	48.	ALT_ADDR	68.	DAC_A
9.	P4	29.	P20	49.	PREF	69.	VDD_DA
10.	P5	30.	VDD_33	50.	GPIO0	70.	DAC_B
11.	P6	31.	VSS_33	51.	CLKIN_N	71.	VDD_DA
12.	P7	32.	P21/V656_H	52.	GPIO1	72.	DAC_C
13.	P8	33.	P22/V656_V	53.	RESET_L	73.	VDD_DA
14.	P9	34.	P23/V656_F	54.	CLKIN_P	74.	VSS_DA
15.	P10	35.	HSYNC	55.	VSS_O	75.	COMP
16.	P11	36.	VSYNC	56.	CLKOUT	76.	RSVD1
17.	P12/V656_0	37.	FIELD	57.	VDD_O	77.	VBIAS
18.	P13/V656_1	38.	BLANK	58.	VSS_PA	78.	FS_ADJ
19.	VDD_33	39.	RSVD0	59.	VDD_PA	79.	VSS_DA
20.	VDD_18	40.	VDD_18	60.	VDD_18	80.	VSS_DAD

Table 2: FS453 PQFP Pin Assignments

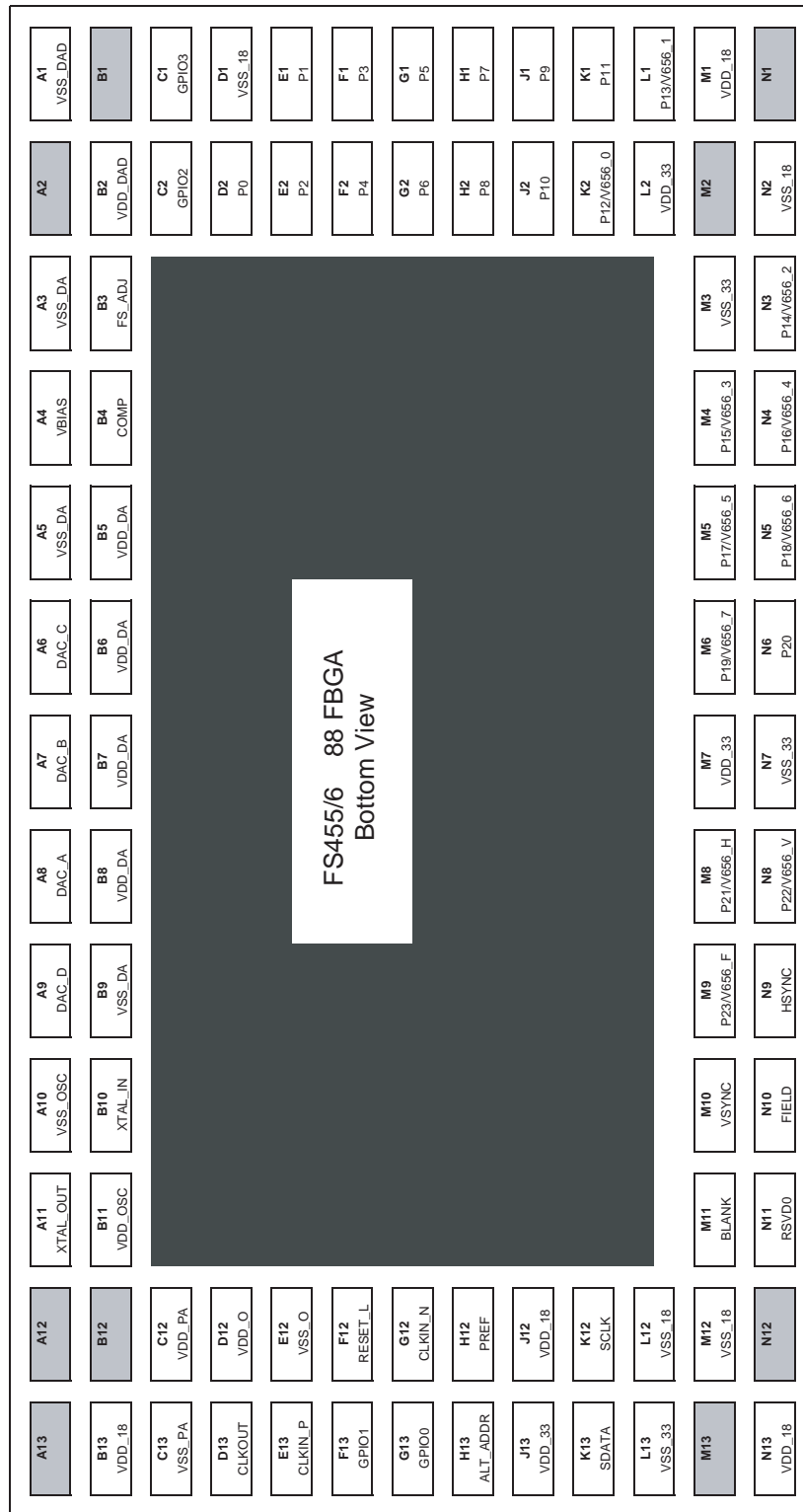

Figure 8 FBGA Pin Diagram

5.1 FS453 ↔ GCC Pin Mapping

Table 3 below maps the FS453 pins to the host GCC controller chip.

FBGA Pin #	PQFP Pin #	FS453 Pin Name	AMD Alchemy Pin Name	Freescaler Dragonball Pin Name	Intel DVO Pin Name	Intel XScale Pin Name	VIA Pin Name
D13	56	CLKOUT	GPIO	EXTAL16M	TVCLKIN		TVCLK
E13	54	CLKIN_P	LCD_PCLK	LSCLK	CLKOUT0	L_PCLK	TVCLKR
G12	51	CLKIN_N			CLKOUT1		
N9	35	HSYNC	LCD_LCLK	LP_HSYNC	TVHSYNC	L_LCLK	TVHS
M10	36	VSYNC	LCD_FCLK	FLM_VSYNC	TVVSYNC	L_FCLK	TVVS
M11	38	BLANK	LCD_BIAS		BLANK		BLANK
D2	5	P0	LCD_D16		LTVDATA0		TVDAT0
E1	6	P1	LCD_D17		LTVDATA1		TVDAT1
E2	7	P2	LCD_D18		LTVDATA2		TVDAT2
F1	8	P3	LCD_D19	LD12	LTVDATA3	LDD_11	TVDAT3
F2	9	P4	LCD_D20	LD13	LTVDATA4	LDD_12	TVDAT4
G1	10	P5	LCD_D21	LD14	LTVDATA5	LDD_13	TVDAT5
G2	11	P6	LCD_D22	LD15	LTVDATA6	LDD_14	TVDAT6
H1	12	P7	LCD_D23	LD16	LTVDATA7	LDD_15	TVDAT7
H2	13	P8	LCD_D8		LTVDATA8		TVDAT8
J1	14	P9	LCD_D9		LTVDATA9		TVDAT9
J2	15	P10	LCD_D10	LD6	LTVDATA10	LDD_5	TVDAT10
K1	16	P11	LCD_D11	LD7	LTVDATA11	LDD_6	TVDAT11
K2	17	P12/ V656_0 ^(a)	LCD_D12	LD8		LDD_7	
L1	18	P13/ V656_1	LCD_D13	LD9		LDD_8	
N3	23	P14/ V656_2	LCD_D14	LD10		LDD_9	
M4	24	P15/ V656_3	LCD_D15	LD11		LDD_10	
N4	25	P16/ V656_4	LCD_D0				
M5	26	P17/ V656_5	LCD_D1				
N5	27	P18/ V656_6	LCD_D2				
M6	28	P19/ V656_7	LCD_D3	LD0		LDD_0	
N6	29	P20	LCD_D4	LD1		LDD_1	
M8	32	P21/ V656_H	LCD_D5	LD2		LDD_2	
N8	33	P22/ V656_V	LCD_D6	LD3		LDD_3	
M9	34	P23/ V656_F	LCD_D7	LD4		LDD_4	
K12	45	SCLK	GPIO	SCL	LTVCL	SCL	SPCLK1
K13	44	SDATA	GPIO	SDA	LTVDA	SDA	SPD1

Table 3: FS453 to GCC Pin Mapping

^(a)Used for ITU-R BT.656 Video output

5.2 Pin Descriptions

Pin Name	FBGA Pin Number	PQFP Pin Number	Type/Value	Pin Function Description
Clocks				
CLKOUT	D13	56	GTL/LVCMOS output	Pixel Clock Output. Clock to Graphics Control Chip (GCC) clock input. Synthesized from XTAL_IN. 0.78125 to 150 MHz range. Supports 1.5 to 3.3 volt CMOS or GTL.
CLKIN_P	E13	54	Differential input	Pixel Clock Input Positive. Clock from GCC's buffered form of CLKOUT. Used to latch input pixel data.
CLKIN_N	G12	51	Differential input	Pixel Clock Input Negative. Clock from GCC's buffered form of CLKOUT. Used to latch input pixel data. For single-clocked use, tie CLKIN_N to PREF.
XTAL_IN	B10	63	LVTTTL input	Television reference Clock Input. 27 MHz reference clock input for the video encoder for use with either external oscillator or 27 MHz crystal.
XTAL_OUT	A11	62	LVTTTL output	Television Clock XTAL Output. Buffered version of XTAL_IN. For use with a 27 MHz crystal.
Global Controls				
RESET_L	F12	53	TTL input (internal pull down)	Reset. Active Low. Resets internal state machines and initializes default register values.
RSVD0	N11	39	TTL input (internal pull down)	Reserved. Manufacturing Test Pin. Tie to VSS.
GPIO3-GPIO0	C1,C2,F13,G13	2,3,52,50	TTL input/output	General Purpose Input/Output. GPIO port.
Digital RGB/YCrCb Input/Outputs				
P23-P0/V656	M9,N8,M8 N6,M6,N5 M5,N4,M4 N3,L1,K2 K1,J2,J1 H2,H1,G2 G1,F2,F1 E2,E1,D2	34,33,32, 29,28,27, 26,25,24, 23,18,17, 16,15,14, 13,12,11, 10,9,8, 7,6,5	GTL/TTL input/output	Digital GTL/TTL input port. Multiplexed digital video input. Connects to GCC's digital video out. In 12 bit input modes, P23-P12 are available for ITU-R BT.656 Video Output. P18-P12 contain the video data with embedded control codes while P21, P22, and P23 output HSync, VSync, and Field respectively.
PREF	H12	49	GTL/TTL REF	Digital GTL/TTL Port Reference input. Voltage threshold reference for GTL/TTL inputs. Set to the center of the input data logic high and low levels, but not to exceed Voltage Reference Range (see Electrical Characteristics on page 25).
HSYNC	N9	35	GTL/TTL I/O	Digital HSYNC VGA I/O. Connects to GCC HSync.
VSYNC	M10	36	GTL/TTL I/O	Digital VSYNC VGA I/O. Connects to GCC VSync.

Pin Name	FBGA Pin Number	PQFP Pin Number	Type/Value	Pin Function Description
BLANK	M11	38	GTL/TTL input	Digital BLANK VGA input. True outside of GCC active area. Connects to GCC blank pin (or to ground if a GCC blank pin is not available).
FIELD	N10	37	GTL/TTL output	Digital FIELD output. Delay and polarity programmable.

Pin Name	FBGA Pin Number	PQFP Pin Number	Type/Value	Pin Function Description
Video Outputs				
DAC_A	A8	68	analog video	Video output. As programmed by the DAC_CNTL (9Eh) register.
DAC_B	A7	70	analog video	Video output. As programmed by the DAC_CNTL (9Eh) register.
DAC_C	A6	72	analog video	Video output. As programmed by the DAC_CNTL (9Eh) register.
DAC_D	A9	66	analog video	Video output. As programmed by the DAC_CNTL (9Eh) register.
Voltage Reference				
RSVD1		76		Reserved. Not internally connected.
FS_ADJ	B3	78	549Ω or 1.1kΩ	Full Scale Adjust. A resistor connected between FS_ADJ and ground sets the current range of the D/A converters. Use 549Ω for a 37.5Ω load (common) or 1.1kΩ for a 75Ω load. Note that there is a 75 Ohm terminating resistor in consumer televisions.
COMP	B4	75	0.1 μF	Compensation. A 0.1μF capacitor must be connected between COMP and VDD_DA.
VBIAS	A4	77	100Ω/0.1μF	Voltage Bias Decoupling. An optional series 100Ω/0.1μF capacitor can be connected between VBIAS and VDD_DA to reduce noise at the D/A outputs. Otherwise, leave disconnected.
Serial Port				
ALT_ADDR	H13	48	TTL input (internal pull down)	Serial data address select. Selects the 7-bit serial bus address: ALT_ADDR = H: 0x6A ALT_ADDR = L: 0x4A
SDATA	K13	44	TTL I/O (open drain)	Serial data. Data line of the serial port. Connect to GCC serial data pin.
SCLK	K12	45	TTL Input	Serial clock. Clock line of the serial port. Connect to GCC serial clock pin.

Pin Name	FBGA Pin Number	PQFP Pin Number	Type/Value	Pin Function Description
Power and Ground				
VDD_PA	C12	59	+3.3 V	CLKOUT Phase-locked loop Power. Filtered 3.3 volt power for CLKOUT phase locked loop.
VDD_OSC	B11	61	+3.3 V	TV Crystal Oscillator Power. Filtered 3.3 volt power for XTAL oscillator.
VDD_33	J13,L2,M7	19,30,46	+3.3 V	Digital Power 3.3V. 3.3 volt power for I/O section of chip.
VDD_O	D12	57	+1.5 to 3.3 V	Digital Power Output. 1.5 to 3.3 volt power for clock output.
VDD_18	B13,J12,M1,N13	20,40,47,60	+1.8 V	Digital Power 1.8V. 1.8 volt power for digital section of chip.
VDD_DAD	B2	1	+3.3 V	D/A Converter Digital Power.
VDD_DA	B5,B6,B7,B8	67,69,71,73	+3.3 V	D/A Converter Power. Filtered 3.3 volt power for 10 bit video D/A converters.
VSS_PA	C13	58	0 V	CLKOUT phase-locked loop Ground.
VSS_OSC	A10	64	0 V	TV Crystal Oscillator Ground.
VSS_33	L13,M3,N7	22,31,42	0 V	Digital Ground. 3.3 volt power return.
VSS_O	E12	55	0 V	Digital Ground. 1.5 to 3.3 volt output power return.
VSS_18	D1,L12,M12,N2	4,21,41,43	0 V	Digital Ground. 1.8 volt power return.
VSS_DAD	A1	80	0 V	D/A Converter Digital Ground.
VSS_DA	A3,A5,B9	65,74,79	0 V	D/A Converter Analog Ground.

Table 4: FS453 Pin Descriptions

6. Control Register Function Map

Table 5 below lists the Control Register functions and register numbers. For more information about the Control Registers, please consult the **FS453/4 and FS455/6 Software / Firmware Reference**.

6.1 Register Reference Table

The General Function labels of the FS453 registers are intended to help design engineers determine which registers will affect specific functions of the FS453.

SDTV Input: FS453 input settings for SDTV applications
SDTV Output: FS453 SDTV output settings
HDTV Output: FS453 HDTV output settings
Control: FS453 control parameters
Clock: FS453 clock settings
Color Matrix: FS453 input color conversion matrix settings
QPR: The Quick Program Register (for rapid programming of the entire FS453)

General Function	Name	Offset	Default Value
SDTV Input	IHO	00h	0000h
SDTV Input	IVO	02h	0000h
SDTV Input	IHW	04h	02D0h
SDTV Input	VSC	06h	0000h
SDTV Input	HSC	08h	0000h
Control	BYPASS	0Ah	0000h
Control	CR	0Ch	0003h
Control	MISC	0Eh	8000h
Clock	NCON	10h	00020000h
Clock	NCOD	14h	00020000h
Clock	PLL M and Pump Control	18h	0409h
Clock	PLL N	1Ah	00AEh
Clock	PLL Post-Divider	1Ch	0505h
SDTV Input	SHP	24h	0000h
SDTV Input	FLK	26h	0000h
Control	GPIO	28h	0000h
Control	ID	32h	FE05h
Control	Status Port	34h	0008h
Control	FIFO_SP	36h	0000h
SDTV Input	FIFO_LAT	38h	0512h
SDTV Output	CHR_FREQ	40h	1F7CF021h
SDTV Output	CHR_PHASE	44h	00h
SDTV Output	MISC_45	45h	00h
SDTV Output	MISC_46	46h	09h

General Function	Name	Offset	Default Value
SDTV Output	MISC_47	47h	00h
SDTV Output	HSYNC_WID	48h	7Eh
SDTV Output	BURST_WID	49h	44h
SDTV Output	BPORCH	4Ah	76h
SDTV Output	CB_BURST	4Bh	3Bh
SDTV Output	CR_BURST	4Ch	00h
SDTV Output	MISC_4D	4Dh	00h
SDTV Output	BLACK_LVL	4Eh	0246h
SDTV Output	BLANK_LVL	50h	003Ch
SDTV Output	NUM_LINES	57h	0183h
SDTV Output	WHITE_LVL	5Eh	00C8h
SDTV Output	CB_GAIN	60h	89h
SDTV Output	CR_GAIN	62h	89h
SDTV Output	TINT	65h	00h
SDTV Output	BR_WAY	69h	16h
SDTV Output	FR_PORCH	6Ch	20h
SDTV Output	NUM_PIXELS	71h	00B4h
SDTV Output	1ST_LINE	73h	15h
SDTV Output	MISC_74	74h	02h
SDTV Output	SYNC_LVL	75h	48h
SDTV Output	VBI_BL_LVL	7Ch	004Ah
SDTV Output	SOFT_RST	7Eh	00h
SDTV Output	ENC_VER	7Fh	20h
SDTV Output	WSS_CONFIG	80h	07h
SDTV Output	WSS_CLK	81h	0072h
SDTV Output	WSS_DATAF1	83h	000000h
SDTV Output	WSS_DATAF0	86h	000000h
SDTV Output	WSS_LNF1	89h	00h
SDTV Output	WSS_LNF0	8Ah	00h
SDTV Output	WSS_LVL	8Bh	03FFh
SDTV Output	MISC_8D	8Dh	00h
Control	VID_CNTL0	92h	0000h
HDTV Output	HD_FP_SYNC	94h	0000h
HDTV Output	HD_YOFF_BP	96h	0000h
HDTV Output	SYNC_DL	98h	0000h
Control	LD_DET	9Ch	0000h
Control	DAC_CNTL	9Eh	0000h
Control	PWR_MGNT	A0h	000Fh

General Function	Name	Offset	Default Value
Color Matrix	RED_MTX	A2h	0000h
Color Matrix	GRN_MTX	A4h	0000h
Color Matrix	BLU_MTX	A6h	0000h
Color Matrix	RED_SCL	A8h	0000h
Color Matrix	GRN_SCL	AAh	0000h
Color Matrix	BLU_SCL	ACh	0000h
SDTV Output	CLOSED CAPTION FIELD 1	AEh	0000h
SDTV Output	CLOSED CAPTION FIELD 2	B0h	0000h
SDTV Output	CLOSED CAPTION CONTROL	B2h	0000h
SDTV Output	CLOSED CAPTION BLANKING VALUE	B4h	0000h
SDTV Output	CLOSED CAPTION BLANKING SAMPLE	B6h	0000h
HDTV Output	HACT_ST	B8h	0000h
HDTV Output	HACT_WD	BAh	0000h
HDTV Output	VACT_ST	BCh	0000h
HDTV Output	VACT_HT	BEh	0000h
SDTV Output	PR AND PB RELATIVE SCALING	C0h	0000h
SDTV Output	LUMA BANDWIDTH	C2h	0000h
QPR	QUICK PROGRAM REGISTER	C4h	8000h

Table 5: Register Reference Table

7. Specifications

7.1 Absolute Maximum and Recommended Ratings

(Beyond which the device may be damaged)^(a)

Parameter	Min	Rec.	Max	Unit
Power Supply Voltages				
V _{DD-33} (Measured to VSS_33)	-0.3	3.0-3.6	3.8	V
V _{DD-18} (Measured to VSS_18)	-0.3	1.62-1.95	2.4	V
V _{DD-DAD} (Measured to VSS_DAD)	-0.3	3.0-3.6	3.8	V
V _{DD-PA} (Measured to VSS_PA)	-0.3	3.0-3.6	3.8	V
V _{DD-DA} (Measured to VSS_DA)	-0.3	3.0-3.6	3.8	V
V _{DD-O} (Measured to VSS_O)	-0.3	3.0-3.6	3.8	V
V _{DD-OSC} (Measured to VSS_OSC)	-0.3	3.0-3.6	3.8	V
V _{SS-DA} , V _{SS-DAD} , V _{SS-PA} , V _{SS-33} , V _{SS-18} , V _{SS-O} , V _{SS-OSC} (delta)	-0.3		0.3	V
Digital Inputs				
3.3 V logic applied voltage (Measured to VSS_33) ^(b)	-0.3	0-V _{DD-33}	V _{DD-33} + 0.3	V
5V Tolerant (TTL) logic applied voltage	-0.3	3.0-5.5	6.5	V
Forced current ^(c,d)	-10.0		10.0	mA
Analog Outputs				
Applied Voltage (Measured to VSS_DA) ^(b)	-0.3	0-V _{DD-DA}	V _{DD-DA} + 0.3	V
Forced current ^(c,d)	-10.0		10.0	mA
Digital Outputs				
3.3 V logic applied voltage (Measured to VSS_33) ^(b)	-0.3	0-V _{DD-33}	V _{DD-33} + 0.3	V
5V Tolerant (TTL) logic applied voltage	-0.3	3.0-3.6	3.8	V
Forced current ^(c,d)	-6.0		6.0	mA
Short circuit duration (single output in HIGH state to ground)			1	second
Temperature				
Operating, Ambient	0		70	°C
Junction			125	°C
Case Temperature			95	°C
Lead Soldering (10 seconds)			300	°C
Vapor Phase Soldering (1 minute) ^(a)			220	°C
Storage ^(a)	-40		125	°C
Electrostatic				
Electrostatic Discharge ^(e)			±150	V

Notes:

- (a) Functional operation under any of these conditions is NOT implied. Performance and reliability are guaranteed only if operating within recommended ratings.
- (b) Applied voltage must be current limited to specified range.
- (c) Forcing voltage must be limited to specified range.
- (d) Current is specified as conventional current flowing into the device.
- (e) EIAJ test method.

Table 6: Absolute Maximum and Recommended Ratings

7.2 Electrical Characteristics

Parameter	Conditions	Min	Typ	Max	Unit	
Power Supply Currents						
I_{DD-18}	1.8 volt Digital current	Core clk =50MHz	75		mA	
I_{DD-DA}	3.3 volt DAC current	$R_L=37.5\Omega \times 4$	150	200	mA	
I_{DD-DA}	3.3 volt DAC current	$R_L=37.5\Omega \times 4$, DAC Low Power On	110		mA	
I_{DD-OSC}	3.3 volt Crystal Oscillator current	$C_L=72pF, 18pF$ Xtal	10		mA	
I_{DD-DPA}	3.3 volt Pixel PLL current		5	10	mA	
LVTTTL Inputs and Outputs						
C_I	Input Capacitance		5	10	pF	
C_O	Output Capacitance		5	10	pF	
I_{IH}	Input Current, HIGH	$V_{DD-33} = 3.3 \pm 0.3V$, $V_{IN} = \text{max.}$		± 10	μA	
I_{IL}	Input Current, LOW	$V_{DD-33} = 3.3 \pm 0.3V$, $V_{IN} = 0 V$		± 10	μA	
I_{ILP}	Input Current, LOW with pull-up	$V_{DD-33} = 3.3 \pm 0.3V$, $V_{IN} = 0 V$	-60	-10	μA	
V_{IH}	Input Voltage, Logic HIGH		2.0		V	
V_{IL}	Input Voltage, Logic LOW			0.8	V	
I_{OH}	Output Current, Logic HIGH			-4.0	mA	
I_{OL}	Output Current, Logic LOW			4.0	mA	
V_{OH}	Output Voltage, HIGH	$I_{OH} = -4mA$	2.4		V	
V_{OL}	Output Voltage, LOW	$I_{OL} = 4mA$		0.4	V	
Scalable GTL Inputs and Outputs						
C_I	I/O Capacitance		4	8	pF	
I_{IH}	Input Current, HIGH	$V_{DD-33} = 3.3 \pm 0.3V$, $V_{IN} = \text{max.}$		± 10	μA	
I_{IL}	Input Current, LOW	$V_{DD-33} = 3.3 \pm 0.3V$, $V_{IN} = 0 V$		± 10	μA	
V_{IH}	Input Voltage, Logic HIGH		$V_{REF} + .1$		V	
V_{IL}	Input Voltage, Logic LOW			$V_{REF} -.1$	V	
V_{PREF}	Voltage Reference Range		0.55	0.75	1.0	V
I_{OH}	Output Current, Logic HIGH			-10	μA	
I_{OL}	Output Current, Logic LOW			45.0	mA	
V_{OL}	Output Voltage, LOW	$I_{OL} = 45mA$	0.15	0.20	0.30	V
TTL Inputs and Outputs						
C_I	Input Capacitance		5	10	pF	
C_O	Output Capacitance		5	10	pF	
I_{IH}	Input Current, HIGH	$V_{DD-33} = 3.3 \pm 0.3V$, $V_{IN} = \text{max.}$		± 10	μA	
I_{IL}	Input Current, LOW	$V_{DD-33} = 3.3 \pm 0.3V$, $V_{IN} = 0 V$		± 10	μA	
I_{ILP}	Input Current, LOW with pull-up	$V_{DD-33} = 3.3 \pm 0.3V$, $V_{IN} = 0 V$	-60	-10	μA	
V_{IH}	Input Voltage, Logic HIGH		2.0		V	
V_{IL}	Input Voltage, Logic LOW			0.8	V	
I_{OH}	Output Current, Logic HIGH			-6.0	mA	
I_{OL}	Output Current, Logic LOW			6.0	mA	
SDATA I_{OL}	SDATA Output Current, Logic LOW			4.0	mA	
V_{OH}	Output Voltage, HIGH	$I_{OH} = -6mA$	2.4		V	
V_{OL}	Output Voltage, LOW	$I_{OL} = 6mA$		0.4	V	

Parameter	Conditions	Min	Typ	Max	Unit
Scalable LVTTTL (1.5 to 3.3V) Outputs					
I_{OH} (3.3V)	Output Current, Logic HIGH			-12.0	mA
I_{OL} (3.3V)	Output Current, Logic LOW			12.0	mA
V_{OH} (3.3V)	Output Voltage, HIGH	$I_{OH} = -12\text{mA}$	2.4		V
V_{OL} (3.3V)	Output Voltage, LOW	$I_{OL} = 12\text{mA}$		0.4	V
I_{OH} (2.5V)	Output Current, Logic HIGH			-8.0	mA
I_{OL} (2.5V)	Output Current, Logic LOW			8.0	mA
V_{OH} (2.5V)	Output Voltage, HIGH	$I_{OH} = -8\text{mA}$	2.0		V
V_{OL} (2.5V)	Output Voltage, LOW	$I_{OL} = 8\text{mA}$		0.4	V
I_{OH} (1.8V)	Output Current, Logic HIGH			-4.0	mA
I_{OL} (1.8V)	Output Current, Logic LOW			4.0	mA
V_{OH} (1.8V)	Output Voltage, HIGH	$I_{OH} = -4\text{mA}$	1.2		V
V_{OL} (1.8V)	Output Voltage, LOW	$I_{OL} = 4\text{mA}$		0.40	V
I_{OH} (1.5V)	Output Current, Logic HIGH			-4.0	mA
I_{OL} (1.5V)	Output Current, Logic LOW			4.0	mA
V_{OH} (1.5V)	Output Voltage, HIGH	$I_{OH} = -4\text{mA}$	1.0		V
V_{OL} (1.5V)	Output Voltage, LOW	$I_{OL} = 4\text{mA}$		0.40	V
Analog					
R_{IREF}	DAC Current Reference Resistor	$R_I = 37.5 \Omega$		549	Ω
I_{FS}	DAC Output Current	$R_{FS_ADJ} = 549 \Omega$		34.8	mA
P_{SSR}	DAC Supply Rejection Ratio	Freq. < 10 kHz	40	45	dB
K_{MATCH}	DAC to DAC Current Match	All DACs On	- 2.5	+ 2.5	%
V_{OC}	Video Output Compliance		0	1.4	V
C_{OUT}	Video Output Capacitance	$C_{OUT} = 0 \text{ mA}$, Freq. = 1 MHz		20	pF

Table 7: Electrical Characteristics

7.3 Switching Characteristics

Parameter	Conditions	Min	Typ ^(b)	Max	Unit
Clocks					
f _{CKIN}	TV Encoder Reference Clock Frequency		27.0		MHz
f _{XTOL}	TV Reference Clock Frequency Tolerance		30	50 ^(c)	ppm
t _{PWHT}	TV Reference Clock Pulse Width, HIGH		15.0		ns
t _{PWLT}	TV Reference Clock Pulse Width, LOW		15.0		ns
f _{CLKIN}	Pixel Clock Frequency	40/60 duty cycle	18.0	150.0	MHz
f _{CORE}	Scaler Core Frequency ^(d)			75.0	MHz
f _{GCKO}	GCC Clock Output Frequency ^(a,e,f)	GTL, 2.5V and 3.3V scalable	0.78125	150.0	MHz
f _{GCKO}	GCC Clock Output Frequency ^(e,f)	1.8V scalable	0.78125	120.0	MHz
f _{GCKO}	GCC Clock Output Frequency ^(e,f)	1.5V scalable	0.78125	85.0	MHz
t _{JIT-GCK}	GCC Clock Output Jitter (peak-to-peak)	over a cycle	-250	250	ps
DC _{GCK}	Duty Cycle	150 MHz	40	60	%
f _{PLLIN}	PLL Input Clock Frequency		100	1000	kHz
M	PLL Numerator (integer value)		250	3000	N/A
f _{PLLOUT}	PLL Output Clock Frequency		100	300	MHz
Reset	Assert f _{CKIN} cycles on RESET_L to reset		16		Clocks
Digital Pixel Input Port					
t _{PDH}	Pixel Clock 0 to Data/Control Hold Time	V _{REF} = 0.75V, 1.5V signaling.	0		ns
t _{PDH}	Pixel Clock 1 to Data/Control Hold Time	V _{REF} = 0.75V, 1.5V signaling.	0		ns
t _{PSU}	Pixel Clock 0 to Data/Control Setup Time	V _{REF} = 0.75V, 1.5V signaling.	1.2		ns
t _{PSU}	Pixel Clock 1 to Data/Control Setup Time	V _{REF} = 0.75V, 1.5V signaling.	1.2		ns
Serial Interface					
t _{DAL}	SCL Pulse Width, LOW		1.3		μs
t _{DAH}	SCL Pulse Width, HIGH		0.6		μs
t _{STAH}	SDA Start Hold Time		0.6		μs
t _{STASU}	SCL to SDA Setup Time (Stop)		0.6		μs
t _{STOSU}	SCL to SDA Setup Time (Start)		0.6		μs
t _{BUFF}	SDA Stop Hold Time Setup		1.3		μs
t _{DSU}	SDA to SCL Data Setup Time		100		ns
t _{DHO}	SDA to SCL Data Hold Time		0		ns

Table 8: Switching Characteristics

Notes:

- (a) GTL outputs are open drain and are specified with 25 ohm terminations from 1.1 to 1.5 volts and a 15 pF load.
- (b) Values shown in Typ column are typical for VDD33 = +3.3V, VDD18 = +1.8V, and TA = 25°C
- (c) TV subcarrier acceptance band is ± 300 Hz.
- (d) Scaler Core Frequency = VCO Frequency/PLL_IP
- (e) GCC Output Frequency = VCO Frequency/PLL_EP
- (f) Scalable (1.5 to 3.3V) LVTTTL outputs are specified with a 15 pF load.

8. Mechanical Dimensions

8.1 80-Lead PQFP Package

Symbol	Tols. \ Leads	Millimeters
A	MAX.	2.35
A1		0.25 MAX.
A2	+ .10 / - .05	2.00
D	+/- .25	17.20
D ₁	+/- .10	14.00
E	+/- .25	17.20
E ₁	+/- .10	14.00
e	BASIC	.65
L	+ .15 / - .10	.88
b	+/- .05	.30
α		0° - 7°
ddd		.12 NOM.
ccc	MAX.	.10

Notes:

1. All dimensions in millimeters.
2. Dimensions shown are nominal with tolerances as indicated.
3. Foot length "L" is measured at gage plane, 0.25 above seating plane.

Table 9: Package Dimensions

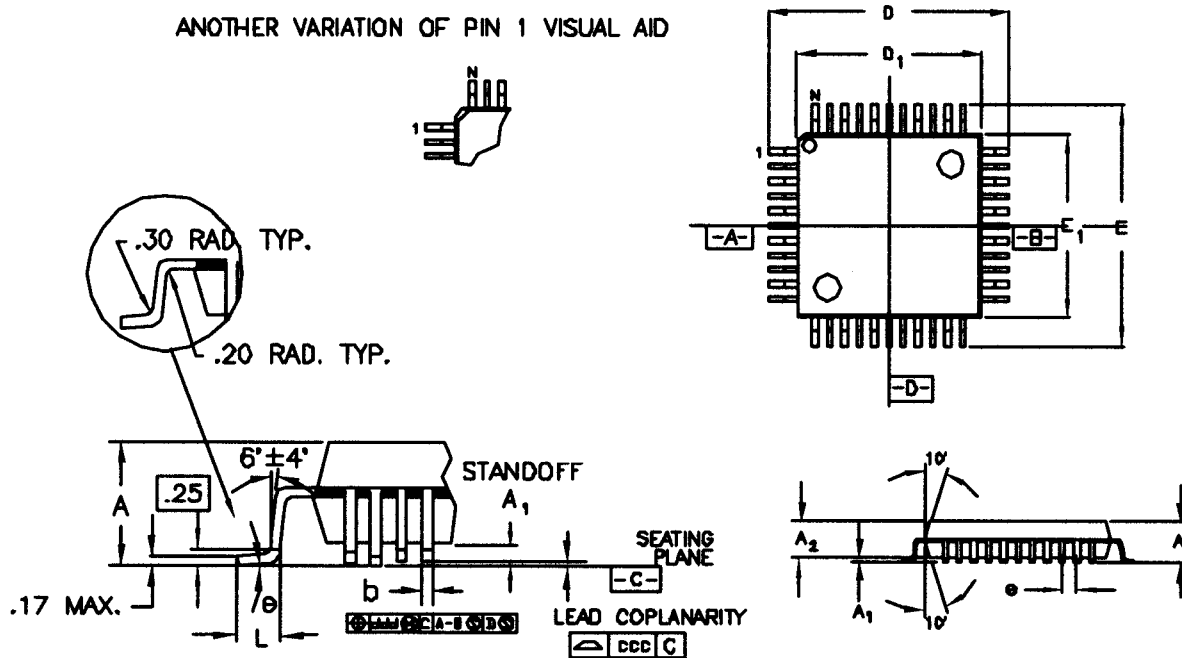

Figure 9: PQFP Package Outline & Dimensions

8.2 88-Lead FBGA Package

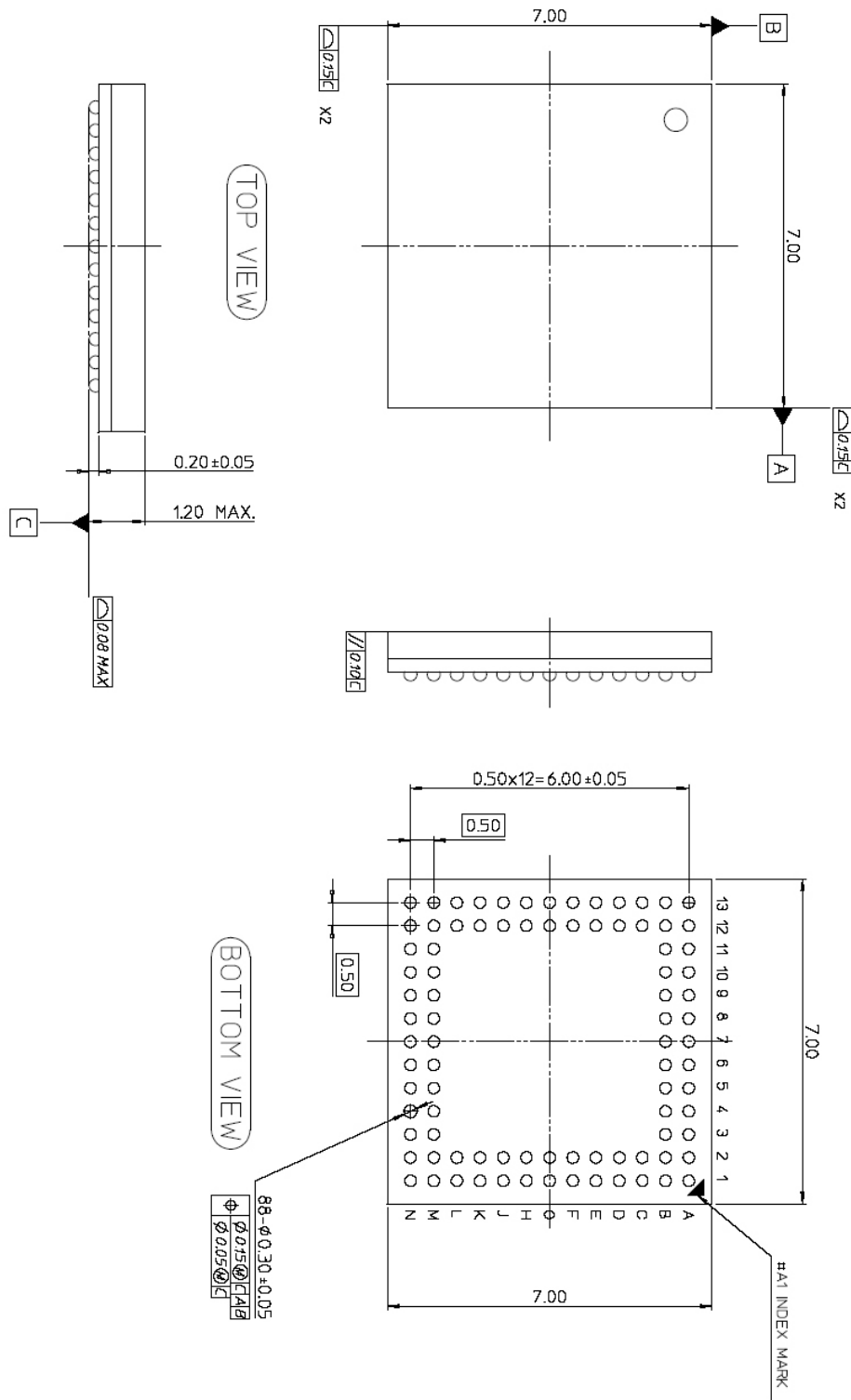

Figure 10 FBGA Package Outline & Dimensions

9. Component Placement

This section gives guidelines for the placement and layout of components associated with the FS453.

A printed circuit board (PCB) with a minimum of four layers is recommended for all designs utilizing the FS453. We recommend that layers 1 (top) and 4 (bottom) are used for signals, and that layers 2 and 3 are used for power and ground respectively. This provides the designer with ample access to all system traces and eases the process of manual design modification.

Place components associated with the FS453 as close as possible to their respective pins. Locate the FS453 near the power supply connector, the video input connector, and the video output connector.

Place the FS453 above a solid ground plane to shield EMI radiation. Additionally, do not route signal traces under the FS453.

9.1 Power/Ground

9.1.1 Power

To meet standard CMOS device voltage specifications, the FS453 can be powered by +3.3 Volts. In addition, the digital core of the chip can be powered by +1.8 Volts. However, since 5 Volt systems are still common, the FS453 can tolerate up to 5 Volt inputs.

If the switching power supply noise is greater than or equal to 200 mV, use a linear regulator to filter the analog power supply. It is best not to use unfiltered switching power supplies because they can produce substantial amounts of electrical noise. Excess electrical noise can induce visible artifacts on analog video signals, and should be avoided at all costs. To minimize electrical noise, always provide sufficient filtering and high frequency bypassing on the power supplies. This will insure better video quality and reduce EMI radiation.

Within the FS453, separate power is routed to each functional section of the die, including the phase locked loops, D/A converters, digital processors and digital drivers. Segregate the power pins into analog and digital power planes. Use separate voltage regulators for analog and digital power. It is important to isolate the analog plane from any electrical noise generated by the digital plane. We recommend isolating each power supply section from its respective voltage regulator with a series inductor/ferrite bead and a 4.7 μ F capacitor connected to ground. The ferrite bead filters high frequency switching noise, while the 4.7 μ F capacitor filters low-frequency power supply ripple and acts as a reservoir for heavy currents drawn by D/A converters.

Make sure you apply clean analog power to the V_{DD_PA} , V_{DD_OSC} , and V_{DD_DA} pins. For high-frequency power supply noise rejection, place a 0.1 μ F capacitor adjacent to each group of pins. To reduce the lead inductance, locate all capacitors as close as possible to the device and use the shortest possible leads (consistent with reliable operation). Chip capacitors are best for minimizing lead inductance. If necessary, you can substitute radial lead ceramic capacitors since they are better than axial lead capacitors for self-resonance. Chip capacitors are also recommended for power supply decoupling. Connect these capacitors as close to their respective power and ground pins as possible, using short and wide traces to minimize lead inductance. When two or more 0.1 μ F bypass capacitors are adjacent, consider exchanging one of them with a 100pF to 1000pF capacitor to reduce higher frequency noise from the power supply. Figure 11 on page 31 shows the recommended power filter networks.

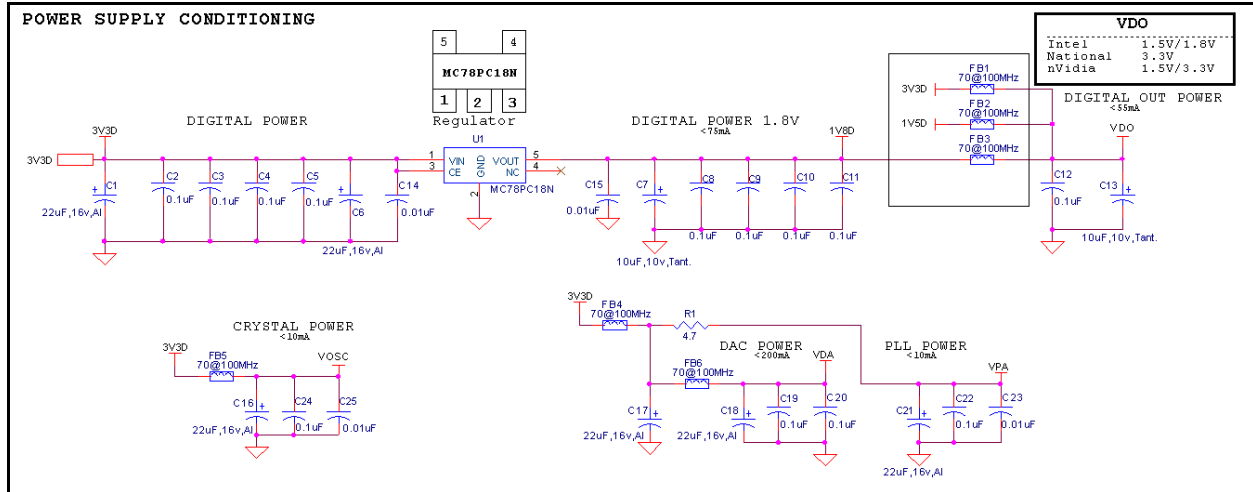

Figure 11: Recommended Power Filter Networks

9.1.2 Ground

Connect the analog and digital grounds of the FS453 to separate ground planes. This will insure that electrical noise from the digital ground does not pollute the analog ground. Connect these two planes with either a ferrite bead or a very thin trace. This will allow the two planes to maintain an equal voltage potential. Whenever possible, connect each of the FS453 ground pins directly to its respective decoupling capacitor ground lead, and then connect to the ground plane through a ground via. Use short and wide traces to minimize the lead inductance.

9.1.2.1 Special Consideration:

The FS453 is a high quality mixed process device that has excellent DAC Power Supply noise rejection (40db of rejection). Good PCB layout will result in an acceptably clean power supply.

In the noisiest environments, a dedicated voltage regulator can dramatically improve the quality of the power to the FS453. A point-of-use 5V to 3.3V 200mA regulator for the V_{DD_PA} and V_{DD_DA} lines is recommended in those situations. A single regulator can be used for both V_{DD_PA} and V_{DD_DA} lines, provided that those lines each have their own passive filter networks (see Figure 11 above). Placing a "no-stuff" zero ohm resistor between 3.3V and the regulated node will create the option of not populating the regulator. This allows the design engineer to save cost if testing shows that the regulator is not necessary.

9.2 DIGITAL SIGNALS

9.2.1 Digital Signal Routing

Isolate digital inputs to the FS453 from the analog outputs and other analog circuitry. The high-speed edge transition rates of the digital signals cause signal overshoot, undershoot, and ringing; this noise can directly couple onto any nearby signals. Do not overlay the analog power plane or analog output traces with digital signal traces. Using lower speed logic (3-5 ns edge rates) will benefit lower-speed applications by reducing data-related noise on the analog outputs. Reducing the digital edge transition rates (rise/fall time), minimizing ringing with damping resistors, and routing the digital traces perpendicular to any analog traces can prevent coupling the noise from the digital signals.

9.2.2 Video Inputs

The digital pixel data and the pixel clock of the FS453 may toggle at speeds up to 150 MHz (depending on input mode). It is critical that the traces used for these signals be kept as short as possible. They should be isolated from the analog outputs and analog circuitry. The signals carried on these traces are single ended high-speed signals and should be routed together as a bus. It is recommended that these traces be at least 8 mils wide.

9.3 ANALOG SIGNALS

9.3.1 Video Output Filters

9.3.1.1 Analog Signal Interconnect

Analog output traces are susceptible to electrical noise generated by digital signals. Digital traces must not be routed under or adjacent to the analog output traces. We recommend placing a third order reconstruction filter between the FS453 outputs and the output connectors. This filter network will smooth the stepped output of the FS453's DACs. The output filter network and the output connectors should be located as close as possible to the FS453. This will minimize the possibility of picking up noise from digital signals. It will also reduce the effects of transmission reflections due to impedance mismatches. To maximize high-frequency power supply noise rejection, the video output signals should overlay the ground plane. For maximum performance, the analog video output impedance, cable impedance, and load impedance should be matched. This will reduce signal transmission reflection.

The output DACs of the FS453 may be configured for many different video formats, since the pins have no fixed video assignments. The FS453 can assign any combination of Y, C, CVBS, and component (Y, Pr & Pb) signals to its four DACs. The video traces and the attached components should be laid out carefully in order to avoid signal coupling amongst each other. It is suggested that the video traces be separated with ground traces. Do not place the capacitors and inductors attached to those outputs too close to each other. Route the analog video signals with a minimum of 12 mils spacing between each other. There should be at least 20 mils between the analog video traces and any digital trace. Route the video traces in an area of the PCB that does not contain any digital traces. Sharp trace direction changes (e.g. 90deg) are, in effect, trace width irregularities that affect local transmission line impedances. These cause minute partial reflections in high-bandwidth signals. 150 MHz clocks with fast rise/fall times are probably more sensitive to this than 6MHz analog traces. Smooth curves are certainly preferred, and equal-distant traces help maintain time-alignment. The video traces should be kept on the top PCB layer with the FS453 to ensure that they are short and direct. Leave unused analog outputs open.

9.3.1.2 Suggested Output Filter Network

Figure 12 below shows the suggested output filter network for the FS453. Note that SDTV and HDTV use different values.

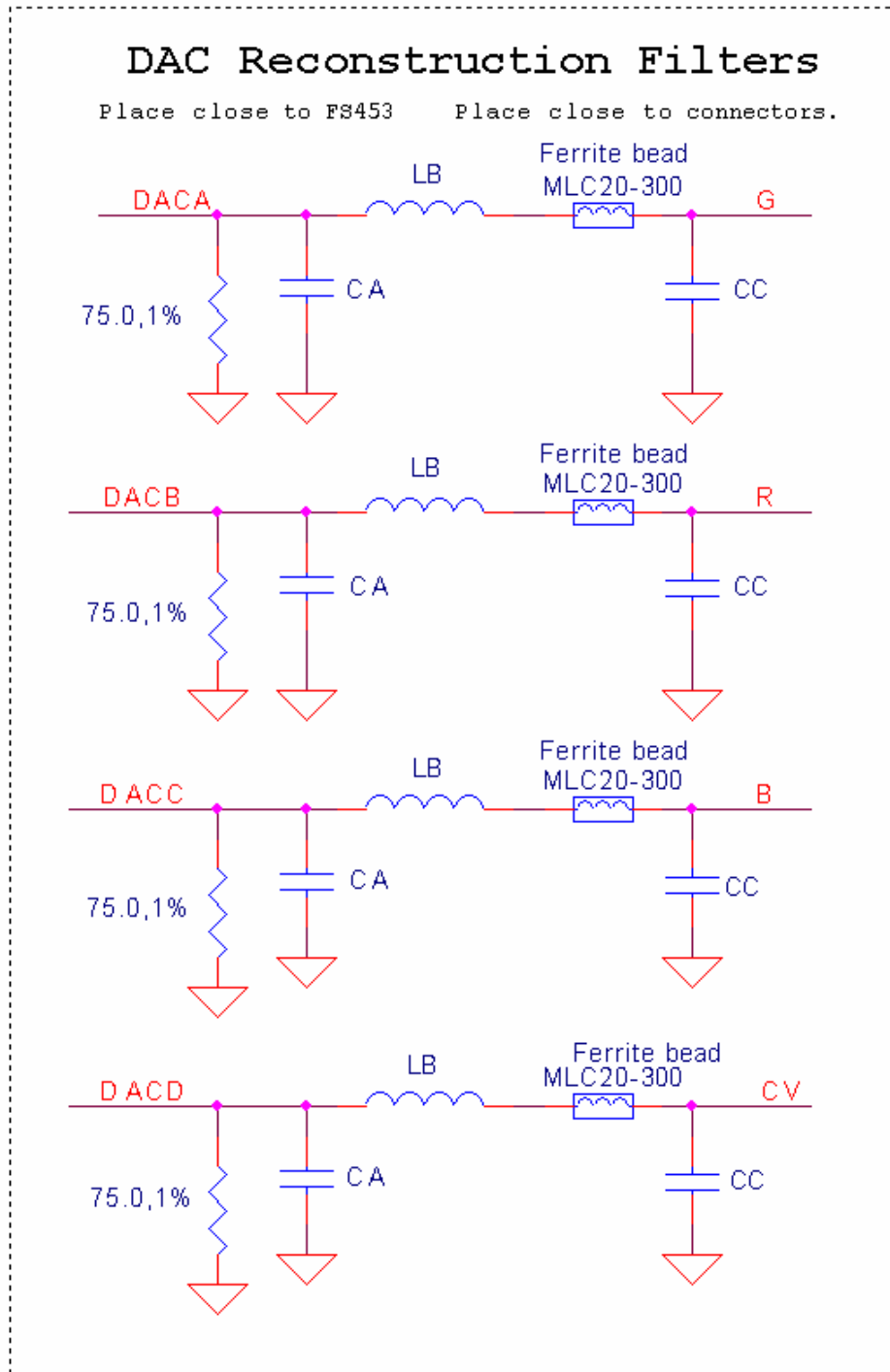

Figure 12: Recommended Output Filter

The recommended network shown in Figure 12 on page 33 will deliver robust video quality. It incorporates a source-terminating 75 Ohm resistor and a filter tuned for 37.5 Ohm impedance (assuming a matching 75 Ohm terminating resistor at the load). Table 10 below shows the correct component values to use for typical Standard and High Definition Television applications. For applications that utilize both HDTV and SDTV outputs, place HDTV filters on DACs A, B, & C and an SDTV filter on DAC D. Use DAC D for SDTV composite video, and the other DACs for all other video formats.

Output Filters	CA	LB	CC
SDTV	270p F	1.8uH	330p F
HDTV	47pF	330n H	68pF

Table 10: Output Filter Component Values

9.4 CLOCK/OSCILLATOR

9.4.1 Reference Crystal Oscillator

The quality of the image produced by the FS453 is directly related to the quality of the reference clock input to the chip. The FS453 can use either a dedicated external oscillator or the internal oscillator circuit with an inexpensive crystal as its reference clock. The reference clock must exhibit 50 parts per million (ppm) or better frequency tolerance (30 ppm preferred), and poses low jitter characteristics.

Any jitter or frequency deviation of the oscillating circuit will be transferred directly to the encoder's color subcarrier. Jitter within the valid clock cycle interval will result in hue noise on the color subcarrier on the order of 0.9-1.6 degrees per nanosecond. Random hue noise can result in degradation in the AM/PM noise ratio (typically around 40dB for consumer media such as videodiscs and VCRs). Periodic or coherent hue noise can result in differential phase error (which is limited to 10 degrees by FCC cable TV standards).

Any frequency deviation of the clock signal from nominal will challenge the subcarrier tracking capability of the destination receiver. This may range from a few ppm for broadcast equipment to a few hundred ppm for consumer equipment. Crystal based clock sources with a maximum total deviation of 30 ppm across the temperature range of 0 C to 70 C will produce the best results for consumer and industrial applications. Any clock interruption (even during vertical blanking interval) which results in misregistration of the clock input, or nonstandard pixel counts per line, can cause phase excursions outside the NTSC limit of +/- 40 degrees.

When using the internal oscillator circuit, you must meet the following conditions to ensure that the FS453 encoder operates properly. The crystal must be specified at 27.000 MHz +/- 50 ppm in parallel resonance (not series resonance). The external load capacitance needs to be equal to the specified capacitance value of the crystal. External load capacitors should have their ground connection very close to the FS453. A variable cap may be used to tune the external load capacitors. Since the crystal generates a timing reference for the FS453 encoder, it is important that electrical noise not couple into the circuit. Do not route traces with fast edge transition rates under or adjacent to these pins. Place the oscillating circuit as close as possible to the FS453. Traces connected from point to point should overlay the ground plane. If you use an external clock source, make sure it meets CMOS level specifications in addition to the frequency tolerance specifications.

9.4.2 FS453 Pixel Clock

In addition to the 27 MHz reference clock, the FS453 relies on a variable pixel clock to control the timing of the digital video signal from the graphics controller (Pseudo-master mode only). This pixel clock is generated by the FS453, sent to the graphics controller, and then returned to the FS453 along with the

graphics controller's digital video data. The timing of the variable pixel clock is critical; any disturbances to this signal will translate directly into noise on the video output.

The best method to stabilize the variable pixel clock signal is to source terminate the signal with a load that matches the impedance of the signal trace. The simplest transmission line termination is a series 33 Ohm SMD resistor placed as close to the source pin on the FS453 as possible. This works well as long as the signal only has one destination and does not change layers through vias.

Avoid passing the clock signal from layer to layer through vias. Each time a trace goes through a via, a reflection inducing impedance mismatch occurs at the via, and a completely different impedance will be present on the new layer. This makes proper termination of the clock signal nearly impossible. Geometry variations and sudden trace direction changes can also create impedance mismatches. Therefore, clock traces should maintain constant widths and have gradual/rounded direction changes.

For optimal results, match the impedance of the series termination resistor (nominally estimated at 33 Ohms) to the characteristic impedance of the trace. Use the URL link, <http://www.icd.com.au/board.html>, to locate an online calculator that can help define the characteristic impedance of a trace on a PCB. Maximum power transfer and minimum reflection occur when the load resistor equals the trace impedance.

Also be careful to prevent coupling between the pixel clock from the FS453 and the pixel clock (or clocks) that return from the graphics controller. All graphics controllers have internal Phase Locked Loops (which generate output clocks based on input clocks). The CLKIN_N & CLKIN_P outputs from a graphics controller are derived from the CLKOUT input from the FS453. Coupling from CLKOUT to CLKIN_N or CLKIN_P will cause positive feedback (and stability problems) for the graphics controller. Keep CLKOUT separated from CLKIN_N and CLKIN_P to prevent this from happening.

9.4.3 Pixel Clock Mode

Depending on the architecture and configuration of the graphics controller, the FS453 may use different clock mode settings. In all these modes HSync, VSync and the pixel data must meet the setup and hold time requirements (see Section 7.2 of the Hardware Reference, Switching Characteristics, Digital Input Port) with respect to pixel clock.

The FS453 operates as an integral piece of the computer graphics control circuit. The FS453 receives a digital video signal directly from the resident Graphics Controller Chip (GCC) and shares operating information with the GCC. There are two possible modes in which the FS453 can interface with a GCC: Pseudo-master Mode and Slave Mode.

9.4.3.1 Pseudo-master Mode

In Pseudo-master Mode shown below, the FS453 has complete control of the graphics system clock, but relinquishes the video sync signals to the GCC. The GCC provides the FS453 with a complete complement of digital video signals at the rate of the FS453 clock (CLKOUT).

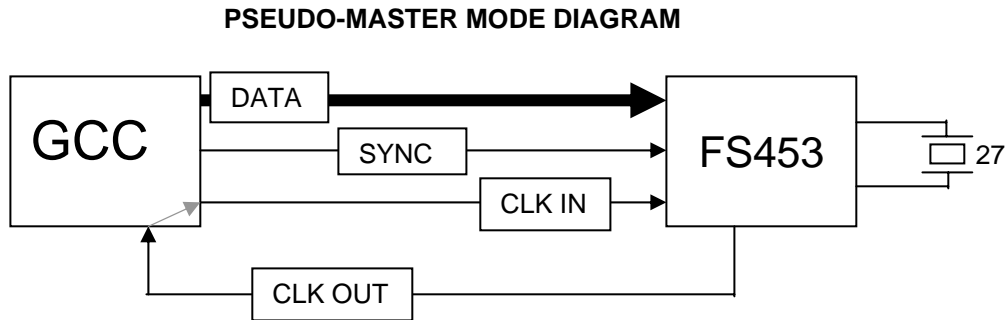

Figure 13: Pixel Clock Pseudo-master Mode

9.4.3.2 Slave Mode

In Slave Mode shown below, the FS453 is under the complete control of the GCC. The GCC provides the FS453 with all of the signals needed to produce an analog video signal. One must be careful when using the Slave Mode. Since the FS453 cannot control the GCC clock, the scalability of video images is limited. Additionally, if the GCC has a poor quality clock, the system will produce poor quality images.

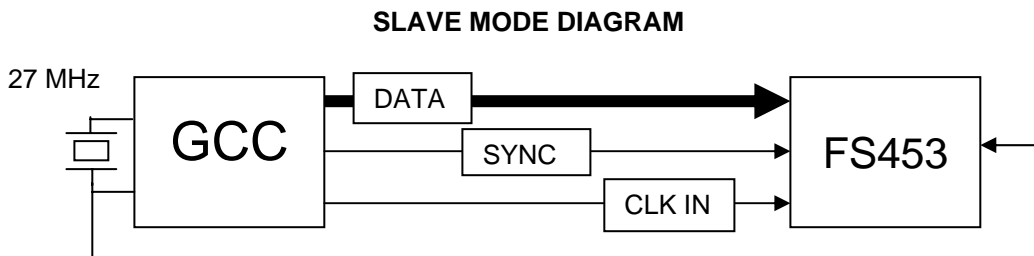

Figure 14: Pixel Clock Slave Mode

9.5 EMI Case Study

The following notes are from an engineer's experiences passing a new board through EMI testing.

- 1) You may need to analyze your board trace characteristic impedance, and adjust the optimal termination. If you can slowdown the edges without disturbing your timing, you can exorcise the (unnecessary) higher harmonics that can scoot across close trace clearances as if they were short circuits. It wouldn't hurt if you increase the trace to trace separation as much as possible.
- 2) You may add a 100pF shunt capacitor directly at the video connector pin, and put a ferrite bead between this cap and the output cap. This, in effect, creates a 5 pole low pass filter at EMI frequencies, but reduces to the original 3-pole in the video bandwidth (the ferrite impedance approaches zero). 100 pF was subtracted from the output cap. Therefore, instead of a Pi filter [270 pF, 1.8 uH, 330 pF], we had a double-Pi filter [270 pF, 1.8 uH, 220 pF, 40ohms @100 MHz, 100 pF]. Another possibility was to keep the 3-pole topology and simply add the ferrite in series with the inductor. Ferrite and shunt capacitor placement is critical. If they are not both right on the pin, HF will escape one way or another.
- 3) Use a near field EMI probe to identify hot spots before going to the lab. You can always use it again in the lab, if necessary.
- 4) Don't waste time with poor quality cables. Use a braid + foil cable from a reputable company.
- 5) A leaky PC can cause EMI emission failure. Almost any PC will leak if it has been banged around enough. Once you find a good PC, keep it under lock and key when not being used for EMI testing. A Gateway Performance 2000 PC™ (ATXSTF-FED) with upgraded VX920 monitor was found to be very quiet out of the box. Make sure your TV doesn't fail on its own as well.
- 6) Check that the card bracket is tightly coupled to the PC chassis frame and that all contacts are clean.
- 7) Another trick is to use a different layer stack-up, putting the signal traces on the inside, and using the ground and power planes as Faraday shields. However, unless the traces were placed at right angles on adjacent planes, this is not practical (Crosstalk becomes an issue).

9.6 Solder Re-flow Profiles

The following figures provide solder re-flow profiles for the PQFP and FBGA packages with lead and lead-free solder options.

IR Re-flow Profile

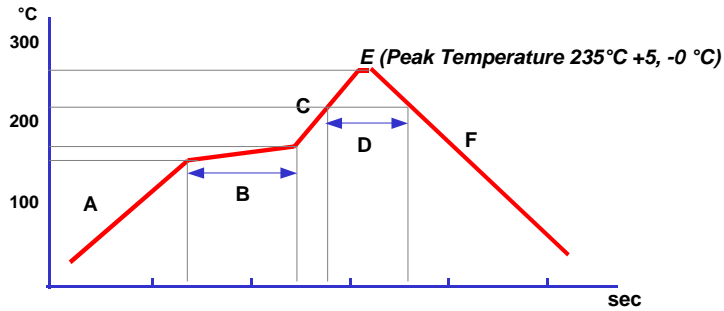

IR Re-flow Profile for Pre-conditioning						
Peak Temp.	Heat-up(A)	Pre-heat(B)	Heat-up(C)	Maintain(D)	Re-flow peak(E)	Cooling down(F)
Max. 240°C	3°C/sec Max.	140~160°C 60~120sec	3°C/sec Max.	20~60sec (Over 200°C)	Max. 235 +5, -0 °C 10sec +/-3sec	6°C/sec max.

Figure 15 PQFP Package (Lead Solder)

IR Re-flow Profile

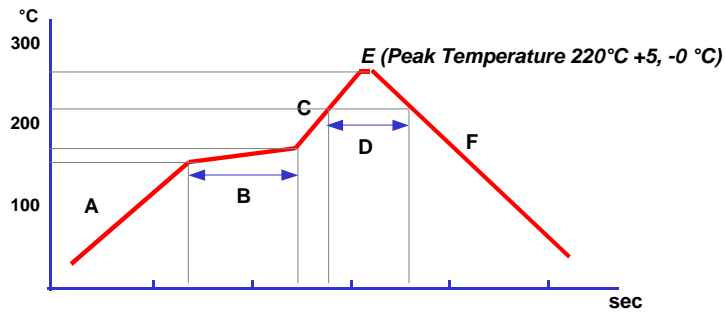

IR Re-flow Profile for Pre-conditioning						
Peak Temp.	Heat-up(A)	Pre-heat(B)	Heat-up(C)	Maintain(D)	Re-flow peak(E)	Cooling down(F)
Max. 225°C	3°C/sec Max.	140~160°C 60~120sec	3°C/sec Max.	60~150sec (Over 183°C)	Max. 220 +5, -0 °C 10sec ±3sec	6°C/sec max.

Figure 16 FBGA Package (Lead Solder)

IR Re-flow Profile & Moisture Absorption Condition

- ❖ IR sequence : Bake - Absorption - IR 3 times
- ❖ Moisture Absorption Condition : 30°C/60%RH, 192hrs

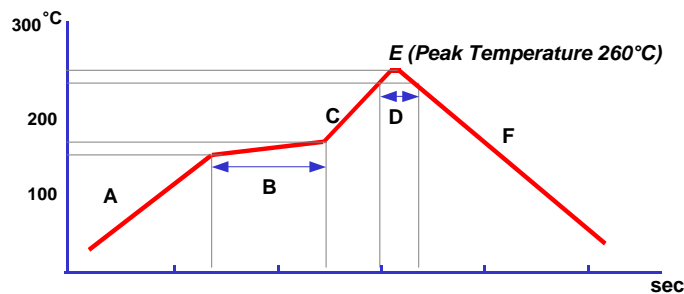

IR Re-flow Profile for Pre-conditioning						
Peak Temp.	Heat-up(A)	Pre-heat(B)	Heat-up(C)	Maintain(D)	Re-flow peak(E)	Cooling down(F)
Max. 260°C	3°C/sec Max.	160~190°C 90 ±30sec	3°C/sec Max.	255°C+5, -0°C 10 ±3sec	Max. 260°C	6°C/sec Max.

Figure 17 PQFP or FBGA Package (Lead-Free Solder)

10. Revision History

August 30, 2002: Release V1.1. Data Sheet reorganized into separate reference guides. The new Data Sheet package consists of a Product Brief, Hardware Reference, Software/Firmware Reference, and a Physical (Layout) Reference.

January 13, 2003: Release V2.0. Expanded Introduction and Architectural Overview. Added new sections: Technical Highlights and Scaling and Positioning Notes. Physical (Layout) Reference combined with Hardware Reference.

March 7, 2003: Release V2.1 Misc. minor edits. Replace and corrected part numbers, Noted incorporation of PCB Layout Guide into HR as chapter 9.

July 1, 2004: Release V3.0 Added FS455/6 packaging information. Incorporated video port and DAC application notes. Miscellaneous minor edits.

January 24, 2005: Release V3.1 Updated Lead-Free ordering information. Minor layout modifications to pin list.

11. Order Information

Order Number	Temperature Range	Screening	Package	Product
444-2133	0°C to 70°C	Commercial	80 Lead PQFP	FS453, Tape & Reel
444-2134	0°C to 70°C	Commercial	80 Lead PQFP	FS454, Tape & Reel
444-2137	0°C to 70°C	Commercial	88 Lead FBGA	FS455, Tape & Reel
444-2138	0°C to 70°C	Commercial	88 Lead FBGA	FS456, Tape & Reel

Package Markings:

FOCUS
Enhancements
<FS45x><LF><solder>
<YYWWWR>
<fab lot id>

where x = 3, 4, 5 or 6; LF = lead free; YY = year; WW = work week; R = die revision

solder = lead-free solder type (only present on devices with lead-free solder)

See <http://www.jedec.org/download/search/JESD97.pdf>

Note:

Any of the above SKUs can be ordered with lead-free solder. To place an order for a part with lead-free solder, append "LF" to the end of the SKU. For example 444-2137LF would be an FS455 with lead-free solder. All of these devices utilize the same die. They function identically except for Macrovision features (enabled in FS454 & FS456), package type, and solder type.

Please forward suggestions and corrections as soon as possible to the email address below. The information herein is accurate to the best of FOCUS' knowledge, but not all specifications have been characterized or tested at the time of the release of this document. Parameters will be updated as soon as possible and updates made available.

All parameters contained in this specification are guaranteed by: design, characterization, sample testing or 100% testing as appropriate. Focus Enhancements reserves the right to change products and specifications without notice. This information does not convey any license under patent rights of Focus Enhancements, Inc. or others.

Critical Applications Policy

Focus Enhancements components are not designed for use in Critical Applications. Critical Applications are products whose use may involve risks of death, personal injury, severe property damage or environmental damage or life support applications, devices, or systems, wherein a failure or malfunction of the component can reasonably be expected to result in death or personal injury. The user of Focus Enhancements components in Critical Applications assumes all risk of such use and indemnifies Focus Enhancements against all damages.

FOCUS Enhancements, Inc.

1370 Dell Avenue
Campbell, CA 95008
www.FOCUSinfo.com

Phone: (408) 866-8300
Fax: (408) 866-4859
Email: info@FOCUSinfo.com