



ISO212P

Low Cost, Two-Port Isolated, 1500Vrms ISOLATION AMPLIFIER

FEATURES

- 12-BIT ACCURACY
- 2.5mA (typ) QUIESCENT CURRENT
- LOW PROFILE (LESS THAN 0.5" HIGH)
- SMALL FOOTPRINT
- EXTERNAL POWER CAPABILITY ($\pm 8V$ at 5mA)
- "MASTER/SLAVES" SYNCHRONIZATION CAPABILITY
- INPUT OFFSET ADJUSTMENT
- LOW POWER (53mW)
- SINGLE 10V TO 15V SUPPLY OPERATION

APPLICATIONS

- INDUSTRIAL PROCESS CONTROL: Transducer Channel Isolator for Thermocouples, RTDs, Pressure Bridges, Flow Meters
- 4mA TO 20mA LOOP ISOLATION
- MOTOR AND SCR CONTROL
- GROUND LOOP ELIMINATION
- ANALYTICAL MEASUREMENTS
- POWER PLANT MONITORING
- DATA ACQUISITION/TEST EQUIPMENT ISOLATION
- MULTIPLEXED SYSTEMS WITH CHANNEL TO CHANNEL ISOLATION

DESCRIPTION

The ISO212P signal isolation amplifier is a member of a series of low-cost isolation products from Burr-Brown. The low-profile SIL plastic package allows PCB spacings of 0.5" to be achieved, and the small footprint results in efficient use of board space.

To provide isolation, the design uses high-efficiency, miniature toroidal transformers in both the signal and power paths. An uncommitted input amplifier and an isolated external bipolar supply ensure the majority of input interfacing or conditioning needs can be met. The ISO212P accepts an input voltage range of $\pm 5V$ for single 15V supply operation or $\pm 3.0V$ for single 10V supply operation.

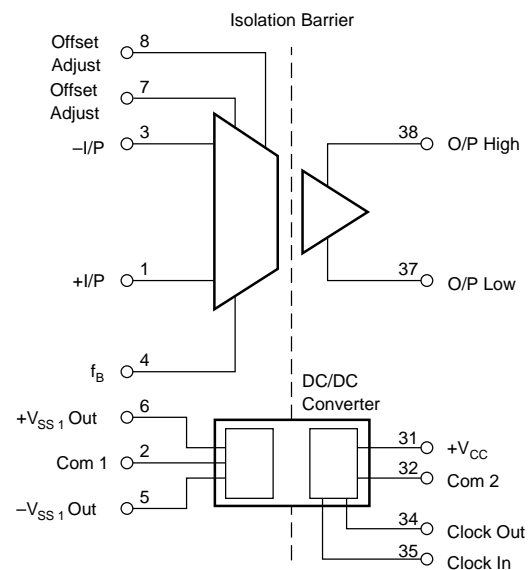

SPECIFICATIONS

ELECTRICAL

At $T_A = +25^\circ\text{C}$ and $V_{CC} = +15\text{V}$, unless otherwise noted.

PARAMETER	CONDITIONS	ISO212JP			ISO212KP, JP-15			UNITS
		MIN	TYP	MAX	MIN	TYP	MAX	
ISOLATION Voltage Rated Continuous AC, 50Hz DC 100% Test (AC, 50Hz) Isolation-Mode Rejection ⁽¹⁾ AC DC Barrier Resistance Barrier Capacitance Leakage Current ⁽⁸⁾	Partial Discharge 1s : <5pC $V_{ISO} = \text{Rated}$ Continuous 60Hz $V_{ISO} = 240\text{Vrms}$, 60Hz $V_{ISO} = 240\text{Vrms}$, 50Hz	750 1060 1200	115 160 10^{10} 12 1	2 1.6	1500 2120 2400	* ⁽⁹⁾ * * * *	* * *	Vrms VDC Vrms dB dB Ω pF μArms μArms
GAIN Initial Error Gain vs Temperature Nonlinearity ⁽³⁾ : KP JP-15	$V_O = -5\text{V to } +5\text{V}$		± 1 20 0.04	± 2 50 0.05		* * 0.015 0.04	* * 0.025 0.05	% FSR ⁽²⁾ ppm of FSR/ $^\circ\text{C}$ %FSR %FSR
INPUT OFFSET VOLTAGE Offset Voltage RTI: KP JP-15 vs Temperature vs Power Supply ⁽⁴⁾ Adjustment Range	$V_{CC} = 14\text{V to } 16\text{V}$		$30 \pm 30/\text{G}$ ± 1.5	$\pm 10 \pm 10/\text{G}$		* *	$\pm 7.5 \pm 7.5/\text{G}$ $\pm 10 \pm 10/\text{G}$	mV mV $\mu\text{V}/^\circ\text{C}$ mV/V mV
INPUT CURRENT Bias Offset				50 4			* *	nA nA
INPUT Voltage Range ⁽⁵⁾ Resistance	$G = 1$	± 5	10^{12}		*	*		V Ω
OUTPUT Output Impedance Voltage Range Ripple Voltage ⁽⁶⁾ Output Compliance	Out Hi to Out Lo Min Load = $1\text{M}\Omega$ $f = 0$ to 100kHz $f = 0$ to 5kHz Out Hi or Out Lo	± 5	3 8 0.4 7.5		*	* * *		k Ω V mVp-p mVrms V
FREQUENCY RESPONSE Small Signal Bandwidth Full Signal Bandwidth	I/P = 1Vp-p, -3dB $G = 1$ I/P = 10Vp-p, $G = 1$ $G = 10$ (-3dB)		1 200 1.8			* *		kHz Hz kHz
ISOLATED POWER OUTPUTS Voltage Outputs ($\pm V_{SS1}$) ⁽⁷⁾ vs Temperature vs Load Current Output ⁽⁷⁾ (Both Loaded) (One Loaded)	No Load	± 7.5	± 8 -8 90	5 8		* * *	* *	VDC mV/ $^\circ\text{C}$ mV/mA mA mA
POWER SUPPLIES Rated Voltage Voltage Range ⁽⁵⁾ Quiescent Current	Rated Performance No Load		15 11.4 to 16 2.5	3.5	*	* *	* *	V V mA
TEMPERATURE RANGE Specification Operating		0 -25		+70 +85	* *		* *	$^\circ\text{C}$ $^\circ\text{C}$

NOTES: (1) Isolation-mode rejection is the ratio of the change in output voltage to a change in isolation barrier voltage. It is a function of frequency. (2) FSR = Full Scale Range = 10V. (3) Nonlinearity is the peak deviation of the output voltage from the best-fit straight line. It is expressed as the ratio of deviation to FSR. (4) Power Supply Rejection is the change in V_{OS} /Supply Change. (5) At $V_{CC} = +10.0\text{V}$, input voltage range = $\pm 3.0\text{V}$ min. (6) Ripple is the residual component of the barrier carrier frequency generated internally. (7) Derated at $V_{CC} < +15\text{V}$. (8) Tested at 2400Vrms, 50Hz limit 16 μA . (9) Asterisk (*) same as ISO212JP.

PIN CONFIGURATION

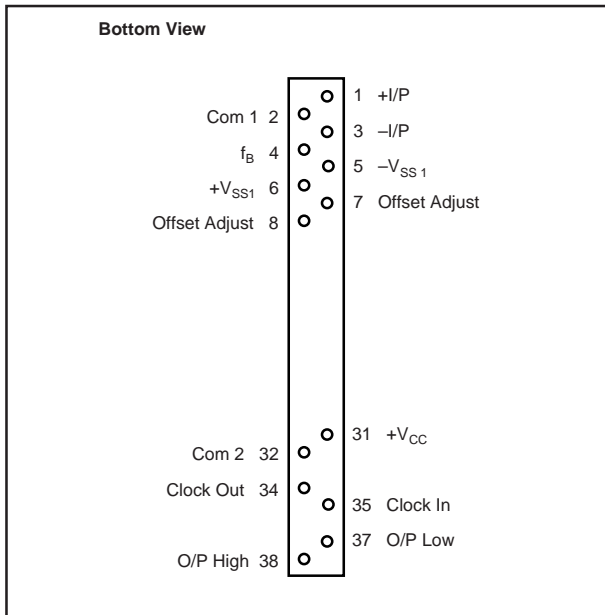

ABSOLUTE MAXIMUM RATINGS

Supply Voltage Without Damage	18V
Continuous Isolation Voltage Across Barrier: JP	750Vrms
KP, JP-15	1500Vrms
Storage Temperature Range	-25°C to 100°C
Lead Temperature (soldering, 10s)	+300°C
Amplifier Output Short-Circuit Duration	Continuous to Common
Output Voltage Hi or Lo to Com 2	$\pm V_{CC}/2$

PACKAGE/ORDERING INFORMATION

PRODUCT	PACKAGE	PACKAGE DRAWING NUMBER ⁽¹⁾	TEMPERATURE RANGE
ISO212JP	38-Pin Plastic SIP	326	-25°C to +85°C
ISO212JP-15	38-Pin Plastic SIP	326	-25°C to +85°C
ISO212KP	38-Pin Plastic SIP	326	-25°C to +85°C

NOTE: (1) For detailed drawing and dimension table, please see end of data sheet, or Appendix C of Burr-Brown IC Data Book.

ELECTROSTATIC DISCHARGE SENSITIVITY

This integrated circuit can be damaged by ESD. Burr-Brown recommends that all integrated circuits be handled with appropriate precautions. Failure to observe proper handling and installation procedures can cause damage.

ESD damage can range from subtle performance degradation to complete device failure. Precision integrated circuits may be more susceptible to damage because very small parametric changes could cause the device not to meet its published specifications.

TYPICAL PERFORMANCE CURVES

At $T_A = +25^\circ\text{C}$, $V_S = \pm 15\text{V}$, unless otherwise noted.

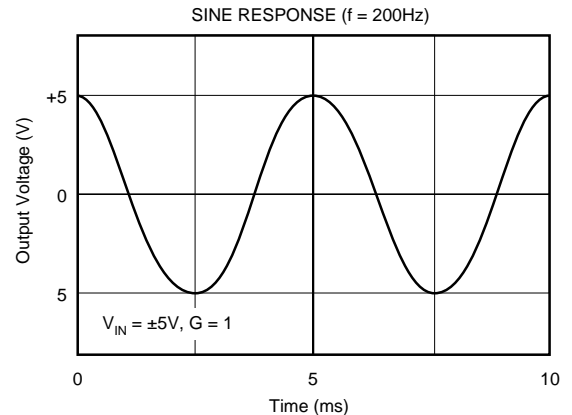
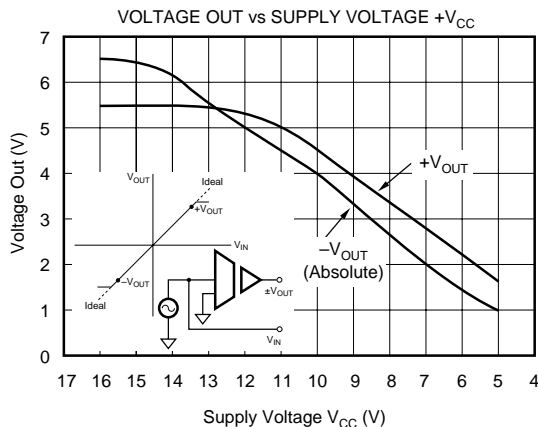

The information provided herein is believed to be reliable; however, BURR-BROWN assumes no responsibility for inaccuracies or omissions. BURR-BROWN assumes no responsibility for the use of this information, and all use of such information shall be entirely at the user's own risk. Prices and specifications are subject to change without notice. No patent rights or licenses to any of the circuits described herein are implied or granted to any third party. BURR-BROWN does not authorize or warrant any BURR-BROWN product for use in life support devices and/or systems.

TYPICAL PERFORMANCE CURVES (CONT)

At $T_A = +25^\circ\text{C}$ and $V_S = \pm 15\text{V}$, unless otherwise noted.

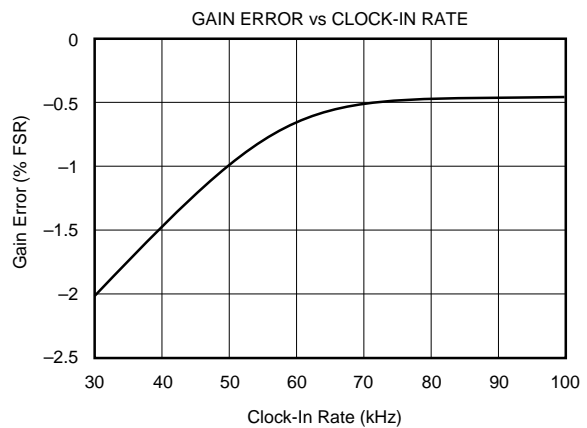
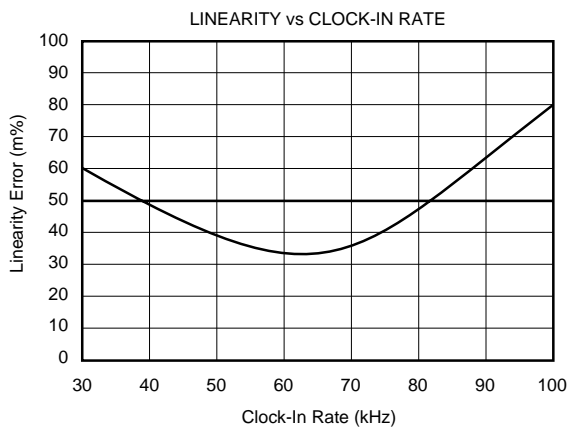
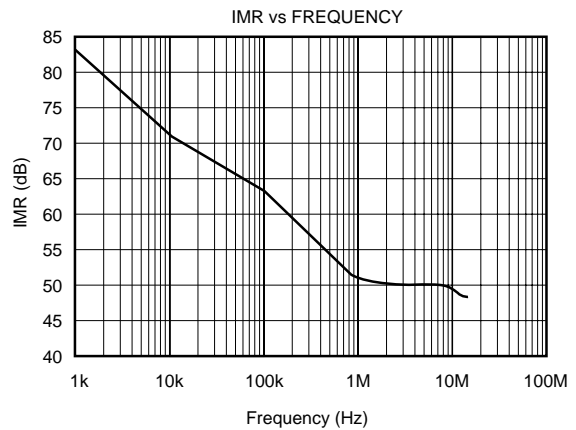
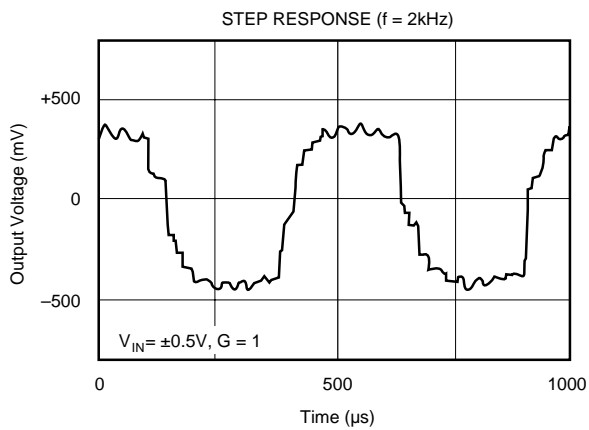
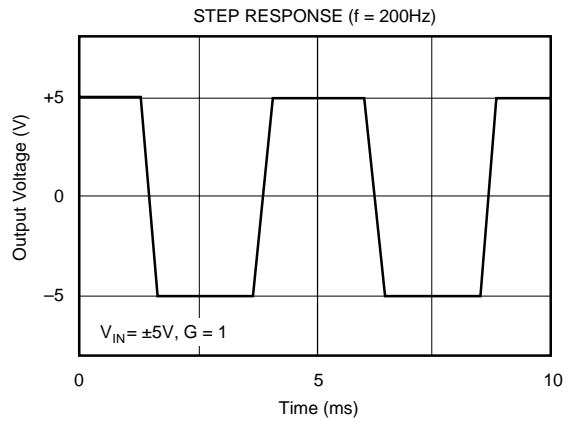
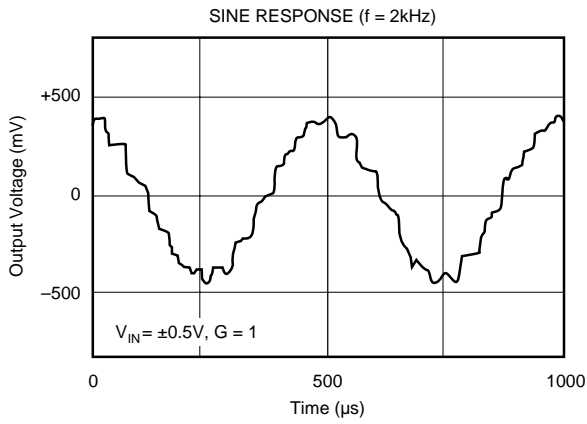

DISCUSSION OF SPECIFICATIONS

The ISO212P is intended for applications where isolation and input signal conditioning are required. Best signal-to-noise performance is obtained when the input amplifier gain setting is such that V_{OUT} has a full scale range of $\pm 5V$. The bandwidth is typically 1kHz, making the device ideal for use in conjunction with sensors that monitor slowly varying processes. To power external functions or networks, 5mA at $\pm 8V$ typical is available at the isolated port.

LINEARITY PERFORMANCE

The ISO212P offers linearity performance compatible with 12-bit resolution systems (0.025%). Note that the specification is based on a best-fit straight line.

OPTIONAL OFFSET VOLTAGE ADJUSTMENT

In many applications, the untrimmed input offset voltage will be adequate. For situations where it is necessary to trim the offset, a potentiometer can be used. See Figure 1 for details. It is important to keep the traces to the offset adjust pins as short as practical, because noise can be injected into the input op amp via this route.

INPUT PROTECTION

If the ISO212P is used in systems where a transducer or sensor does not derive its power from the isolated power available from the device, then some input protection must be present to prevent damage to the input op amp when the ISO212P is not powered. A resistor of $5k\Omega$ should be included to limit the output impedance of the signal source. Where the op amp is configured for an inverting gain, then R_{IN} of the gain setting network can be used. For non-

inverting configurations, a separate resistor is required. Neglecting this point may also lead to problems when powering on the ISO212P.

USING $\pm V_{SS1}$ TO POWER EXTERNAL CIRCUITRY

The DC/DC converter in the ISO212P runs at a switching frequency of 25kHz. Internal rectification and filtering is sufficient for most applications at low frequencies or with no external networks connected.

The ripple on $\pm V_{SS1}$ will typically be 100mVp-p at 25kHz. Loading the supplies will increase the ripple unless extra filtering is added externally; a capacitor of $1\mu F$ is normally sufficient for most applications, although in some cases $10\mu F$ may be required. Noise introduced onto $\pm V_{SS1}$ should be decoupled to prevent degraded performance.

THEORY OF OPERATION

The ISO212P has no galvanic connection between the input and output. The analog input signal referenced to the input common (Com 1) is multiplied by the gain of the input amplifier and accurately reproduced at the output. The output section uses a differential design so either the HI or LO pin may be referenced to the output common (Com 2). This allows simple input signal inversion while maintaining the high impedance input configuration. A simplified diagram of the ISO212P is shown in Figure 2. The design consists of a DC/DC converter, an uncommitted input operational amplifier, a modulator circuit and a demodulator circuit. Magnetic isolation is provided by separate transformers in the power and signal paths.

The DC/DC converter provides power and synchronization signals across the isolation barrier to operate the operational amplifier and modulator circuitry. It also has sufficient capacity to power external input signal conditioning net-

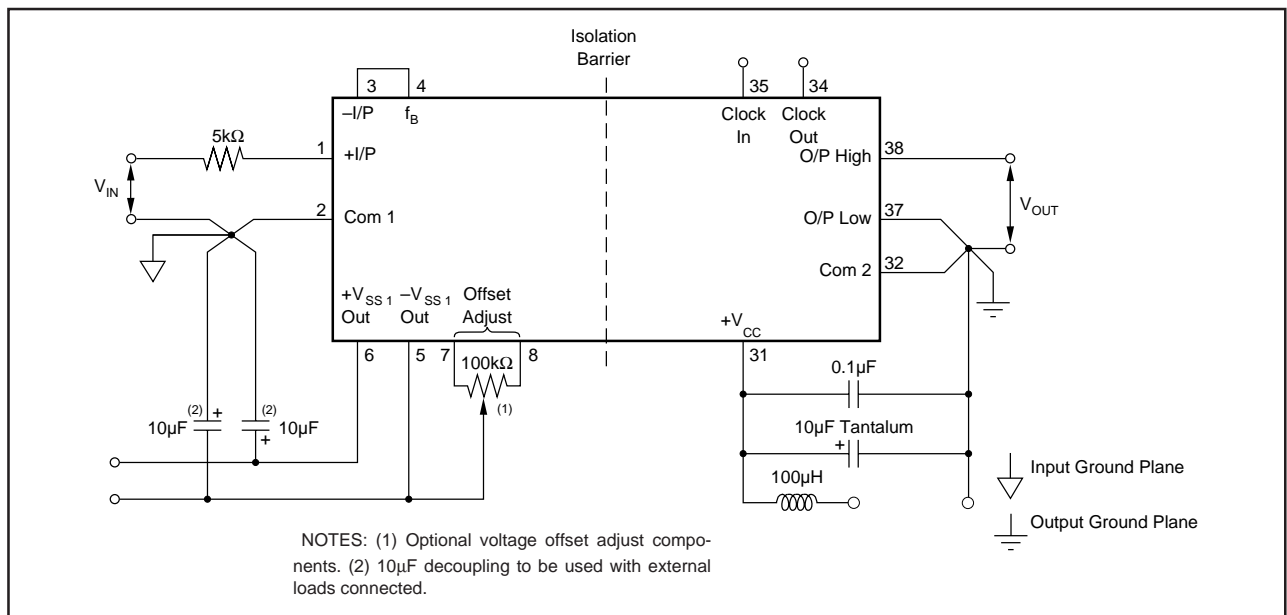

FIGURE 1. Power Supply and Signal Connections Shown for Non-Inverting, Unity Gain Configuration.

works. The uncommitted operational amplifier may be configured for signal buffering or amplification, depending on the application.

The modulator converts the input signal to an amplitude-modulated AC signal that is magnetically coupled to the demodulator by a miniature transformer providing the signal-path isolation. The demodulator recovers the input signal from the modulated signal using a synchronous technique to minimize noise and interference.

ABOUT THE BARRIER

For any isolation product, barrier integrity is of paramount importance in achieving high reliability. The ISO212P uses miniature toroidal transformers designed to give maximum isolation performance when encapsulated with a high-dielectric-strength material. The internal component layout is designed so that circuitry associated with each side of the barrier is positioned at opposite ends of the package. Areas where high electric fields can exist are positioned in the center of the package. The result is that the dielectric strength of the barrier typically exceeds 3kVrms.

ISOLATION VOLTAGE RATINGS

Because a long term test is impractical in a manufacturing situation, the generally accepted practice is to perform a production test at a high voltage for some shorter time. The relationship between actual test voltage and the continuously derated maximum specification is an important one. Historically, Burr-Brown has chosen a deliberately conservative one: $V_{TEST} = (2 \times AC_{rms} \text{ continuous rating}) + 1000V$ for ten seconds, followed by a test at rated ACrms voltage for one minute. This choice was appropriate for conditions where system transients were not well defined.

Recent improvements in high voltage stress testing have produced a more meaningful test for determining maximum permissible voltage ratings, and Burr-Brown has chosen to apply this new technology in the manufacture and testing of the ISO212P.

PARTIAL DISCHARGE

When an insulation defect such as a void occurs within an insulation system, the defect will display localized corona or ionization during exposure to high voltage stress. This ionization requires a higher applied voltage to start the discharge and a lower voltage to extinguish it once started. The higher start voltage is known as the inception voltage and the lower voltage is called the extinction voltage. Just as the total insulation system has an inception voltage, so do the individual voids. A voltage will build up across a void until its inception voltage is reached. At this point, the void will ionize, effectively shorting itself out. This action redistributes electrical charge within the dielectric and is known as partial discharge. If the applied voltage gradient across the device continues to rise, another partial discharge cycle begins. The importance of this phenomenon is that if the discharge does not occur, the insulation system retains its integrity. If the discharge begins and is allowed to continue, the action of the ions and electrons within the defect will eventually degrade any organic insulation system in which they occur. The measurement of partial discharge is both useful in rating the devices and in providing quality control of the manufacturing process. The inception voltage of these voids tends to be constant, so that the measurement of total charge being re-distributed within the dielectric is a very good indicator of the size of the voids and their likelihood of becoming an incipient failure.

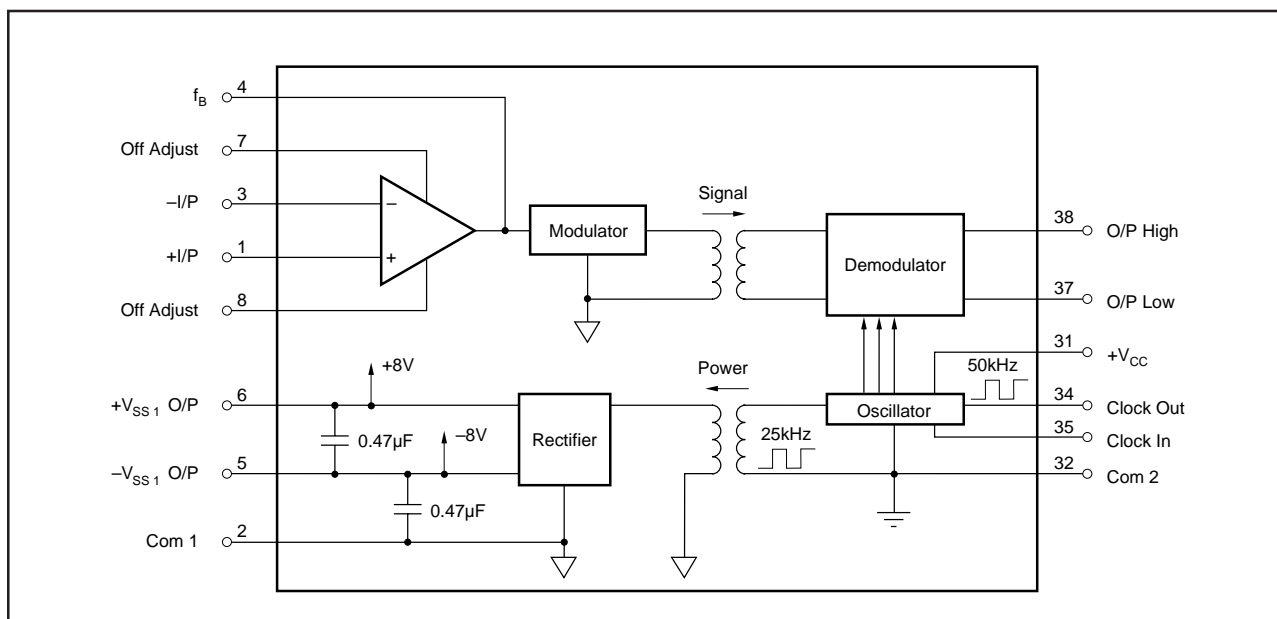

FIGURE 2. Simplified Diagram of Isolation Amplifier.

The bulk inception voltage, on the other hand, varies with the insulation system and the number of ionization defects. This directly establishes the absolute maximum voltage (transient) that can be applied across the test device before destructive partial discharge can begin.

Measuring the bulk extinction voltage provides a lower, more conservative, voltage from which to derive a safe continuous rating. In production, it's acceptable to measure at a level somewhat below the expected inception voltage and then de-rate by a factor related to expectations about the system transients. The isolation amplifier has been extensively evaluated under a combination of high temperatures and high voltage to confirm its performance in this respect. The ISO212P is free of partial discharges at rated voltages.

PARTIAL DISCHARGE TESTING IN PRODUCTION

Not only does this test method provide far more qualitative information about stress withstand levels than did previous stress tests, but it also provides quantitative measurements from which quality assurance and control measures can be based. Tests similar to this test have been used by some manufacturers such as those of high voltage power distribution equipment for some time, but they employed a simple measurement of RF noise to detect ionization. This method was not quantitative with regard to energy of the discharge and was not sensitive enough for small components such as isolation amplifiers. Now, however, manufacturers of HV test equipment have developed means to measure partial discharge, and VDE, the German standards group, has adopted use of this method for the testing of opto-couplers. To accommodate poorly defined transients, the part under test is exposed to a voltage that is 1.6 times the continuous rated voltage and must display < 5pC partial discharge level in a 100% production test.

INSTALLATION AND OPERATING INSTRUCTIONS

POWER SUPPLY AND SIGNAL CONNECTIONS

As with any mixed analog and digital signal component, correct decoupling and signal routing precautions must be used to optimize performance. Figure 1 shows the proper power supply and signal connections. V_{CC} should be bypassed to Com 2 with a 0.1 μ F ceramic capacitor as close to the device as possible. Short leads will minimize lead inductance. A ground plane will also reduce noise problems. If a low impedance ground plane is not used, signal common lines, and either O/P High or O/P Low pin should be tied directly to the ground at the supply and Com 2 returned via a separate trace to the supply ground.

To avoid gain and isolation mode (IMR) errors introduced by the external circuit, connect grounds as indicated in Figure 3. Layout practices associated with isolation amplifiers are very important. In particular, the capacitance associated with the barrier, and series resistance in the signal and reference leads, must be minimized. Any capacitance across

the barrier will increase AC leakage and, in conjunction with ground line resistance, may degrade high frequency IMR.

VOLTAGE GAIN MODIFICATIONS

The uncommitted operational amplifier at the input can be used to provide gain, signal inversion, active filtering or current to voltage conversion. The standard design approach for any op-amp stage can be used, provided that the full scale voltage appearing on f_B does not exceed $\pm 5V$.

If the input op-amp is overdriven, ripple at the output will result. To prevent this, the feedback resistor should have a minimum value of 10k Ω .

Also, it should be noted that the current required to drive the equivalent impedance of the feedback network is supplied by the internal DC/DC converter and must be taken into account when calculating the loading added to $\pm V_{SS1}$.

Since gain inversion can be incorporated in either the input or output stage of the ISO212P, it is possible to use the input amplifier in a non-inverting configuration and preserve the high impedance this configuration offers. Signal inversion at the output is easily accomplished by connecting O/P High to Com 2 instead of O/P Low.

ISOLATED POWER OUTPUT DRIVE CAPABILITY

On the input side of the ISO212P, there are two power supplies capable of delivering 5mA at $\pm 8V$ to power external circuitry. When using these supplies with external loads, it is recommended that additional decoupling in the form of 10 μ F tantalum bead capacitors be added to improve the voltage regulation. Loss of linearity will result if additional filtering is not used with an output load. Again, power dissipated in the feedback loop around the input op amp must be subtracted from the available power output at $\pm V_{SS1}$.

If the ISO212P is to be used in multiple applications, care should be taken in the design of the power distribution

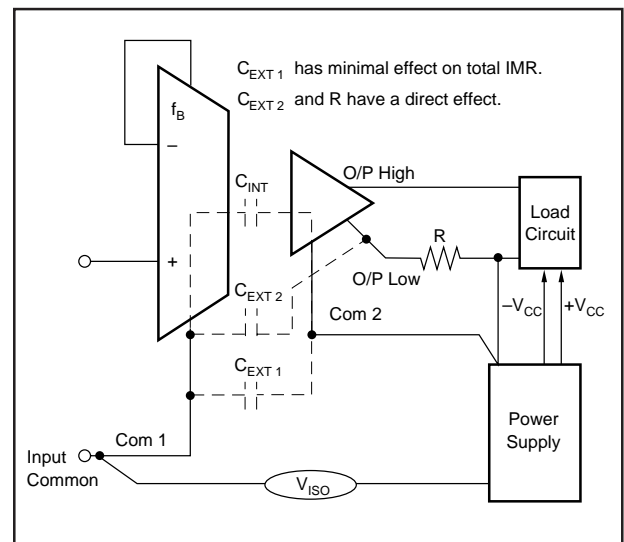

FIGURE 3. Technique for Connecting Com 1 and Com 2.

network, especially when all ISO212Ps are synchronized. It is best to use a well decoupled distribution point and to take power to individual ISO212Ps from this point in a star arrangement as shown in Figure 4.

NOISE

Output noise is generated by residual components of the 25kHz carrier that have not been removed from the signal. This noise may be reduced by adding an output low pass filter (see Figure 8). The filter time constants should be set below the carrier frequency. The output from the ISO212P is a switched capacitor and requires a high impedance load to prevent degradation of linearity. Loads of less than 1M Ω will cause an increase in noise at the carrier frequency and will appear as ripple in the output waveform. Since the output signal power is generated from the input side of the barrier, decoupling of the $\pm V_{SS1}$ outputs will improve the signal to noise ratio.

SYNCHRONIZATION OF THE INTERNAL OSCILLATOR

The ISO212P has an internal oscillator and associated timing components, which can be synchronized, incorporated into the design. This alleviates the requirement for an external high-power clock driver. The typical frequency of oscillation is 50kHz. The internal clock will start when power is applied to the ISO212P and Clk In is not connected.

Because the frequencies of several ISO212Ps can be marginally different, “beat” frequencies ranging from a few Hz to a few kHz can exist in multiple amplifier applications. The design of the ISO212P accommodates “internal synchronous” noise, but a synchronous beat frequency noise will not be strongly attenuated, especially at very low frequencies if it is introduced via the power, signal, or potential grounding paths. To overcome this problem in systems where several ISO212Ps are used, the design allows synchronization of each oscillator in a system to one frequency. Do this by forcing the timing node on the internal oscillator with an

external driver connected to Clk In. See Figure 5. The driver may be an external component with Series 4000 CMOS characteristics, or one of the ISO212Ps in the system can be used as the master clock for the system. See Figure 6 and 7 for connections in multiple ISO212P installations.

CHARGE ISOLATION

When more than one ISO212P is used in synchronous mode, the charge which is returned from the timing capacitor (220pF in Figure 5) on each transition of the clock becomes significant. Figure 7 illustrates a method of isolating the “Clk Out” clamp diodes (Figure 5) from this charge.

A 22k Ω resistor (recommended maximum to use) together with the 39k Ω internal oscillator timing resistor (Figure 5) forms a potential divider. The ratio of these resistors should be greater than 0.6 which ensures that the input voltage triggers the inverter connected to “Clk In”. If using a single resistor, then account must be taken of the paralleled timing resistors. This means that the 22k Ω resistor must be halved to drive two ISO212Ps, or divided by 8 if driving 8 ISO212Ps to insure that the ratio of greater than 0.6 is maintained. The series resistors shown in Figure 7 reduce the high frequency content of the power supply current.

APPLICATIONS

The ISO212P isolation amplifier, together with a few low cost components, can isolate and accurately convert a 4-to-20mA input to a $\pm 10V$ output with no external adjustment. Its low height (0.43" (11mm)) and small footprint (2.5" x 0.33" (57mm x 8mm)) make it the solution of choice in 0.5" board spacing systems and in all applications where board area savings are critical.

The ISO212P operates from a single +15V supply and offers low power consumption and 12-bit accuracy. On the input side, two isolated power supplies capable of supplying 5mA at $\pm 8V$ are available to power external circuitry.

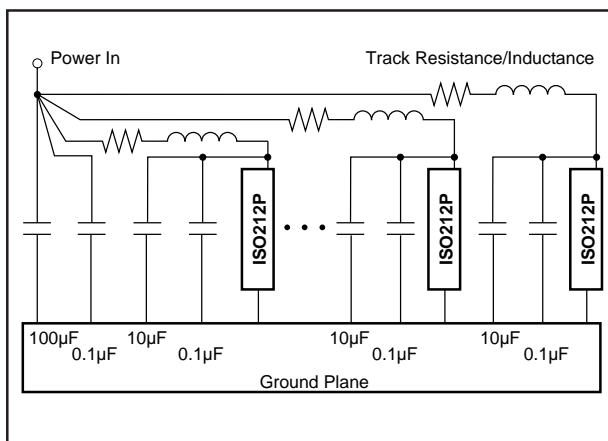

FIGURE 4. Recommended Decoupling and Power Distribution.

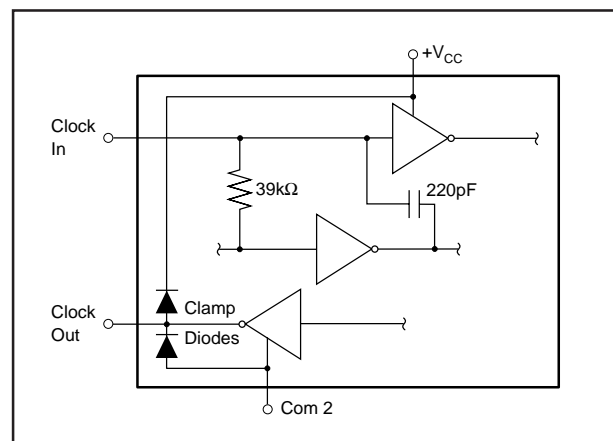

FIGURE 5. Equivalent Circuit, Clock Input/Output. Inverters are CMOS.

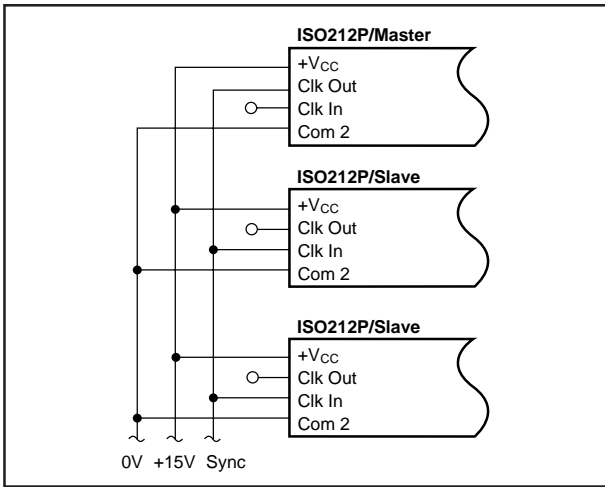

FIGURE 6. Oscillator Connections for Synchronous Operation in Multiple ISO212P Installations.

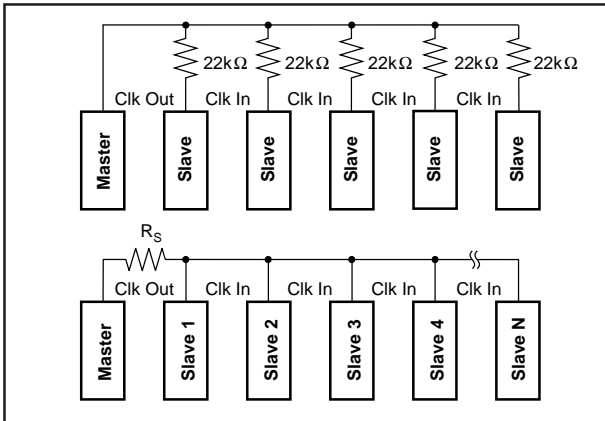

FIGURE 7. Isolating the Clk Out Node.

APPLICATIONS FLEXIBILITY

In Figure 8, the ISO212P's $+V_{SS1}$ isolated supply powers a REF200 to provide an accurate $100\mu\text{A}$ current source. This current is opposed by an equal but opposite current through the $75\text{k}\Omega$ feedback resistor to establish an offset of -7.5V at $I_{in} = 0\text{mA}$. With $I_{in} = 4\text{-to-}20\text{mA}$, the output is -5 to $+5\text{V}$. The ratio of the $75\text{k}\Omega$ and $3.12\text{k}\Omega$ resistors assures the correct gain.

The polarity of the output can be reversed by simply reversing the O/P HI and O/P LO pins. This could be used in the Figure 8 circuit to change the -5V to $+5\text{V}$ output to a $+5\text{V}$ to -5V output range.

The primary function of the output circuitry is to add gain to produce a $\pm 10\text{V}$ output and to reduce output impedance. The addition of a few resistors and capacitors provides a low pass filter with a cut-off frequency equal to the full signal bandwidth of the ISO212P, typically 200Hz . The filter response is flat to 1dB and rolls off from cut off at -12dB per octave.

The accuracy of the REF200 and external resistors eliminates the need for expensive trim pots and adjustments. The errors introduced by the external circuitry only add about 10% of the ISO212P's specified gain and offset voltage error.

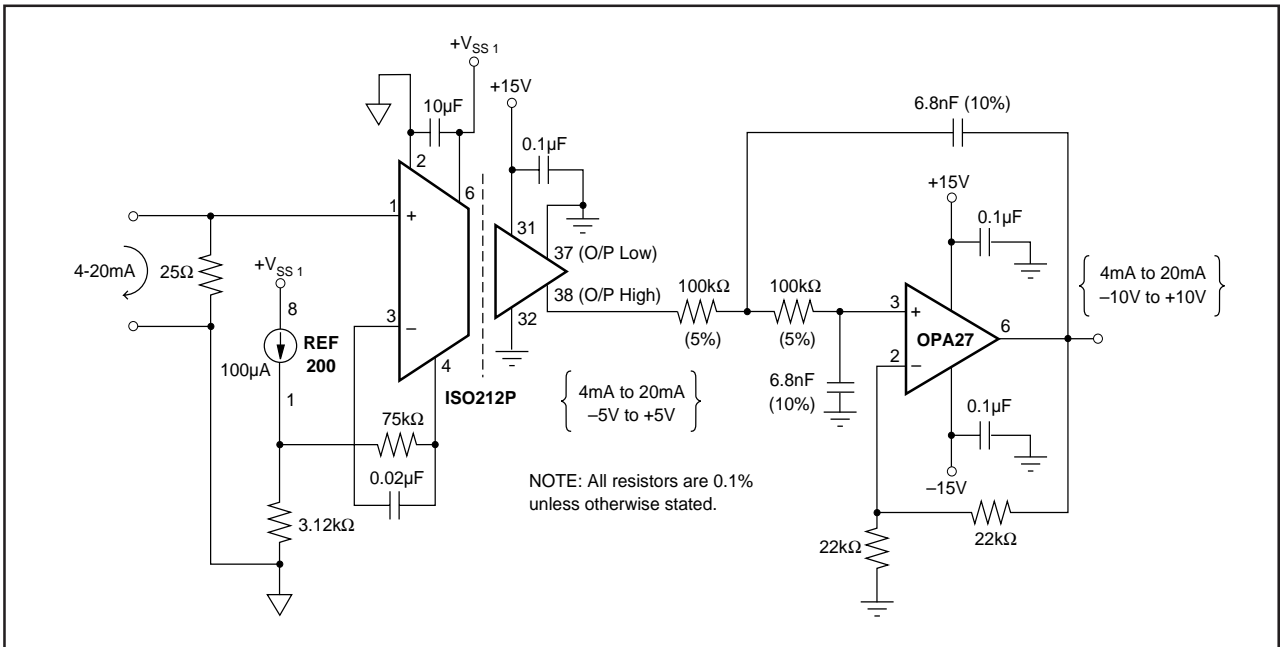

FIGURE 8. Isolated 4-20mA Current Receiver with Output Filter.

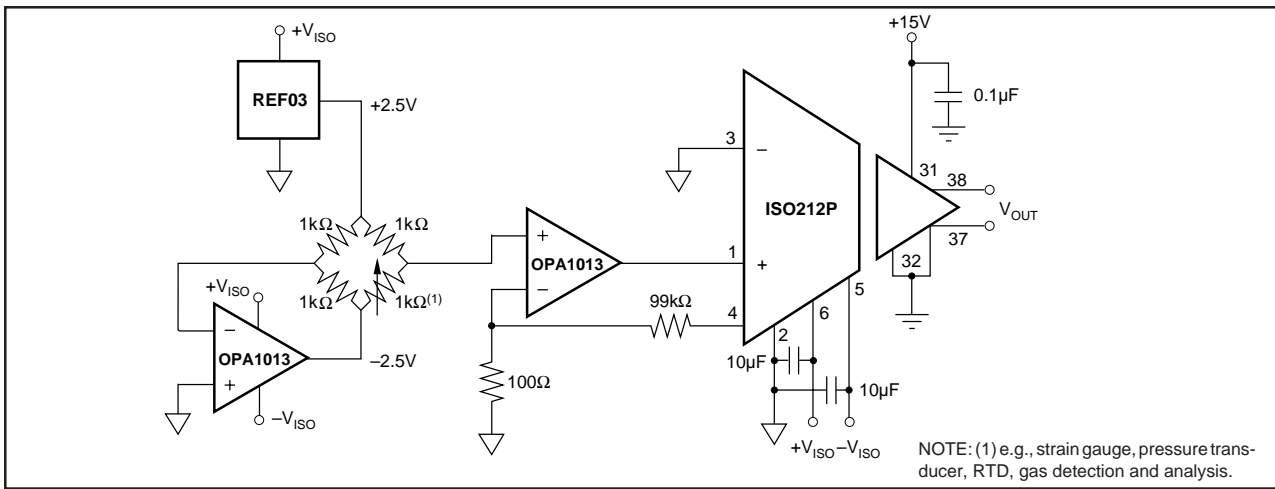

FIGURE 9. Instrument Bridge Isolation Amplifier.

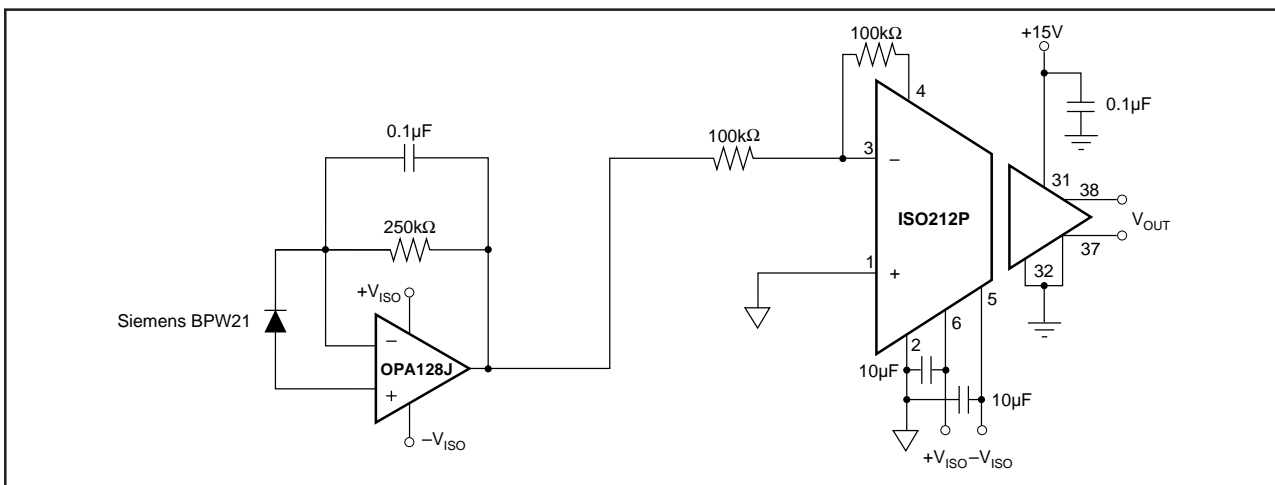

FIGURE 10. Photodiode Isolation Amplifier.

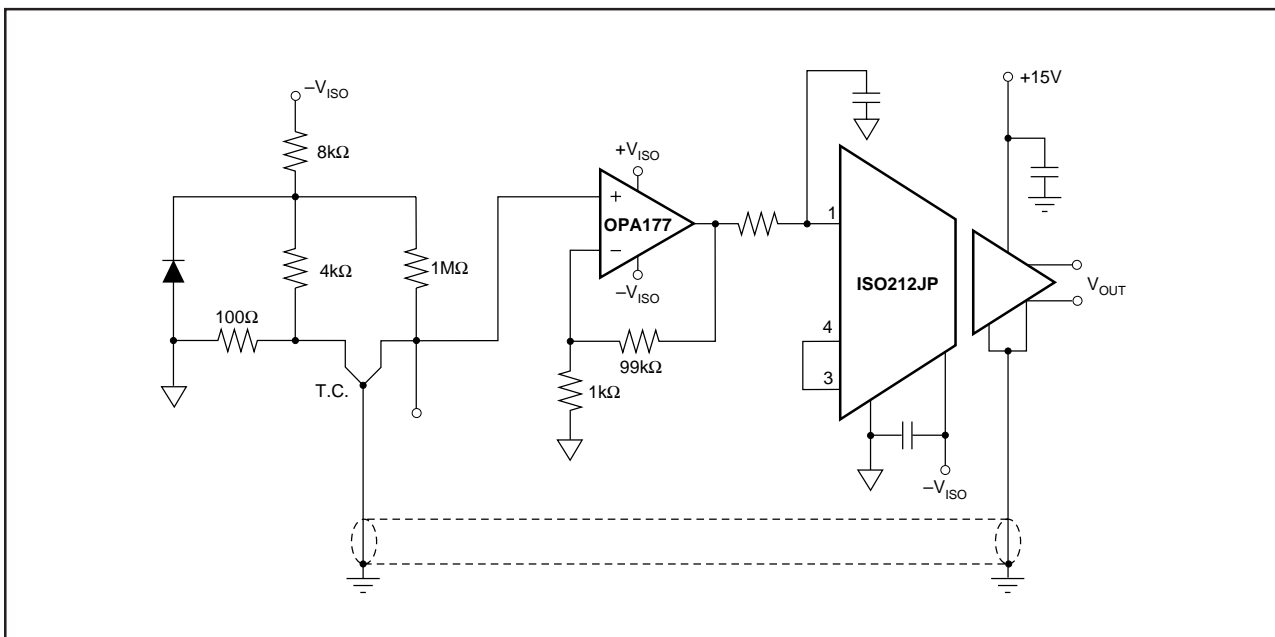

FIGURE 11. Thermocouple Amplifier with Ground Loop Elimination, Cold Junction Compensation and Down-Scale Burn-Out.

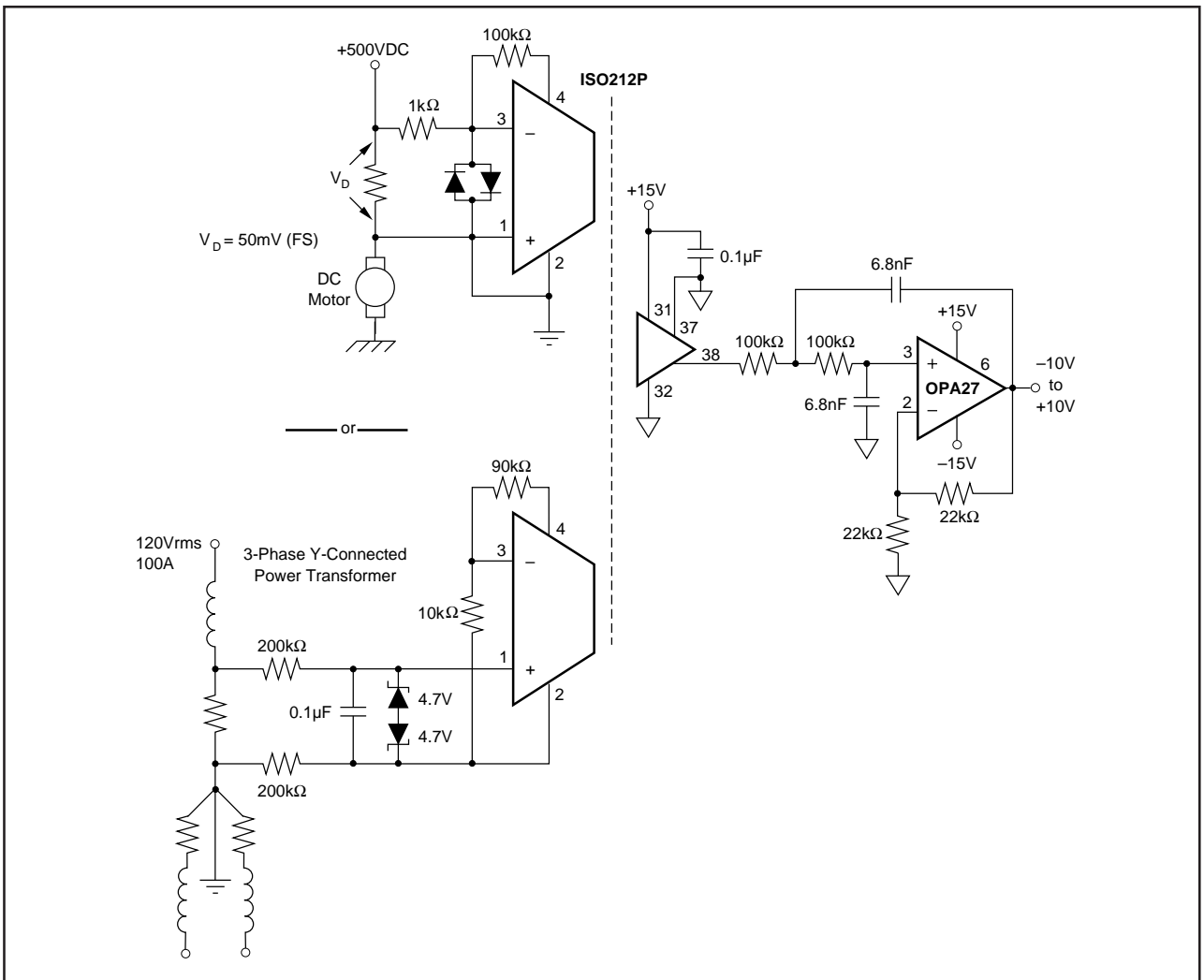

FIGURE 12. Isolated Current Monitoring Applications.

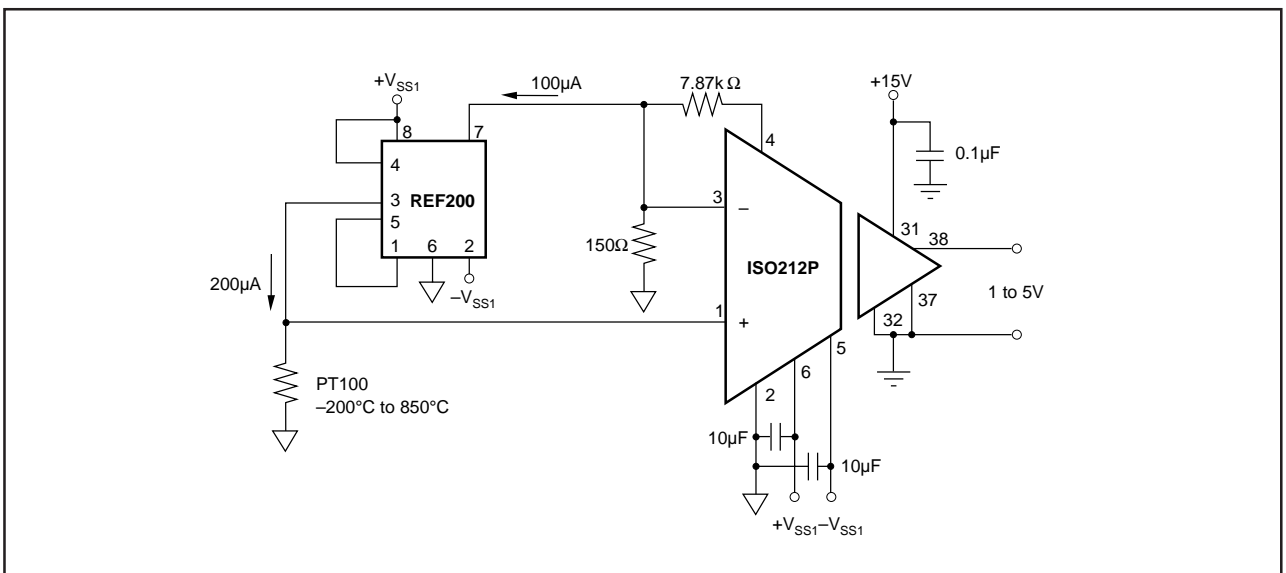

FIGURE 13. Isolated Temperature Sensing and Amplification.