

LM160,LM360

LM160/LM360 High Speed Differential Comparator



Literature Number: SNOSBJ4B

LM160/LM360 High Speed Differential Comparator

General Description

The LM160/LM360 is a very high speed differential input, complementary TTL output voltage comparator with improved characteristics over the μ A760/ μ A760C, for which it is a pin-for-pin replacement. The device has been optimized for greater speed, input impedance and fan-out, and lower input offset voltage. Typically delay varies only 3 ns for overdrive variations of 5 mV to 400 mV.

Complementary outputs having minimum skew are provided. Applications involve high speed analog to digital converters and zero-crossing detectors in disk file systems.

Features

- Guaranteed high speed: 20 ns max
- Tight delay matching on both outputs
- Complementary TTL outputs
- High input impedance
- Low speed variation with overdrive variation
- Fan-out of 4
- Low input offset voltage
- Series 74 TTL compatible

Connection Diagrams

Metal Can Package

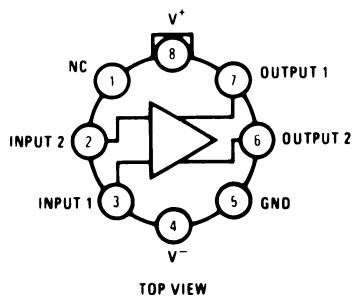

00570704

Order Number LM160H/883 (Note 1)
See NS Package Number H08C

Dual-In-Line Package

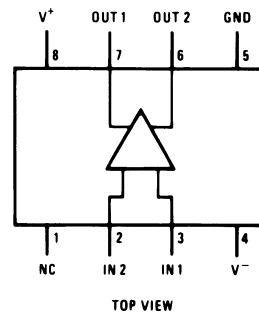

00570705

Order Number LM360M, LM360MX or LM360N
See NS Package Number M08A or N08E

Note 1: Also available in SMD# 5962-8767401

Absolute Maximum Ratings (Notes 6, 8)

If Military/Aerospace specified devices are required, please contact the National Semiconductor Sales Office/Distributors for availability and specifications.

Positive Supply Voltage	+8V
Negative Supply Voltage	-8V
Peak Output Current	20 mA
Differential Input Voltage	±5V
Input Voltage	$V^+ \geq V_{IN} \geq V^-$
ESD Tolerance (Note 9)	1600V
Operating Temperature Range	
LM160	-55°C to +125°C
LM360	0°C to +70°C

Storage Temperature Range	-65°C to +150°C
Lead Temperature	
(Soldering, 10 sec.)	260°C
Soldering Information	
Dual-In-Line Package	
Soldering (10 seconds)	260°C
Small Outline Package	
Vapor Phase (60 seconds)	215°C
Infrared (15 seconds)	220°C
See AN-450 "Surface Mounting Methods and Their Effect on Product Reliability" for other methods of soldering surface mount devices.	

Electrical Characteristics(T_{MIN} ≤ T_A ≤ T_{MAX})

Parameter	Conditions	Min	Typ	Max	Units
Operating Conditions					
Supply Voltage V _{CC} ⁺		4.5	5	6.5	V
Supply Voltage V _{CC} ⁻		-4.5	-5	-6.5	V
Input Offset Voltage	R _S ≤ 200Ω		2	5	mV
Input Offset Current			0.5	3	μA
Input Bias Current			5	20	μA
Output Resistance (Either Output)	V _{OUT} = V _{OH}		100		Ω
Response Time					
	T _A = 25°C, V _S = ±5V (Notes 2, 7)		13	25	ns
	T _A = 25°C, V _S = ±5V (Notes 3, 7)		12	20	ns
	T _A = 25°C, V _S = ±5V (Notes 4, 7)		14		ns
Response Time Difference between Outputs					
(t _{pd} of +V _{IN1}) - (t _{pd} of -V _{IN2})	T _A = 25°C (Notes 2, 7)		2		ns
(t _{pd} of +V _{IN2}) - (t _{pd} of -V _{IN1})	T _A = 25°C (Notes 2, 7)		2		ns
(t _{pd} of +V _{IN1}) - (t _{pd} of +V _{IN2})	T _A = 25°C (Notes 2, 7)		2		ns
(t _{pd} of -V _{IN1}) - (t _{pd} of -V _{IN2})	T _A = 25°C (Notes 2, 7)		2		ns
Input Resistance	f = 1 MHz		17		kΩ
Input Capacitance	f = 1 MHz		3		pF
Average Temperature Coefficient of Input Offset Voltage	R _S = 50Ω		8		μV/°C
Average Temperature Coefficient of Input Offset Current			7		nA/°C
Common Mode Input Voltage Range	V _S = ±6.5V	±4	±4.5		V
Differential Input Voltage Range		±5			V
Output High Voltage (Either Output)	I _{OUT} = -320 μA, V _S = ±4.5V	2.4	3		V
Output Low Voltage (Either Output)	I _{SINK} = 6.4 mA		0.25	0.4	V
Positive Supply Current	V _S = ±6.5V		18	32	mA
Negative Supply Current	V _S = ±6.5V		-9	-16	mA

Note 2: Response time measured from the 50% point of a 30 mVp-p 10 MHz sinusoidal input to the 50% point of the output.

Note 3: Response time measured from the 50% point of a 2 Vp-p 10 MHz sinusoidal input to the 50% point of the output.

Electrical Characteristics (Continued)

Note 4: Response time measured from the start of a 100 mV input step with 5 mV overdrive to the time when the output crosses the logic threshold.

Note 5: Typical thermal impedances are as follows:

Cavity DIP (J):	θ_{jA}	135°C/W	Header (H)	θ_{jA}	165°C/W	(Still Air)
Molded DIP (N):	θ_{jA}	130°C/W			67°C/W	(400 LF/min Air Flow)
				θ_{jC}	25°C/W	

Note 6: The device may be damaged if used beyond the maximum ratings.

Note 7: Measurements are made in AC Test Circuit, Fanout = 1

Note 8: Refer to RETS 160X for LM160H, LM160J-14 and LM160J military specifications.

Note 9: Human body model, 1.5 k Ω in series with 100 pF.

Typical Performance Characteristics

Offset Voltage

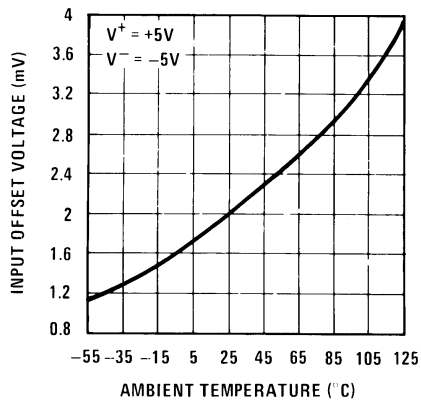

00570708

Input Current vs Ambient Temperature

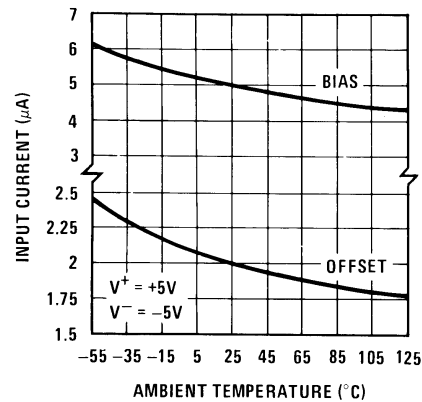

00570709

Input Characteristics

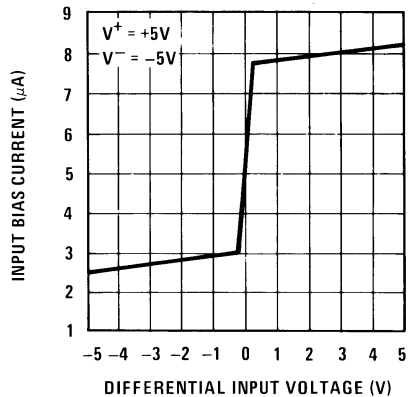

00570710

Supply Current vs Ambient Temperature

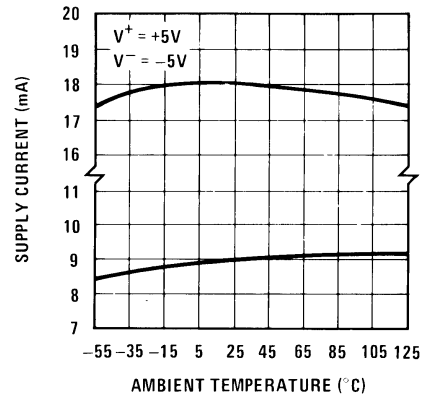

00570711

Typical Performance Characteristics (Continued)

Propagation Delay vs Ambient Temperature

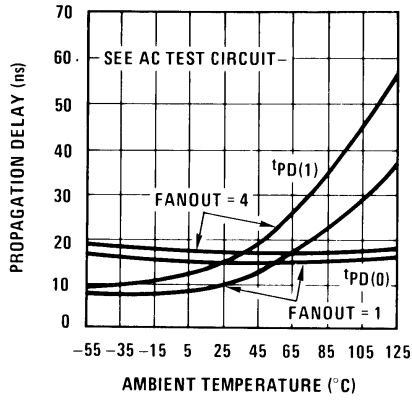

00570712

Delay of Output 1 With Respect to Output 2 vs Ambient Temperature

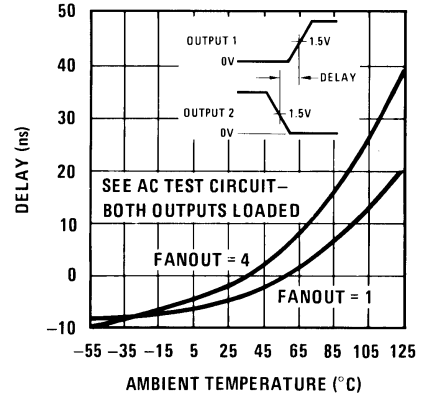

00570713

Common-Mode Pulse Response

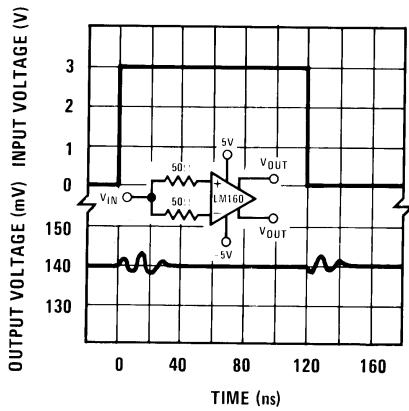

00570714

AC Test Circuit

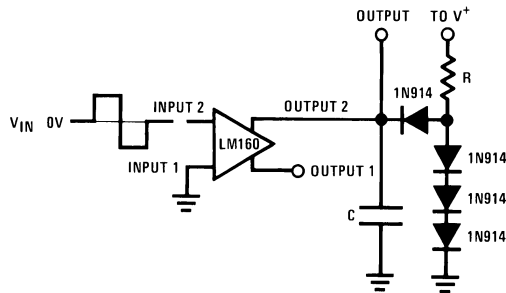

00570703

$V_{IN} = \pm 50 \text{ mV}$ FANOUT=1 FANOUT=4
 $V^+ = +5\text{V}$ $R = 2.4\text{k}$ $R = 630\Omega$
 $V^- = -5\text{V}$ $C = 15 \text{ pF}$ $C = 30 \text{ pF}$

Schematic Diagram

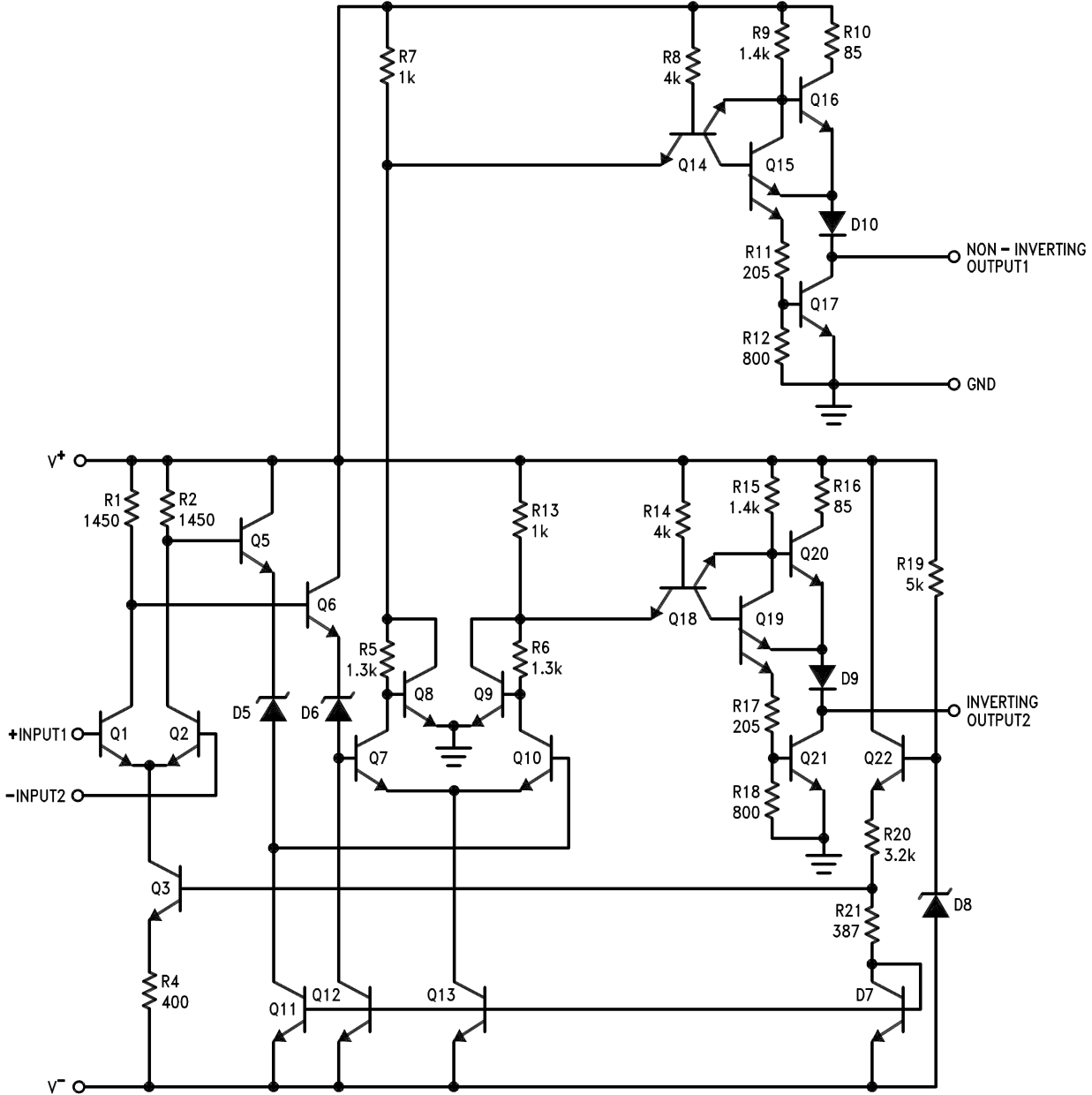

00570701

Physical Dimensions inches (millimeters)

unless otherwise noted

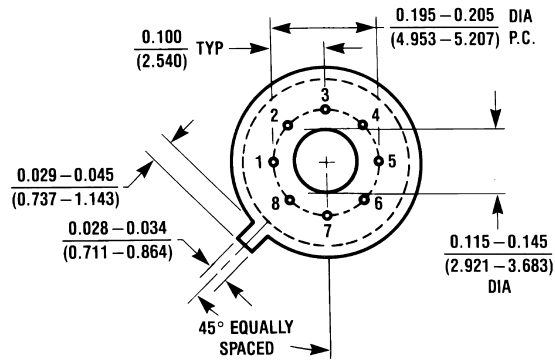
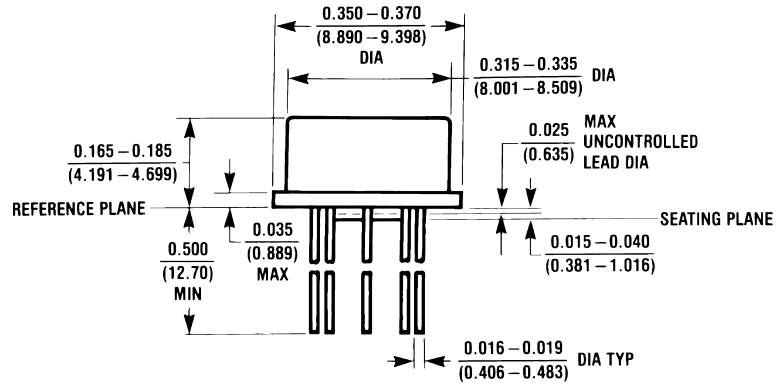

H08C (REV E)

Metal Can Package (H)
Order Number LM160H/883
NS Package Number H08C

Physical Dimensions inches (millimeters) unless otherwise noted (Continued)

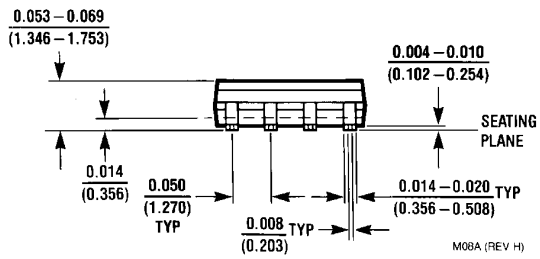
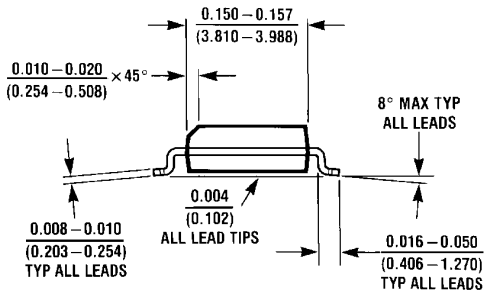
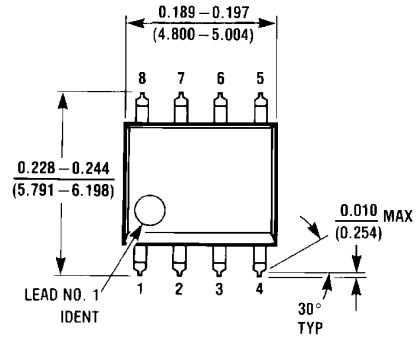

Molded Dual-In-Line Package (M)
Order Number LM360M or LM360MX
NS Package Number M08A

M08A (REV H)

Physical Dimensions inches (millimeters) unless otherwise noted (Continued)

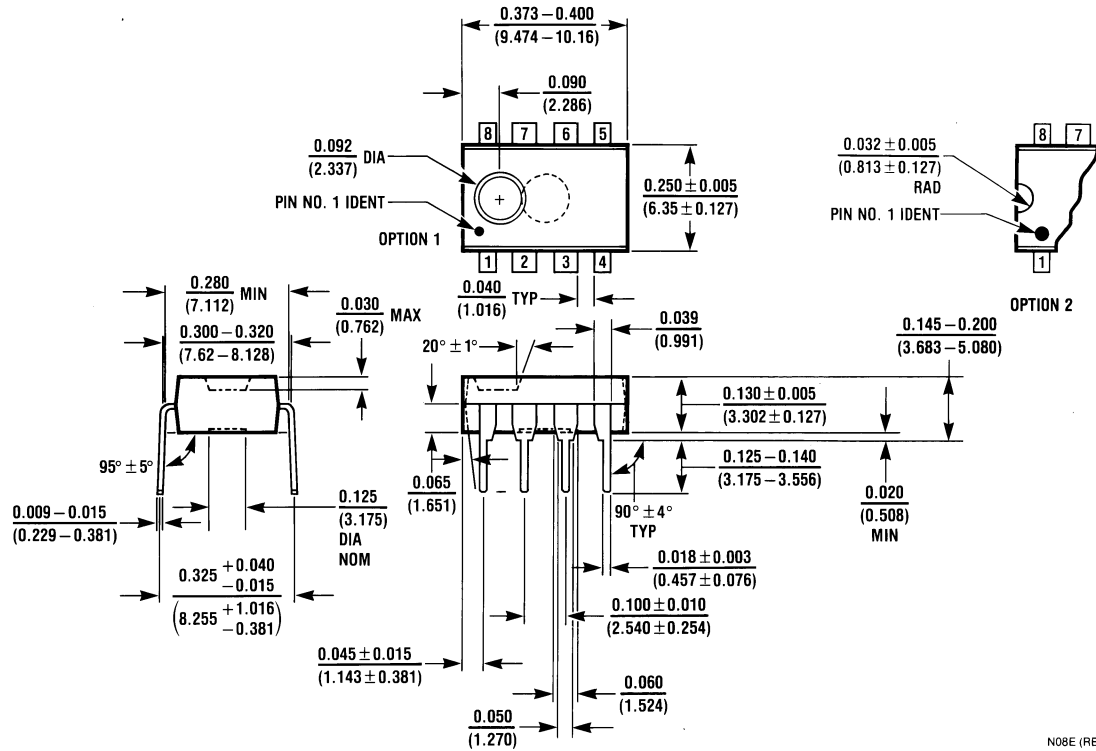

Molded Dual-In-Line Package (N)
Order Number LM360N
NS Package Number N08E

N08E (REV F)

National does not assume any responsibility for use of any circuitry described, no circuit patent licenses are implied and National reserves the right at any time without notice to change said circuitry and specifications.

For the most current product information visit us at www.national.com.

LIFE SUPPORT POLICY

NATIONAL'S PRODUCTS ARE NOT AUTHORIZED FOR USE AS CRITICAL COMPONENTS IN LIFE SUPPORT DEVICES OR SYSTEMS WITHOUT THE EXPRESS WRITTEN APPROVAL OF THE PRESIDENT AND GENERAL COUNSEL OF NATIONAL SEMICONDUCTOR CORPORATION. As used herein:

1. Life support devices or systems are devices or systems which, (a) are intended for surgical implant into the body, or (b) support or sustain life, and whose failure to perform when properly used in accordance with instructions for use provided in the labeling, can be reasonably expected to result in a significant injury to the user.
2. A critical component is any component of a life support device or system whose failure to perform can be reasonably expected to cause the failure of the life support device or system, or to affect its safety or effectiveness.

BANNED SUBSTANCE COMPLIANCE

National Semiconductor certifies that the products and packing materials meet the provisions of the Customer Products Stewardship Specification (CSP-9-111C2) and the Banned Substances and Materials of Interest Specification (CSP-9-111S2) and contain no "Banned Substances" as defined in CSP-9-111S2.

 **National Semiconductor**
Americas Customer Support Center
 Email: new.feedback@nsc.com
 Tel: 1-800-272-9959

National Semiconductor
Europe Customer Support Center
 Fax: +49 (0) 180-530 85 86
 Email: europe.support@nsc.com
 Deutsch Tel: +49 (0) 69 9508 6208
 English Tel: +44 (0) 870 24 0 2171
 Français Tel: +33 (0) 1 41 91 8790

National Semiconductor
Asia Pacific Customer Support Center
 Email: ap.support@nsc.com

National Semiconductor
Japan Customer Support Center
 Fax: 81-3-5639-7507
 Email: jpn.feedback@nsc.com
 Tel: 81-3-5639-7560

IMPORTANT NOTICE

Texas Instruments Incorporated and its subsidiaries (TI) reserve the right to make corrections, modifications, enhancements, improvements, and other changes to its products and services at any time and to discontinue any product or service without notice. Customers should obtain the latest relevant information before placing orders and should verify that such information is current and complete. All products are sold subject to TI's terms and conditions of sale supplied at the time of order acknowledgment.

TI warrants performance of its hardware products to the specifications applicable at the time of sale in accordance with TI's standard warranty. Testing and other quality control techniques are used to the extent TI deems necessary to support this warranty. Except where mandated by government requirements, testing of all parameters of each product is not necessarily performed.

TI assumes no liability for applications assistance or customer product design. Customers are responsible for their products and applications using TI components. To minimize the risks associated with customer products and applications, customers should provide adequate design and operating safeguards.

TI does not warrant or represent that any license, either express or implied, is granted under any TI patent right, copyright, mask work right, or other TI intellectual property right relating to any combination, machine, or process in which TI products or services are used. Information published by TI regarding third-party products or services does not constitute a license from TI to use such products or services or a warranty or endorsement thereof. Use of such information may require a license from a third party under the patents or other intellectual property of the third party, or a license from TI under the patents or other intellectual property of TI.

Reproduction of TI information in TI data books or data sheets is permissible only if reproduction is without alteration and is accompanied by all associated warranties, conditions, limitations, and notices. Reproduction of this information with alteration is an unfair and deceptive business practice. TI is not responsible or liable for such altered documentation. Information of third parties may be subject to additional restrictions.

Resale of TI products or services with statements different from or beyond the parameters stated by TI for that product or service voids all express and any implied warranties for the associated TI product or service and is an unfair and deceptive business practice. TI is not responsible or liable for any such statements.

TI products are not authorized for use in safety-critical applications (such as life support) where a failure of the TI product would reasonably be expected to cause severe personal injury or death, unless officers of the parties have executed an agreement specifically governing such use. Buyers represent that they have all necessary expertise in the safety and regulatory ramifications of their applications, and acknowledge and agree that they are solely responsible for all legal, regulatory and safety-related requirements concerning their products and any use of TI products in such safety-critical applications, notwithstanding any applications-related information or support that may be provided by TI. Further, Buyers must fully indemnify TI and its representatives against any damages arising out of the use of TI products in such safety-critical applications.

TI products are neither designed nor intended for use in military/aerospace applications or environments unless the TI products are specifically designated by TI as military-grade or "enhanced plastic." Only products designated by TI as military-grade meet military specifications. Buyers acknowledge and agree that any such use of TI products which TI has not designated as military-grade is solely at the Buyer's risk, and that they are solely responsible for compliance with all legal and regulatory requirements in connection with such use.

TI products are neither designed nor intended for use in automotive applications or environments unless the specific TI products are designated by TI as compliant with ISO/TS 16949 requirements. Buyers acknowledge and agree that, if they use any non-designated products in automotive applications, TI will not be responsible for any failure to meet such requirements.

Following are URLs where you can obtain information on other Texas Instruments products and application solutions:

Products

Audio	www.ti.com/audio
Amplifiers	amplifier.ti.com
Data Converters	dataconverter.ti.com
DLP® Products	www.dlp.com
DSP	dsp.ti.com
Clocks and Timers	www.ti.com/clocks
Interface	interface.ti.com
Logic	logic.ti.com
Power Mgmt	power.ti.com
Microcontrollers	microcontroller.ti.com
RFID	www.ti-rfid.com
OMAP Mobile Processors	www.ti.com/omap
Wireless Connectivity	www.ti.com/wirelessconnectivity

Applications

Communications and Telecom	www.ti.com/communications
Computers and Peripherals	www.ti.com/computers
Consumer Electronics	www.ti.com/consumer-apps
Energy and Lighting	www.ti.com/energy
Industrial	www.ti.com/industrial
Medical	www.ti.com/medical
Security	www.ti.com/security
Space, Avionics and Defense	www.ti.com/space-avionics-defense
Transportation and Automotive	www.ti.com/automotive
Video and Imaging	www.ti.com/video

TI E2E Community Home Page

e2e.ti.com

Mailing Address: Texas Instruments, Post Office Box 655303, Dallas, Texas 75265
Copyright © 2011, Texas Instruments Incorporated