

# Sensor Amplifier Monolithic IC MM1089

## Outline

This IC is an amplifier with a high-impedance differential input, which can be used in high-CMR instrumentation. Particularly when amplifying signals from a high-impedance or high-bias signal source, often signals are buried in noise, making amplification difficult. This IC amplifies only the signal, and the noise is suppressed rather than amplified, making it effective for use where noise is prominent or with high-impedance signal sources.

## Features

- |  |                             |
|--|-----------------------------|
| 1. Battery charge/discharge current detection<br>(for laptops, word processors, etc) | 80dB min., 100dB typ.       |
| 2. Signal amplifiers for magnetic sensors, pressure sensors, strain gauges           | Except 10MΩ                 |
| 3. Instrumentation amps  | ×3~×100                     |
| 4. Broad input range   | -0.3V~V <sub>CC</sub> +0.3V |
| 5. Two internal channels   |                             |

## Package

SOP-18A (MM1089XF)

## Applications

- 1 Detection of battery charge/discharge current (for notebook computers, word processors etc)
- 2 Amplification of magnetic sensor, pressure sensor, strain gauge, other signals
- 3 Instrumentation amp

Pin Assignment

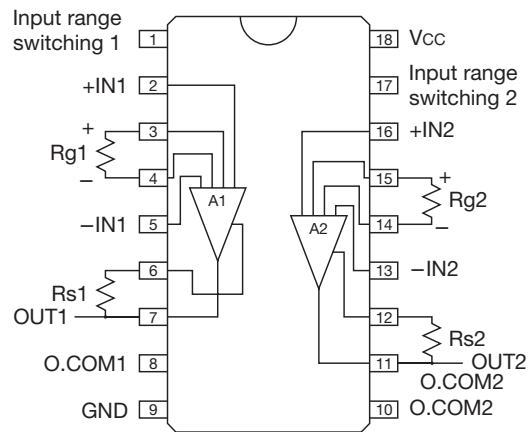

Pin no.	Pin name	Function
1	Input range switching 1 INCHG1	AMP1 Input voltage range switching Hi : 1.8V~V <sub>CC</sub> +0.3V LO : -0.3V~V <sub>CC</sub> -1.8V
2	IN1+	AMP1 +Input
3	Rg1+	AMP1 Resistance to set the Rg gain
4	Rg1-	AMP1 Resistance to set the Rg gain
5	IN1-	AMP1 -Input
6	Rs1	AMP1 Resistance to set the Rs gain
7	OUT1	AMP1 Resistance to set the Rs gain, output 1
8	O.COM1	AMP1 Common output
9	GND	Ground
10	O.COM2	AMP2 Common output
11	OUT2	AMP2 Resistance to set the Rs gain, output 2
12	Rs2	AMP2 Resistance to set the Rs gain
13	IN2-	AMP2 -Input
14	Rg2-	AMP2 Resistance to set the Rg gain
15	Rg2+	AMP2 Resistance to set the Rg gain
16	IN2+	AMP2 +Input
17	Input range switching 2 INCHG2	AMP2 Input voltage range switching Hi : 1.8V~V <sub>CC</sub> +0.3V Lo : -0.3V~V <sub>CC</sub> -1.8V
18	V <sub>CC</sub>	Power supply input

**Equivalent Circuit Diagram**

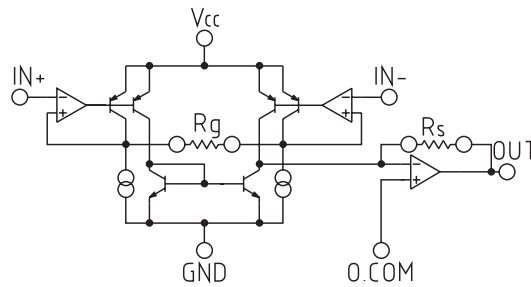

**Absolute Maximum Ratings** (Ta=25°C)

Item	Symbol	Ratings	Units
Operating temperature	T <sub>OPR</sub>	-20~+70	°C
Storage temperature	T <sub>STG</sub>	-40~+125	°C
Power supply voltage	V <sub>CC</sub>	-0.3~+25	V
Allowable loss	P <sub>d</sub>	350	mW

**Electrical Characteristics** (Except where noted otherwise, Ta=25°C, Vcc=15V, Rg=10kΩ, Rs=1000kΩ)

Item	Symbol	Measurement conditions	Min.	Typ.	Max.	Units
Consumption current	I <sub>CC</sub>			0.45	0.6	mA
Gain	G <sub>V</sub>	$G_V = K \times R_s / R_g$	See Fig. 1			
Gain error	$\Delta G_V$	Error of above formula	-5	0	+5	%
Input bias current 1	I <sub>B1</sub>	When input range switching pin is high		50	250	nA
Input bias current 2	I <sub>B2</sub>	When input range switching pin is low		-100	-500	nA
Input offset current	I <sub>IO</sub>			5	50	nA
Input offset voltage	V <sub>IO</sub>		-2	0	+2	mV
O.COM pin setting voltage range	V <sub>OC</sub>	Output takes O.COM pin voltage as reference	1.0		V <sub>CC</sub> -1.5	V
O.COM pin input bias current	I <sub>OC</sub>			-50		nA
		MM1089		-100		
		MM1131				
Output offset voltage	V <sub>OO</sub>	V <sub>OC</sub> as reference (G <sub>V</sub> =40dB)	-0.25	0	+0.25	V
Output offset current	I <sub>OO</sub>	V <sub>OC</sub> as reference (G <sub>V</sub> =40dB)	-0.25	0	+0.25	μA
Common-mode input range 1	V <sub>ICM1</sub>	When input range switching pin is high	1.8		V <sub>CC</sub> +0.3	V
Common-mode input range 2	V <sub>ICM2</sub>	When input range switching pin is low	-0.3		V <sub>CC</sub> -1.8	V
Input voltage high level for input range switching pin	V <sub>HSW</sub>		2.4			V
Input voltage low level for input range switching pin	V <sub>LSW</sub>				0.8	V
Input current (Hi) for input range switching pin	I <sub>HSW</sub>	V <sub>INSW</sub> =15V	-1		1	μA
Input current (Lo) for input range switching pin	I <sub>LSW</sub>	V <sub>INSW</sub> =0V	-5		-0.5	μA
Output outflow current	I <sub>SOURC</sub>	V <sub>IN(+)</sub> -V <sub>IN(-)</sub> =+1V, V <sub>O</sub> =V <sub>CC</sub> -1.5V O.COM=5V	1.0	4.0		mA
Output inflow current	I <sub>SINK</sub>	V <sub>IN(+)</sub> -V <sub>IN(-)</sub> =-1V, V <sub>O</sub> =0.3V O.COM=5V	0.3	1.0		mA
Slew rate	SR			0.16		V/μS
Common-mode signal rejection ratio	CMR	DC	80	100		dB
Power supply fluctuation rejection ratio	SVR	DC	80	100		dB
Input equivalent noise voltage	V <sub>NI</sub>	R <sub>IN</sub> =1kΩ, BPF=20Hz~20kHz		6		μV

Characteristics

Common-mode input voltage range

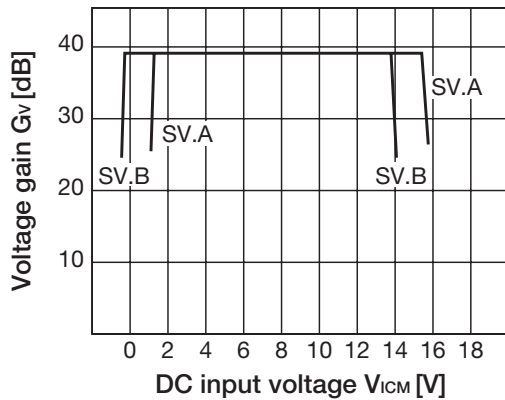

Voltage gain vs frequency characteristic

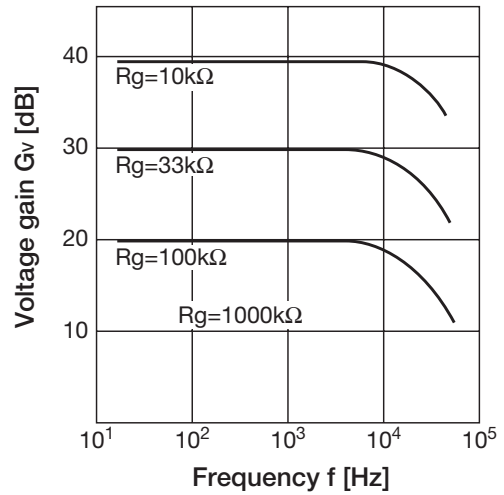

Consumption voltage vs power supply voltage

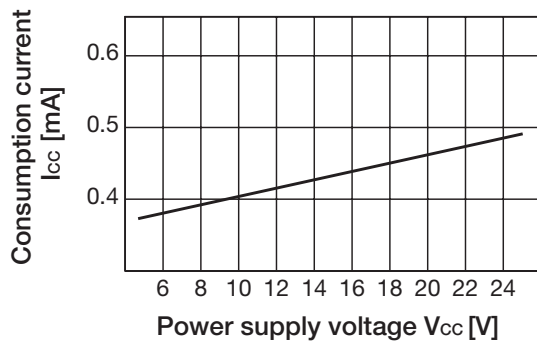

Maximum output voltage vs Re

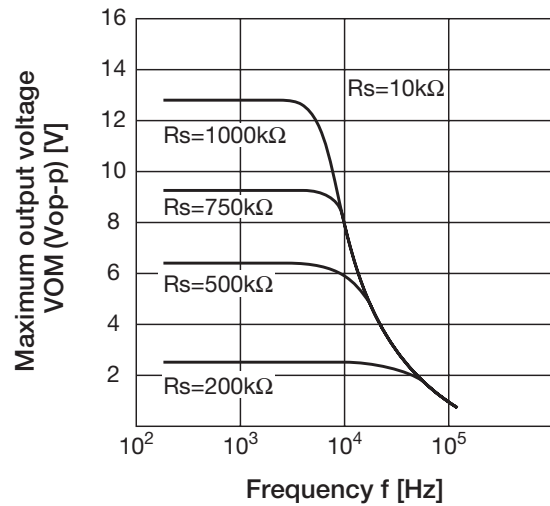

Power supply fluctuation rejection ratio vs frequency

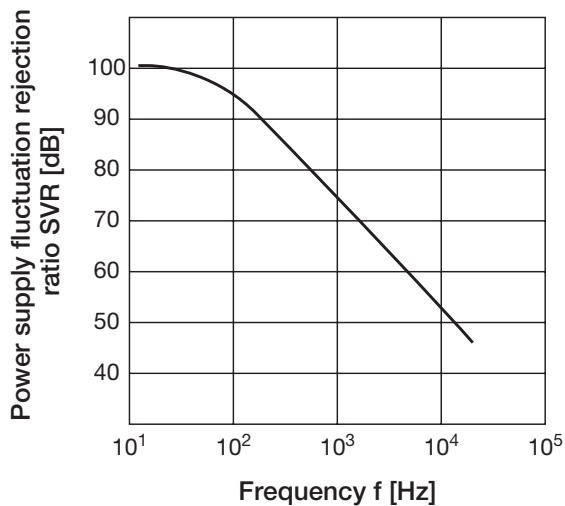

Common mode component rejection ratio vs frequency

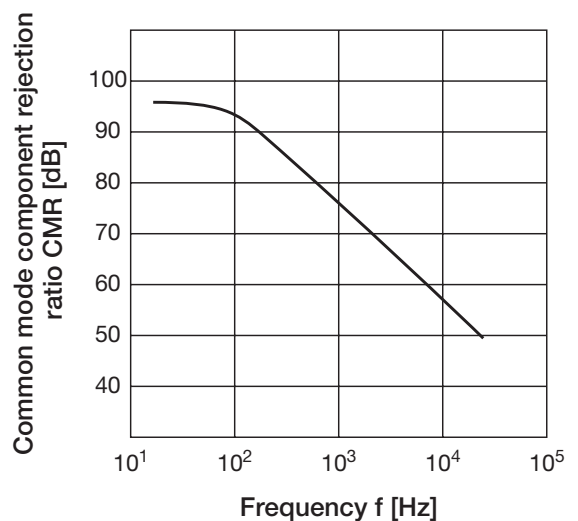

Gain Settings

1. By mounting appropriate external  $R_s$  and  $R_g$  resistances, a subtractive amp can easily be configured with a gain  $G_v = K \times R_s / R_g$  (where  $K=1$  typ.).

Here the precision of  $R_s$  and  $R_g$  affects the gain, but has no inherent effect on CMR.

However, the practical range for the gain is  $G_v=3$  to 100.

2. To determine  $R_s$  and  $R_g$ , first  $R_s$  is calculated from the maximum required output voltage; then the equation for the gain  $G_v = K \times R_s / R_g$  is used to compute  $R_g$ .

The voltage gain coefficient  $K$  varies with the value of  $R_g$ . For approximate values of  $K$  see Fig.1. The larger the value of  $R_s$ , the larger is the output offset voltage.

If  $R_s$  is made small, an advantageous offset voltage is obtained, but if it is too small, an adequate maximum output voltage is not obtained.

As a rough estimate, when the maximum output voltage is to be  $10V_{P-P}$ ,  $R_s=1000k\Omega$ ; if it is to be  $5V_{P-P}$ , then  $R_s=500k\Omega$ .

- Recommended values: When  $R_s=1000\text{ k}\Omega$ ,  $G_v=100$ ,  $R_g=9.1k\Omega$
- When  $R_s=1000\text{ k}\Omega$ ,  $G_v=50$ ,  $R_g=18k\Omega$
- When  $R_s=500k\Omega$ ,  $G_v=50$ ,  $R_g=9.1k\Omega$
- When  $R_s=500k\Omega$ ,  $G_v=10$ ,  $R_g=47k\Omega$

3. The output offset voltage ratings in the table of electrical characteristics are for  $R_g=10k\Omega$ ,  $R_s=1000k\Omega$ .

When using other constants, use the following formula for the output offset:

$$\text{Output offset} = V_{IO} \times G_v + I_{OO} \times R_s$$

4. The output voltage is essentially the voltage applied to the O.COM (OUTPUT COMMON) pin, output as the reference level. In actuality, an offset is added to the reference potential and output.

Because the O.COM pin is independent of both amps 1 and 2, offset adjustment is easily accomplished by shifting the O.COM pin voltage by the amount of the offset.

5. If the input range switching pin is set high, the input voltage range is covered from the  $V_{CC}$  level; by switching it to low, the range extends from GND level.

However, the offsets are different, so care must be taken in continuous switching.

6. The O.COM pin setting voltage range and common-mode input range should be set to voltages between the minimum and maximum values.

[Voltage gain coefficient K vs.  $R_g$ ]

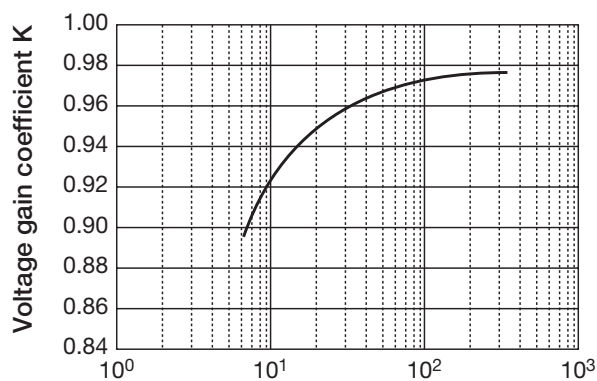
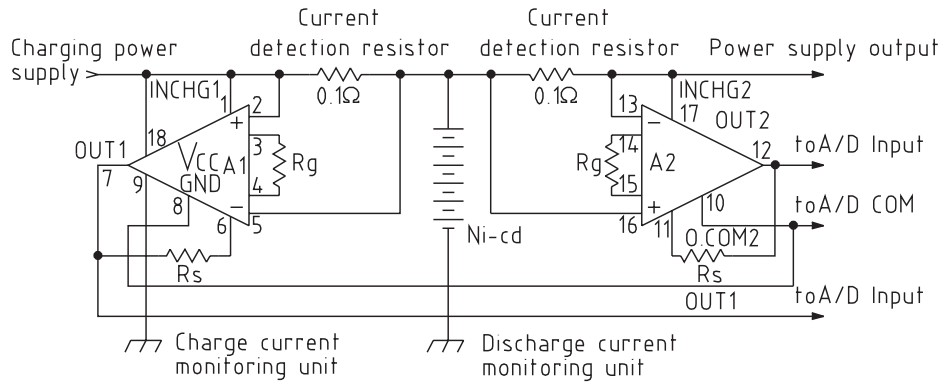

Fig. 1  $R_g$  (kΩ) — MM1089

**Application Circuits**

1. Charger for NiCad batteries (charging current, discharge current detection circuit)



Note : For the Rg and Rs resistances, see "Gain Settings"

2. Charger for NiCad batteries (charging current, discharge current detection circuit)

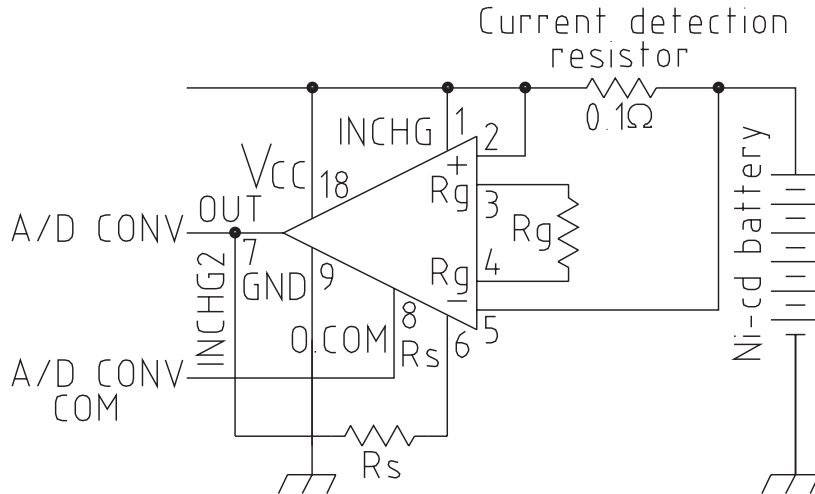

Note : For the Rg and Rs resistances, see "Gain Settings"

3. Sensor signal amplification

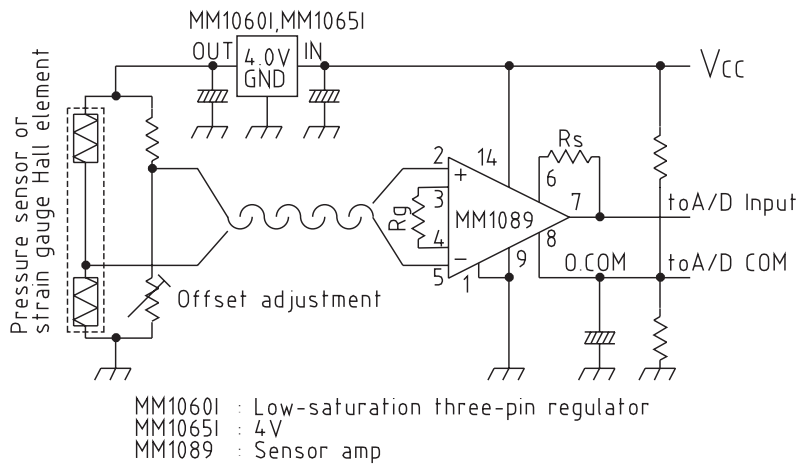

Note : For the Rg and Rs resistances, see "Gain Settings"

1. Summary

An instrumentation amp is often used as a sensor amp to amplify weak signals. Among the advantages of such an amplifier are

1. Good CMR characteristics
2. High input impedance
3. Means of gain adjustment which does not affect the CMR characteristic

However, in practice an extremely high resistance precision is demanded, making it difficult to implement such an amplifier at low cost. In order to eliminate these problems, Mitsumi developed the MM1089 sensor amp, with a circuit configuration providing the above advantages using ordinary monolithic IC precision.

2. Aim of development

The I/O environment in which this IC will be used was expected to include input sources ranging from GND to  $V_{CC}$ , while devices receiving the IC output were anticipated to consist mainly of microcomputers with integrated D/A converters. In addition to a high CMR characteristic, the offset voltage must be kept low; here it was judged that the output voltage with no input signal could be easily read in advance and used in the microcomputer to correct measured values, so that no measures are taken to force down the offset voltage unnecessarily. Of course even if a microcomputer is not used, a potentiometer can be used to shift the reference voltage applied to the O.COM pin by the amount of the offset. Emphasis was placed on a high CMR characteristic and the ability to accommodate a wide range of input voltages.

3. Features of the MM1089

1. CMR characteristic of 100dB and higher
2. Input impedance of 10MΩ and above
3. Broad recommended operating power supply voltage range (4.5V to 20V using a single power supply)
4. Broad input voltage range (-0.3V to  $V_{CC}+0.3V$ )
5. Range can be set freely (between 10 and 40dB) using two external resistances
6. Reference voltage applied to O.COM pin can be set over a broad range (1V to  $V_{CC}-1.5V$ )

4. Configuration and summary of operation

4-1. Means to achieve high CMR characteristic and circuit operation

As explained above, the machining precision of ordinary monolithic ICs (with a resistance precision of 2%) is such that a high CMR characteristic cannot be easily obtained in an instrumentation amplifier.

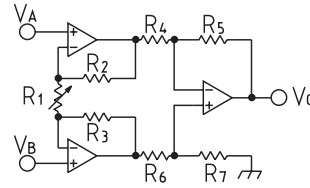

When  $V_A = V_C - \frac{V_D}{2}$  is defined as  $V_B = V_C + \frac{V_D}{2}$   
 (Provided that in-phase input component  $V_D$ : negative phase input component)  

$$V_O = \frac{R_4 R_7 - R_5 R_6}{R_4 (R_6 + R_7)} V_C + \left\{ \frac{R_7 (R_4 + R_5)}{R_4 (R_6 + R_7)} \left( 1 + \frac{2R_3}{R_1} \right) + \frac{R_5}{R_4} \left( 1 + \frac{2R_2}{R_1} \right) \right\} \frac{V_D}{2}$$

Fig. 1. Ordinary instrumentation amp

In Fig.1, in a circuit configuration with a gain of 40dB, a resistance precision of 0.1% is necessary for a CMR of 100dB; for a gain of 20dB, the precision must be 0.01%. Hence in this IC a circuit configuration based on an entirely different operating principle was employed. The approach is simple: the transistor  $I_C$  vs.  $V_{CE}$  characteristic is a constant-current characteristic not readily dependent on the voltage. Hence the input signal voltage is converted into a current signal in the input unit, and the current component is passed to the output circuit.

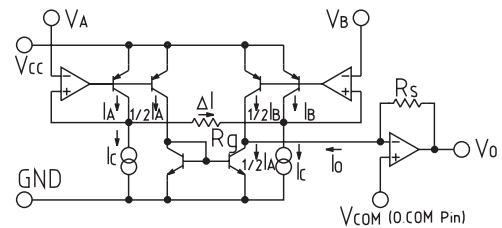

$$V_O = V_{COM} + I_O \cdot R_S$$

one side  $V_A - V_B = \Delta I \cdot R_g$   
 $I_A = I_C + \Delta I$   
 $I_B = I_C - \Delta I$   
 $I_O = 1/2 I_A - 1/2 I_B = \Delta I$   
 therefore  $V_O = V_{COM} + \Delta I \cdot R_S = V_{COM} + (V_A - V_B) \cdot R_S \cdot R_g$

Fig.2. Basic circuit illustrating operation

Figure 2 shows the basic circuit.

A simple buffer amp is used to generate a difference voltage for the input signal across the resistance  $R_g$ , which determines the gain, and the current  $\Delta I$  flowing in this resistance is passed through a current mirror circuit before reaching  $R_s$  of the output amp, to obtain an output voltage  $\Delta I \times R_s$ .

The overall gain is  $R_s/R_g$ . The output from the amp acting as an input buffer depends on two PNP transistors. The first transistor is connected to one end of the resistor  $R_g$ , a constant-current power supply, and a feedback loop; the second PNP transistor has an emitter area only one-half that of the former transistor, and is connected to a current mirror circuit and an output circuit.

By this means, an output  $V_{OUT}$  is obtained consisting of the reference voltage  $V_{COM}$  applied to one of the input pins of the output amp, on which

is superposed the input difference voltage  $\times R_s/R_g$ . The common mode level of the input signal does not appear in the basic equation, meaning that an amplifier with an inherently very high CMR characteristic can be obtained. Of course in the basic circuit considered here, because of the Early effect of the transistors the current mirror circuit operation will not be ideal, and the CMR characteristic values are as yet insufficient. In the actual circuit, cascade connections suppress the Early effect, and a current mirror circuit with an extremely small voltage dependence was adopted. Further, a differential amp was not used as the input buffer amp; instead, a simple configuration was used to obtain the required characteristics. Through these circuit designs, a CMR characteristic in excess of 100dB using standard values was achieved.

(4-2) Means to obtain a broad input voltage range, and circuit operation

One unavoidable problem is the transistor  $V_{BE}$  voltage, so that an input circuit which can handle all voltages from GND to  $V_{CC}$  is inherently impossible. If a resistance is used to attenuate the input, a broad range can be achieved; but then the input impedance cannot be kept high, deviating from the original development goals. In actual environments of use there are likely to be extremely few signal sources with signals varying continuously from GND to  $V_{CC}$ , and so a design was adopted in which it is possible to switch between a mode with an input voltage range of  $-0.3V$  to  $V_{CC}-1.8V$ , and a mode with input voltages ranging from  $1.8V$  to  $V_{CC}+0.3V$ . A switching pin was provided for this purpose. Specifically, the NPN emitter follower has an input circuit to shift the voltage in the negative direction, and the PNP emitter follower has an input circuit to shift the voltage in the positive direction; these are switched during use. Because the input offset voltage is different for the NPN and PNP inputs, in applications requiring switching during operation some special measures may be required for offset correction.

(4-3) Output circuit and operation

A standard op-amp circuit configuration with a B-class output stage is adopted. The potential applied to the +input (O.COM pin) is output as the reference potential.

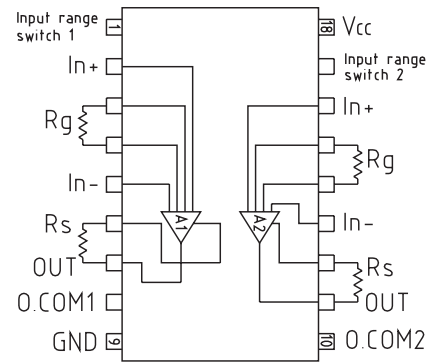

Fig.3. Pinout

To summarize the block diagram of Fig.3 and pin functions,

1. There are two circuits in a SOP-18P package.
2.  $R_g$  and  $R_s$  are external resistances.  $R_g$  is used to set the sensitivity, with smaller resistances yielding higher sensitivity.  $R_s$  is used to set the output scale; to obtain a larger output range, choose a higher resistance.  $R_s/R_g$  is the total gain. In actuality, there is a degree of error, and so a coefficient  $K$  is included (cf. Fig. 6).
3. The common voltage of the output circuit is applied to the O.COM pin; when the differential input is zero, the common voltage is output without modification (of course the offset voltage is added).

When there is a differential input, the output voltage  $V_o$  is

$$V_o = V_d \times R_s/R_g \times K + V_c + V_{of}$$

where  $V_d$  is the differential input voltage,  $V_c$  is the common voltage applied to the O.COM pin, and  $V_{of}$  is the offset voltage. On startup the offset amount is determined automatically, and when adding correction  $V_{COM}$  less the offset voltage is applied.

4. Input range switching pins

When the low potential is applied, the input range from  $-0.3V$  to  $V_{CC}-1.8V$  is covered, when high, the input range is  $+1.8V$  to  $V_{CC}+0.3V$ .

Switching at TTL level is possible. However, it should be noted that the input offset voltages are different for the two ranges. Of course if the IC is to be used fixed at one range, the switching pin can be shorted to GND or to  $V_{CC}$ .

5. Major performance parameters

1. Differential gain vs CMR characteristic

Differential gain vs CMR appears in Fig. 4.

When the gain of an ordinary instrumentation amp is lowered the CMR generally falls, but in this IC there is almost no change.



2. Input voltage range vs gain

Shown in Fig. 5. By switching the range using the input range switching pin, input from GND level to V<sub>CC</sub> level is provided.

3. Voltage gain coefficient K vs R<sub>g</sub>

R<sub>s</sub>/R<sub>g</sub> nearly coincides with the voltage gain, with a slight difference. This difference is represented by K, but as R<sub>g</sub> changes K also changes. This relationship is indicated in Fig. 6.

The output from the MM1089 may be passed through an A/D converter and input to a microcomputer for offset correction; an example appears in Fig.7. Here the inputs IN A and IN B are signal sources with input voltage ranges extending to GND level, while IN C and IN D are inputs which extend to V<sub>CC</sub> level.

1. An analog switch is used to input IN A to both input pins, the other switches are turned off. A control output is used to apply the "L" level to the input range switching pin. Here the output is V<sub>COM</sub>+V<sub>OFA</sub>, and this is read by the microcomputer and stored as V<sub>A</sub>.
2. Next, an analog switch is used to input IN C to both input pins; other switches are turned off. Here the input range switching pin is set to "H" by the control output. The output at this time is V<sub>COM</sub>+V<sub>OFB</sub>, and this is read by the microcomputer and stored as V<sub>B</sub>. The above are preparatory measurements.
3. Analog switches are set so that IN A is at one input, and IN B at the other; the other switches are turned off. The control output sets the input range switching pin to "L" level. Here the measured value V<sub>X1</sub> is the output voltage V<sub>O1</sub> less the previously determined V<sub>A</sub>.  

$$V_{X1} = V_{O1} - V_A = (IN\ A - IN\ B) \times G_V$$
4. Analog switches are set to input IN C to one input pin and IN D to the other; the other switches are turned off. The input range switching pin is set "H" by the control output. The measured value V<sub>X2</sub> is the output voltage V<sub>O2</sub> less the previous V<sub>B</sub>.  

$$V_{X2} = V_{O2} - V_B = (IN\ C - IN\ D) \times G_V$$

7. Summary

As explained above, an amplifier which is simple yet has a high CMR can be configured using the MM1089.

The MM1089 used together with a CPU equipped with an internal D/A converter should find a broad range of applications.

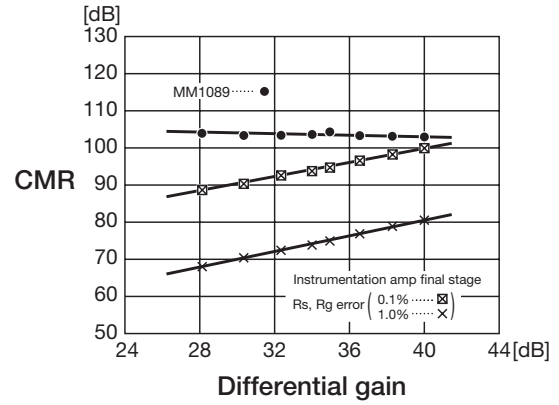

Fig.4. CMR vs differential gain

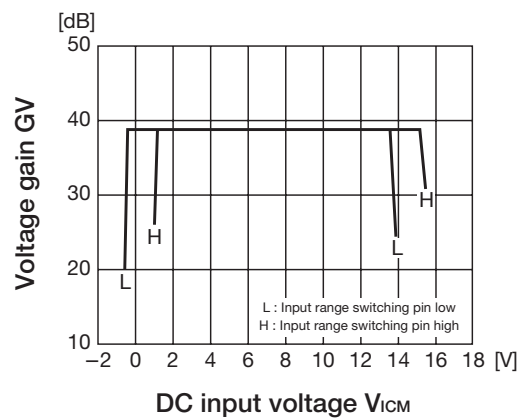

Fig.5. Common mode input voltage range

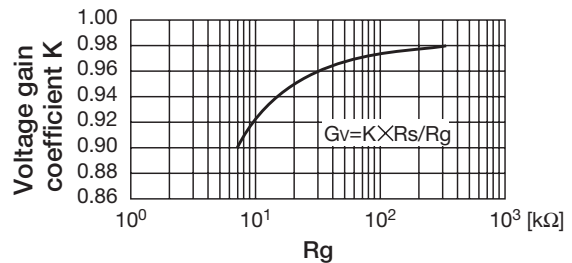

Fig.6. Voltage gain coefficient K vs R<sub>g</sub>

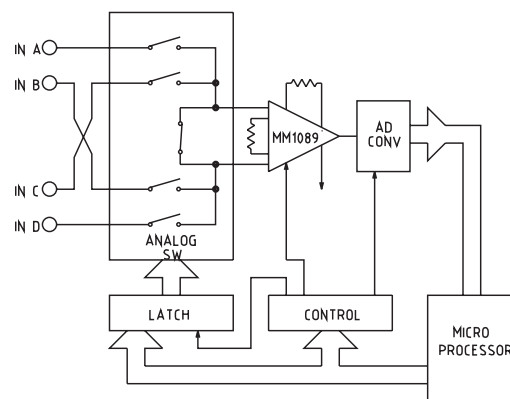

Fig.7. Application example