



# PRELIMINARY MX29L1611

## 16M-BIT [2M x 8/1M x 16] CMOS SINGLE VOLTAGE PAGEMODE FLASH EEPROM

### FEATURES

- Regulated voltage range 3.0 to 3.6V write, erase and read(MX29L1611-75/10/12)
- Fast random access/page mode access time: 75/30ns, 100/30ns, 120/30ns.
- Full voltage range 2.7 to 3.6V write, erase and read (MX29L1611-90)
- Fast random access/page mode access time: 90/35ns
- Endurance: 10,000 cycles
- Page access depth: 16 bytes/8 words, page address A0, A1, A2
- Sector erase architecture
  - 32 equal sectors of 64k bytes each
  - Sector erase time: 200ms typical
- Auto Erase and Auto Program Algorithms
  - Automatically erases any one of the sectors or the whole chip with Erase Suspend capability
  - Automatically programs and verifies data at specified addresses
- Status Register feature for detection of program or erase cycle completion
- Low VCC write inhibit  $\leq 1.8V$
- Software and hardware data protection
- Page program operation
  - Internal address and data latches for 128 bytes/64 words per page
  - Page programming time: 5ms typical
- Low power dissipation
  - 50mA active current
  - 20uA standby current
- Two independently Protected sectors
- Industry standard surface mount packaging
  - 44 lead SOP, 48 TSOP(I)

### GENERAL DESCRIPTION

The MX29L1611 is a 16-mega bit pagemode Flash memory organized as either 1M wordx16 or 2M bytex8. The MX29L1611 includes 32 sectors of 64KB(65,536 Bytes or 32,768 words). MXIC's Flash memories offer the most cost-effective and reliable read/write non-volatile random access memory and fast page mode access. The MX29L1611 is packaged 44-pin SOP and 48-TSOP(I). It is designed to be reprogrammed and erased in-system or in-standard EPROM programmers.

The standard MX29L1611 offers access times as fast as 100ns, allowing operation of high-speed microprocessors without wait. To eliminate bus contention, the MX29L1611 has separate chip enable  $\overline{CE}$ , output enable ( $\overline{OE}$ ), and write enable ( $\overline{WE}$ ) controls.

MXIC's Flash memories augment EPROM functionality with in-circuit electrical erasure and programming. The MX29L1611 uses a command register to manage this functionality.

To allow for simple in-system reprogrammability, the MX29L1611 does not require high input voltages for programming. Three-volt-only commands determine the operation of the device. Reading data out of the device is similar to reading from an EPROM.

MXIC Flash technology reliably stores memory contents even after 10,000 cycles. The MXIC's cell is designed to optimize the erase and programming mechanisms. In addition, the combination of advanced tunnel oxide processing and low internal electric fields for erase and programming operations produces reliable cycling. The MX29L1611 uses a 2.7V~3.6V VCC supply to perform the Auto Erase and Auto Program algorithms.

The highest degree of latch-up protection is achieved with MXIC's proprietary non-epi process. Latch-up protection is proved for stresses up to 100 milliamps on address and data pin from -1V to VCC +1V.

## PIN CONFIGURATIONS

### 44 SOP(500mil)

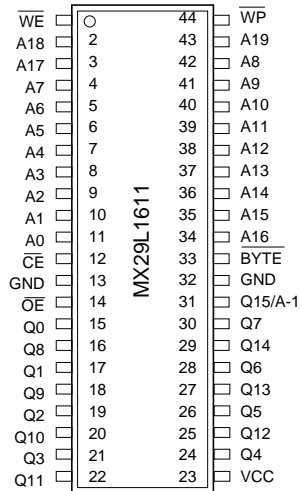

## PIN DESCRIPTION

SYMBOL	PIN NAME
A0 - A19	Address Input
Q0 - Q14	Data Input/Output
Q15/A-1	Q15(Word mode)/LSB addr.(Byte mode)
$\overline{CE}$	Chip Enable Input
$\overline{OE}$	Output Enable Input
$\overline{WE}$	Write Enable Input
$\overline{WP}^*$	Sector Write Protect Input
$\overline{BYTE}$	Word/Byte Selection Input
VCC	Power Supply
GND	Ground Pin

\*Only for 44-SOP

### 48 TSOP (NORMAL TYPE)

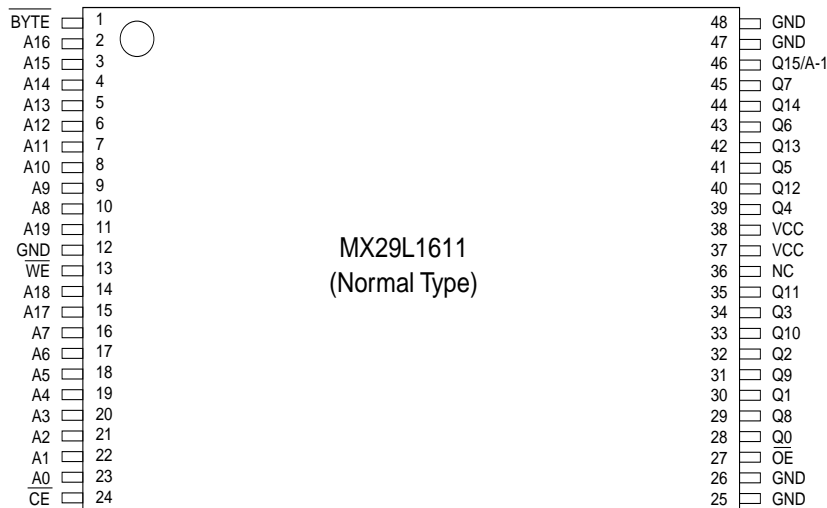

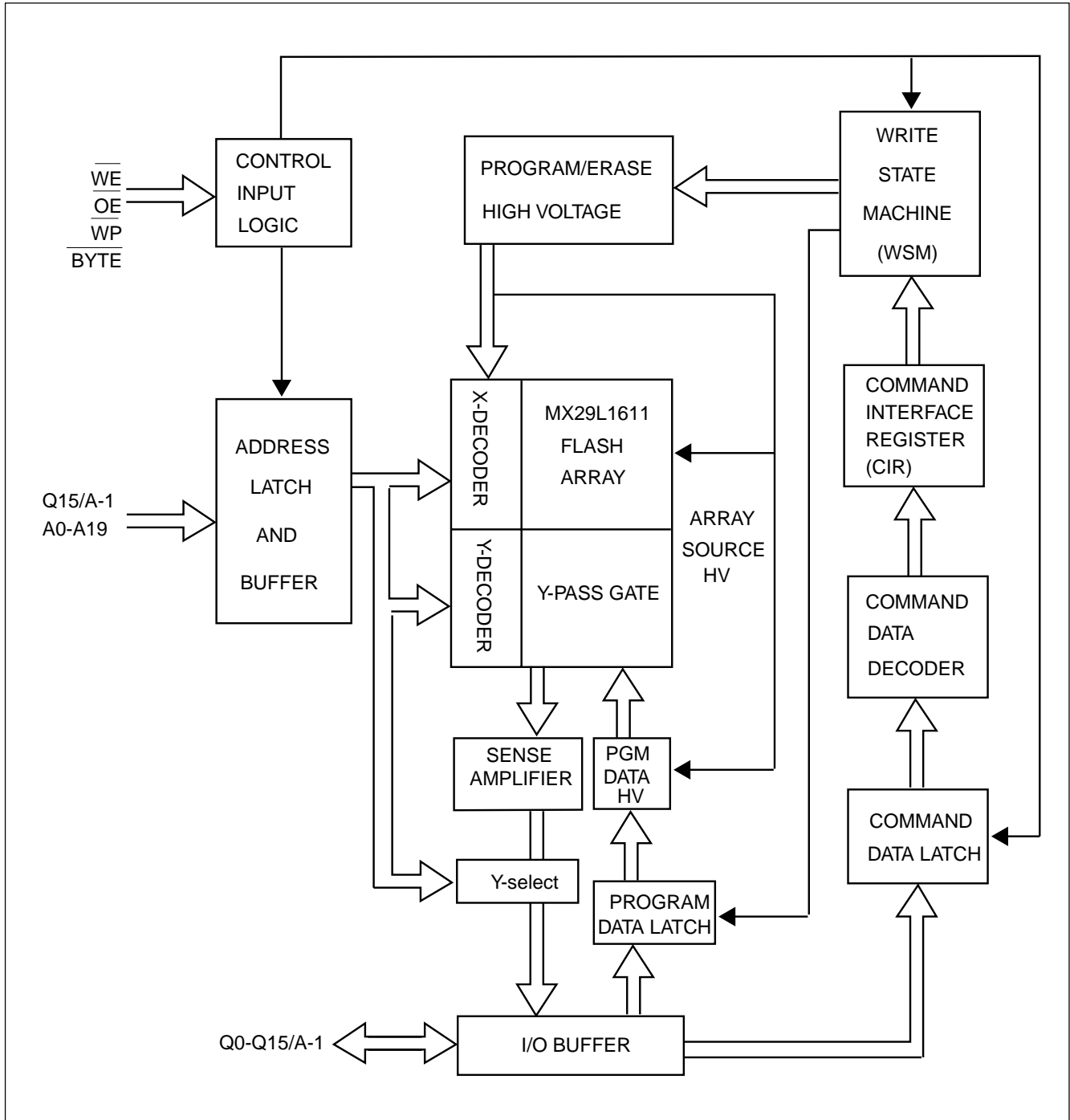
**BLOCK DIAGRAM**

**Table1.PIN DESCRIPTIONS**

<b>SYMBOL</b>	<b>TYPE</b>	<b>NAME AND FUNCTION</b>
A0 - A19	INPUT	ADDRESS INPUTS: for memory addresses. Addresses are internally latched during a write cycle.
Q0 - Q7	INPUT/OUTPUT	LOW-BYTE DATA BUS: Input data and commands during Command Interface Register(CIR) write cycles. Outputs array,status and identifier data in the appropriate read mode. Floated when the chip is de-selected or the outputs are disabled.
Q8 - Q14	INPUT/OUTPUT	HIGH-BYTE DATA BUS: Inputs data during x 16 Data-Write operations. Outputs array, identifier data in the appropriate read mode; not used for status register reads. Floated when the chip is de-selected or the outputs are disabled
Q15/A -1	INPUT/OUTPUT	Selects between high-byte data INPUT/OUTPUT( $\overline{\text{BYTE}} = \text{HIGH}$ ) and LSB ADDRESS( $\overline{\text{BYTE}} = \text{LOW}$ )
$\overline{\text{CE}}$	INPUT	CHIP ENABLE INPUTS: Activate the device's control logic, Input buffers, decoders and sense amplifiers. With $\overline{\text{CE}}$ high, the device is deselected and power consumption reduces to Standby level upon completion of any current program or erase operations. $\overline{\text{CE}}$ must be low to select the device.
$\overline{\text{OE}}$	INPUT	OUTPUT ENABLES: Gates the device's data through the output buffers during a read cycle $\overline{\text{OE}}$ is active low.
$\overline{\text{WE}}$	INPUT	WRITE ENABLE: Controls writes to the Command Interface Register(CIR). $\overline{\text{WE}}$ is active low.
$\overline{\text{WP}}$	INPUT	WRITE PROTECT: Top or Bottom sector can be protected by writing a non-volatile protect-bit for each sector. When $\overline{\text{WP}}$ is high, all sectors can be programmed or erased regardless of the state of the protect-bits.
$\overline{\text{BYTE}}$	INPUT	BYTE ENABLE: $\overline{\text{BYTE}}$ Low places device in x8 mode. All data is then input or output on Q0-7 and Q8-14 float. Address Q15/A-1 selects between the high and low byte. $\overline{\text{BYTE}}$ high places the device in x16 mode, and turns off the Q15/A-1 input buffer. Address A0, then becomes the lowest order address.
VCC		DEVICE POWER SUPPLY(3.0V~3.6V for MX29L1611-75/10/12; 2.7V~3.6V for MX29L1611-90)
GND		GROUND

## BUS OPERATION

Flash memory reads, erases and writes in-system via the local CPU . All bus cycles to or from the flash memory conform to standard microprocessor bus cycles.

**Table 2.1 Bus Operations for Word-Wide Mode (BYTE = VIH)**

Mode	Notes	$\overline{CE}$	$\overline{OE}$	$\overline{WE}$	A0	A1	A9	Q0-Q7	Q8-Q14	Q15/A-1
Read	1	VIL	VIL	VIH	X	X	X	DOUT	DOUT	DOUT
Output Disable	1	VIL	VIH	VIH	X	X	X	High Z	High Z	HighZ
Standby	1	VIH	X	X	X	X	X	High Z	High Z	HighZ
Manufacturer ID	2,4	VIL	VIL	VIH	VIL	VIL	VID	C2H	00H	0B
Device ID	2,4	VIL	VIL	VIH	VIH	VIL	VID	F8H	00H	0B
Write	1,3	VIL	VIH	VIL	X	X	X	DIN	DIN	DIN

**Table2.2 Bus Operations for Byte-Wide Mode (BYTE = VIL)**

Mode	Notes	$\overline{CE}$	$\overline{OE}$	$\overline{WE}$	A0	A1	A9	Q0-Q7	Q8-Q14	Q15/A-1
Read	1	VIL	VIL	VIH	X	X	X	DOUT	HighZ	VIL/VIH
Output Disable	1	VIL	VIH	VIH	X	X	X	High Z	High Z	X
Standby	1	VIH	X	X	X	X	X	High Z	High Z	X
Manufacturer ID	2,4	VIL	VIL	VIH	VIL	VIL	VID	C2H	High Z	VIL
Device ID	2,4	VIL	VIL	VIH	VIH	VIL	VID	F8H	High Z	VIL
Write	1,3	VIL	VIH	VIL	X	X	X	DIN	High Z	VIL/VIH

**NOTES :**

1. X can be VIH or VIL for address or control pins.
2. A0 and A1 at VIL provide manufacturer ID codes. A0 at VIH and A1 at VIL provide device ID codes. A0 at VIL, A1 at VIH and with appropriate sector addresses provide Sector Protect Code.(Refer to Table 4)
3. Commands for different Erase operations, Data program operations or Sector Protect operations can only be successfully completed through proper command sequence.
4. VID = 11.5V- 12.5V.



**WRITE OPERATIONS**

Commands are written to the COMMAND INTERFACE REGISTER (CIR) using standard microprocessor write timings. The CIR serves as the interface between the microprocessor and the internal chip operation. The CIR can decipher Read Array, Read Silicon ID, Erase and Program command. In the event of a read command, the CIR simply points the read path at either the array or the silicon ID, depending on the specific read command given. For a program or erase cycle, the CIR informs the write state machine that a program or erase has been requested. During a program cycle, the write state machine will control the program sequences and the

CIR will only respond to status reads. During a sector/ chip erase cycle, the CIR will respond to status reads and erase suspend. After the write state machine has completed its task, it will allow the CIR to respond to its full command set. The CIR stays at read status register mode until the microprocessor issues another valid command sequence.

Device operations are selected by writing commands into the CIR. Table 3 below defines 16 Mbit flash family command.

**TABLE 3. COMMAND DEFINITIONS**

Command Sequence		Read/Reset	Silicon ID Read	Page/Byte Program	Chip Erase	Sector Erase	Erase Suspend	Erase Resume	Read Status Reg.	Clear Status Reg.
Bus Write Cycles Req'd		4	4	4	6	6	3	3	4	3
First Bus Write Cycle	Addr	5555H	5555H	5555H	5555H	5555H	5555H	5555H	5555H	5555H
	Data	AAH	AAH	AAH	AAH	AAH	AAH	AAH	AAH	AAH
Second Bus Write Cycle	Addr	2AAAH	2AAAH	2AAAH	2AAAH	2AAAH	2AAAH	2AAAH	2AAAH	2AAAH
	Data	55H	55H	55H	55H	55H	55H	55H	55H	55H
Third Bus Write Cycle	Addr	5555H	5555H	5555H	5555H	5555H	5555H	5555H	5555H	5555H
	Data	F0H	90H	A0H	80H	80H	B0H	D0H	70H	50H
Fourth Bus Read/Write Cycle	Addr	RA	00H/01H	PA	5555H	5555H			X	
	Data	RD	C2H/F8H	PD	AAH	AAH			SRD	
Fifth Bus Write Cycle	Addr				2AAAH	2AAAH				
	Data				55H	55H				
Sixth Bus Write Cycle	Addr				5555H	SA				
	Data				10H	30H				

**TABLE 3. COMMAND DEFINITIONS**

Command Sequence		Sector Protection	Sector Unprotect	Verify Sector Protect	Abort
Bus Write Cycles Req'd		6	6	4	3
First Bus Write Cycle	Addr	5555H	5555H	5555H	5555H
	Data	AAH	AAH	AAH	AAH
Second Bus Write Cycle	Addr	2AAAH	2AAAH	2AAAH	2AAAH
	Data	55H	55H	55H	55H
Third Bus Write Cycle	Addr	5555H	5555H	5555H	5555H
	Data	60H	60H	90H	E0H
Fourth Bus Read/Write Cycle	Addr	5555H	5555H	*	
	Data	AAH	AAH	C2H*	
Fifth Bus Write Cycle	Addr	2AAAH	2AAAH		
	Data	55H	55H		
Sixth Bus Write Cycle	Addr	SA**	SA**		
	Data	20H	40H		

**Notes:**

- Address bit A15 -- A19 = X = Don't care for all address commands except for Program Address(PA) and Sector Address(SA). 5555H and 2AAAH address command codes stand for Hex number starting from A0 to A14.
- Bus operations are defined in Table 2.
- RA = Address of the memory location to be read.  
PA = Address of the memory location to be programmed. Addresses are latched on the falling edge of the  $\overline{WE}$  pulse.  
SA = Address of the sector to be erased. The combination of A15 -- A19 will uniquely select any sector.
- RD = Data read from location RA during read operation.  
PD = Data to be programmed at location PA. Data is latched on the rising edge of  $\overline{WE}$ .  
SRD = Data read from status register.
- Only Q0-Q7 command data is taken, Q8-Q15 = Don't care.  
\* Refer to Table 4, Figure 12.  
\*\* Only the top and the bottom sectors have protect-bit feature. SA = (A19,A18,A17,A16,A15) = 00000B or 11111B is valid.

## DEVICE OPERATION

### SILICON ID READ

The Silicon ID Read mode allows the reading out of a binary code from the device and will identify its manufacturer and type. This mode is intended for use by programming equipment for the purpose of automatically matching the device to be programmed with its corresponding programming algorithm. This mode is functional over the entire temperature range of the device.

To activate this mode, the programming equipment must force VID (11.5V~12.5V) on address pin A9. Two identifier bytes may then be sequenced from the device outputs by toggling address A0 from VIL to VIH. All addresses are don't cares except A0 and A1.

The manufacturer and device codes may also be read via the command register, for instances when the MX29L1611 is erased or programmed in a system without access to high voltage on the A9 pin. The command sequence is illustrated in Table 3.

Byte 0 (A0=VIL) represents the manufacturer's code (MXIC=C2H) and byte 1 (A0=VIH) the device identifier code (MX29L1611=F8H).

To terminate the operation, it is necessary to write the read/reset command sequence into the CIR.

**Table 4. MX29L1611 Silicon ID Codes and Verify Sector Protect Code**

Type	A <sub>19</sub>	A <sub>18</sub>	A <sub>17</sub>	A <sub>16</sub>	A <sub>15</sub>	A <sub>1</sub>	A <sub>0</sub>	Code(HEX)	DQ <sub>7</sub>	DQ <sub>6</sub>	DQ <sub>5</sub>	DQ <sub>4</sub>	DQ <sub>3</sub>	DQ <sub>2</sub>	DQ <sub>1</sub>	DQ <sub>0</sub>
Manufacturer Code	X	X	X	X	X	VIL	VIL	C2H*	1	1	0	0	0	0	1	0
MX29L1611 Device Code	X	X	X	X	X	VIL	VIH	F8H*	1	1	1	1	1	0	0	0
Verify Sector Protect	Sector Address***					VIH	VIL	C2H**	1	1	0	0	0	0	1	0

\* MX29L1611 Manufacturer Code = C2H, Device Code = F8H when  $\overline{\text{BYTE}}$  = VIL

MX29L1611 Manufacturer Code = 00C2H, Device Code = 00F8H when  $\overline{\text{BYTE}}$  = VIH

\*\* Outputs C2H at protected sector address, 00H at unprotected sector address.

\*\*\*Only the top and the bottom sectors have protect-bit feature. Sector address = (A19, A18,A17,A16,A15) = 00000B or 11111B



## READ/RESET COMMAND

The read or reset operation is initiated by writing the read/reset command sequence into the command register. Microprocessor read cycles retrieve array data from the memory. The device remains enabled for reads until the CIR contents are altered by a valid command sequence.

The device will automatically power-up in the read/reset state. In this case, a command sequence is not required for "read operation". Standard microprocessor read cycles will retrieve array data. This default value ensures that no spurious alteration of the memory content occurs during the power transition. Refer to the AC Read Characteristics and Waveforms for the specific timing parameters.

The MX29L1611 is accessed like an EPROM. When  $\overline{CE}$  and  $\overline{OE}$  are low and  $\overline{WE}$  is high the data stored at the memory location determined by the address pins is asserted on the outputs. The outputs are put in the high impedance state whenever  $\overline{CE}$  or  $\overline{OE}$  is high. This dual line control gives designers flexibility in preventing bus contention.

Note that the read/reset command is not valid when program or erase is in progress.

## PAGE READ

The MX29L1611 offers "fast page mode read" function. The users can take the access time advantage if keeping  $\overline{CE}$ ,  $\overline{OE}$  at low and the same page address (A3~A19 unchanged). Please refer to Figure 5-2 for detailed timing waveform. The system performance could be enhanced by initiating 1 normal read and 7 fast page reads(for word mode A0~A2) or 15 fast page reads(for byte mode altering A-1~A2).

## PAGE PROGRAM

To initiate Page program mode, a three-cycle command sequence is required. There are two "unlock" write cycles. These are followed by writing the page program command-A0H.

Any attempt to write to the device without the three-cycle command sequence will not start the internal Write State Machine(WSM), no data will be written to the device.

After three-cycle command sequence is given, a byte(word) load is performed by applying a low pulse on the  $\overline{WE}$  or  $\overline{CE}$  input with  $\overline{CE}$  or  $\overline{WE}$  low (respectively) and  $\overline{OE}$  high. The address is latched on the falling edge of  $\overline{CE}$  or  $\overline{WE}$ , whichever occurs last. The data is latched by the first rising edge of  $\overline{CE}$  or  $\overline{WE}$ . Maximum of 128 bytes of data may be loaded into each page by the same procedure as outlined in the page program section below.

## BYTE-WIDE LOAD/WORD-WIDE LOAD

Byte(word) loads are used to enter the 128 bytes(64 words) of a page to be programmed or the software codes for data protection. A byte load(word load) is performed by applying a low pulse on the  $\overline{WE}$  or  $\overline{CE}$  input with  $\overline{CE}$  or  $\overline{WE}$  low (respectively) and  $\overline{OE}$  high. The address is latched on the falling edge of  $\overline{CE}$  or  $\overline{WE}$ , whichever occurs last. The data is latched by the first rising edge of  $\overline{CE}$  or  $\overline{WE}$ .

Either byte-wide load or word-wide load is determined( $\overline{Byte} = \overline{VIL}$  or  $\overline{VIH}$  is latched) on the falling edge of the  $\overline{WE}$  (or  $\overline{CE}$ ) during the 3rd command write cycle.

## PROGRAM

Any page to be programmed should have the page in the erased state first, i.e. performing sector erase is suggested before page programming can be performed.

The device is programmed on a page basis. If a byte(word) of data within a page is to be changed, data for the entire page can be loaded into the device. Any byte(word) that is not loaded during the programming of its page will be still in the erased state (i.e. FFH). Once the bytes of a page are loaded into the device, they are simultaneously programmed during the internal programming period. After the first data byte(word) has been loaded into the device, successive bytes(words) are entered in the same manner. Each new byte(word) to be programmed must have its high to low transition on  $\overline{WE}$  (or  $\overline{CE}$ ) within 30us of the low to high transition of  $\overline{WE}$  (or  $\overline{CE}$ ) of the preceding byte(word). A6 to A19 specify the page address, i.e., the device is page-aligned on 128 bytes(64 words)boundary. The page address must be valid during each high to low transition of  $\overline{WE}$  or  $\overline{CE}$ . A-1 to A5 specify the byte address within the page, A0 to A5 specify the word address within the page. The

byte(word) may be loaded in any order; sequential loading is not required. If a high to low transition of  $\overline{CE}$  or  $\overline{WE}$  is not detected within 100us of the last low to high transition, the load period will end and the internal programming period will start. The Auto page program terminates when status on DQ7 is '1' at which time the device stays at read status register mode until the CIR contents are altered by a valid command sequence. (Refer to table 3,6 and Figure 1,7,8)

## CHIP ERASE

Chip erase is a six-bus cycle operation. There are two "unlock" write cycles. These are followed by writing the "set-up" command-80H. Two more "unlock" write cycles are then followed by the chip erase command-10H.

Chip erase does not require the user to program the device prior to erase.

The automatic erase begins on the rising edge of the last  $\overline{WE}$  pulse in the command sequence and terminates when the status on DQ7 is "1" at which time the device stays at read status register mode. The device remains enabled for read status register mode until the CIR contents are altered by a valid command sequence. (Refer to table 3,6 and Figure 2,7,9)

**Table 5. MX29L1611 Sector Address Table**

(Byte-Wide Mode)

	A19	A18	A17	A16	A15	Address Range[A19, -1]
SA0	0	0	0	0	0	000000H--00FFFFH
SA1	0	0	0	0	1	010000H--01FFFFH
SA2	0	0	0	1	0	020000H--02FFFFH
SA3	0	0	0	1	1	030000H--03FFFFH
SA4	0	0	1	0	0	040000H--04FFFFH
...	...	...	...	...	...	.....
SA31	1	1	1	1	1	1F0000H--1FFFFFFH

## SECTOR ERASE

Sector erase is a six-bus cycle operation. There are two "unlock" write cycles. These are followed by writing the set-up command-80H. Two more "unlock" write cycles are then followed by the sector erase command-30H. The sector address is latched on the falling edge of  $\overline{WE}$ , while the command (data) is latched on the rising edge of  $\overline{WE}$ .

Sector erase does not require the user to program the device prior to erase. The system is not required to provide any controls or timings during these operations.

The automatic sector erase begins on the rising edge of the last  $\overline{WE}$  pulse in the command sequence and terminates when the status on DQ7 is "1" at which time the device stays at read status register mode. The device remains enabled for read status register mode until the CIR contents are altered by a valid command sequence. (Refer to table 3,6 and Figure 3,4,7,9)

## ERASE SUSPEND

This command only has meaning while the the WSM is executing SECTOR or CHIP erase operation, and therefore will only be responded to during SECTOR or CHIP erase operation. After this command has been executed, the CIR will initiate the WSM to suspend erase operations, and then return to Read Status Register mode. The WSM will set the DQ6 bit to a "1". Once the WSM has reached the Suspend state, the WSM will set the DQ7 bit to a "1", At this time, WSM allows the CIR to respond to the Read Array, Read Status Register, Abort and Erase Resume commands only. In this mode, the CIR will not respond to any other commands. The WSM will continue to run, idling in the SUSPEND state, regardless of the state of all input control pins.

## ERASE RESUME

This command will cause the CIR to clear the suspend state and set the DQ6 to a '0', but only if an Erase Suspend command was previously issued. Erase Resume will not have any effect in all other conditions.

## READ STATUS REGISTER

The MXIC's 16 Mbit flash family contains a status register which may be read to determine when a program or erase operation is complete, and whether that operation completed successfully. The status register may be read at any time by writing the Read Status command to the CIR. After writing this command, all subsequent read operations output data from the status register until another valid command sequence is written to the CIR. A Read Array command must be written to the CIR to return to the Read Array mode.

The status register bits are output on DQ3 - DQ7 (table 6) whether the device is in the byte-wide (x8) or word-wide (x16) mode for the MX29L1611. In the word-wide mode the upper byte, DQ(8:15) is set to 00H during a Read Status command. In the byte-wide mode, DQ(8:14) are tri-stated and DQ15/A-1 retains the low order address function.

It should be noted that the contents of the status register are latched on the falling edge of  $\overline{OE}$  or  $\overline{CE}$  whichever occurs last in the read cycle. This prevents possible bus errors which might occur if the contents of the status register change while reading the status register.  $\overline{CE}$  or  $\overline{OE}$  must be toggled with each subsequent status read, or the completion of a program or erase operation will not be evident.

The Status Register is the interface between the microprocessor and the Write State Machine (WSM). When the WSM is active, this register will indicate the status of the WSM, and will also hold the bits indicating whether or not the WSM was successful in performing the desired operation. The WSM sets status bits four through seven and clears bits six and seven, but cannot clear status bits four and five. If Erase fail or Program fail status bit is detected, the Status Register is not cleared until the Clear Status Register command is written. The MX29L1611 automatically outputs Status Register data when read after Chip Erase, Sector Erase, Page Program or Read Status Command write cycle. The default state of the Status Register after powerup and return from deep power-down mode is (DQ7, DQ6, DQ5, DQ4) = 1000B. DQ3 = 0 or 1 depends on sector-protect status, can not be changed by Clear Status Register Command or Write State Machine.

## CLEAR STATUS REGISTER

The Erase fail status bit (DQ5) and Program fail status bit (DQ4) are set by the write state machine, and can only be reset by the system software. These bits can indicate various failure conditions (see Table 6). By allowing the system software to control the resetting of these bits, several operations may be performed (such as cumulatively programming several pages or erasing multiple blocks in sequence). The status register may then be read to determine if an error occurred during that programming or erasure series. This adds flexibility to the way the device may be programmed or erased. Additionally, once the program (erase) fail bit happens, the program (erase) operation can not be performed further. The program (erase) fail bit must be reset by system software before further page program or sector (chip) erase are attempted. To clear the status register, the Clear Status Register command is written to the CIR. Then, any other command may be issued to the CIR. Note again that before a read cycle can be initiated, a Read command must be written to the CIR to specify whether the read data is to come from the Array, Status Register or Silicon ID.

**TABLE 6. MX29L1611 STATUS REGISTER**

	STATUS	NOTES	DQ7	DQ6	DQ5	DQ4	DQ3
<b>IN PROGRESS</b>	PROGRAM	1,2, 6	0	0	0	0	0/1
	ERASE	1,3, 6	0	0	0	0	0/1
	SUSPEND (NOT COMPLETE)	1,4, 6	0	1	0	0	0/1
	(COMPLETE)		1	1	0	0	0/1
<b>COMPLETE</b>	PROGRAM	1,2, 6	1	0	0	0	0/1
	ERASE	1,3, 6	1	0	0	0	0/1
<b>FAIL</b>	PROGRAM	1,5, 6	1	0	0	1	0/1
	ERASE	1,5, 6	1	0	1	0	0/1
<b>AFTER CLEARING STATUS REGISTER</b>		6	1	0	0	0	0/1

**NOTES:**

1. DQ7 : WRITE STATE MACHINE STATUS

1 = READY, 0 = BUSY

DQ6 : ERASE SUSPEND STATUS

1 = SUSPEND, 0 = NO SUSPEND

DQ5 : ERASE FAIL STATUS

1 = FAIL IN ERASE, 0 = SUCCESSFUL ERASE

DQ4 : PROGRAM FAIL STATUS

1 = FAIL IN PROGRAM, 0 = SUCCESSFUL PROGRAM

DQ3 : SECTOR-PROTECT STATUS

1 = SECTOR 0 OR/AND 15 PROTECTED

0 = NONE OF SECTOR PROTECTED

DQ2 - 0 = RESERVED FOR FUTURE ENHANCEMENTS.

These bits are reserved for future use ; mask them out when polling the Status Register.

2. PROGRAM STATUS is for the status during Page Programming or Sector Unprotect mode.

3. ERASE STATUS is for the status during Sector/Chip Erase or Sector Protection mode.

4. SUSPEND STATUS is for both Sector and Chip Erase mode .

5. FAIL STATUS bit(DQ4 or DQ5) is provided during Page Program or Sector/Chip Erase modes respectively.

6. DQ3 = 0 or1 depends on Sector-Protect Status.

## HARDWARE SECTOR PROTECTION

The MX29L1611 features sector protection. This feature will disable both program and erase operations in either the top or the bottom sector (0 or 31). The sector protection feature is enabled using system software by the user (Refer to table 3). The device is shipped with both sectors unprotected. Alternatively, MXIC may protect sectors in the factory prior to shipping the device.

## SECTOR PROTECTION

To activate this mode, a six-bus cycle operation is required. There are two 'unlock' write cycles. These are followed by writing the 'set-up' command. Two more 'unlock' write cycles are then followed by the Lock Sector command - 20H. Sector address is latched on the falling edge of CE or WE of the sixth cycle of the command sequence. The automatic Lock operation begins on the rising edge of the last WE pulse in the command sequence and terminates when the Status on DQ7 is '1' at which time the device stays at the read status register mode.

The device remains enabled for read status register mode until the CIR contents are altered by a valid command sequence (Refer to table 3,6 and Figure 10,12).

## VERIFY SECTOR PROTECT

To verify the Protect status of the Top and the Bottom sector, operation is initiated by writing Silicon ID read command into the command register. Following the command write, a read cycle from address XXX0H retrieves the Manufacturer code of C2H. A read cycle from XXX1H returns the Device code F8H. A read cycle from appropriate address returns information as to which sectors are protected. To terminate the operation, it is necessary to write the read/reset command sequence into the CIR.

(Refer to table 3,4 and Figure 12)

A few retries are required if Protect status can not be verified successfully after each operation.

## SECTOR UNPROTECT

It is also possible to unprotect the sector, same as the first five write command cycles in activating sector protection mode followed by the Unprotect Sector command -40H, the automatic Unprotect operation begins on the rising edge of the last WE pulse in the command sequence and terminates when the Status on DQ7 is '1' at which time the device stays at the read status register mode. (Refer to table 3,6 and Figure 11,12)

The device remains enabled for read status register mode until the CIR contents are altered by a valid command sequence.

Either Protect or Unprotect sector mode is accomplished by keeping WP high, i.e. protect-bit status can only be changed with a valid command sequence and WP at high. When WP is high, all sectors can be programmed or erased regardless of the state of the protect-bits. Protect-bit status will not be changed during chip/sector erase operations. With WP at VIL, only unprotected sectors can be programmed or erased.

## ABORT MODE

To activate Abort mode, a three-bus cycle operation is required. The E0H command (Refer to table 3) only stops Page program or Sector /Chip erase operation currently in progress and puts the device in Abort mode. So the program or erase operation will not be completed. Since the data in some page/sectors is no longer valid due to an incomplete program or erase operation, the program fail (DQ4) or erase fail (DQ5) bit will be set.

A read array command MUST be written to bring the device out of the abort state without incurring any wake up latency. Note that once device is brought out, Clear status register mode is required before a program or erase operation can be executed.

## **DATA PROTECTION**

The MX29L1611 is designed to offer protection against accidental erasure or programming caused by spurious system level signals that may exist during power transitions. During power up the device automatically resets the internal state machine in the Read Array mode. Also, with its control register architecture, alteration of the memory contents only occurs after successful completion of specific multi-bus cycle command sequences.

The device also incorporates several features to prevent inadvertent write cycles resulting from VCC power-up and power-down transitions or system noise.

## **LOW VCC WRITE INHIBIT**

To avoid initiation of a write cycle during VCC power-up and power-down, a write cycle is locked out for VCC less than VLKO (typically 1.8V). If  $VCC < VLKO$ , the command register is disabled and all internal program/erase circuits are disabled. Under this condition the device will reset to the read mode. Subsequent writes will be ignored until the VCC level is greater than VLKO. It is the user's responsibility to ensure that the control pins are logically correct to prevent unintentional write when VCC is above VLKO.

## **WRITE PULSE "GLITCH" PROTECTION**

Noise pulses of less than 10ns (typical) on  $\overline{CE}$  or  $\overline{WE}$  will not initiate a write cycle.

## **LOGICAL INHIBIT**

Writing is inhibited by holding any one of  $\overline{OE} = VIL$ ,  $\overline{CE} = VIH$  or  $\overline{WE} = VIH$ . To initiate a write cycle  $\overline{CE}$  and  $\overline{WE}$  must be a logical zero while  $\overline{OE}$  is a logical one.

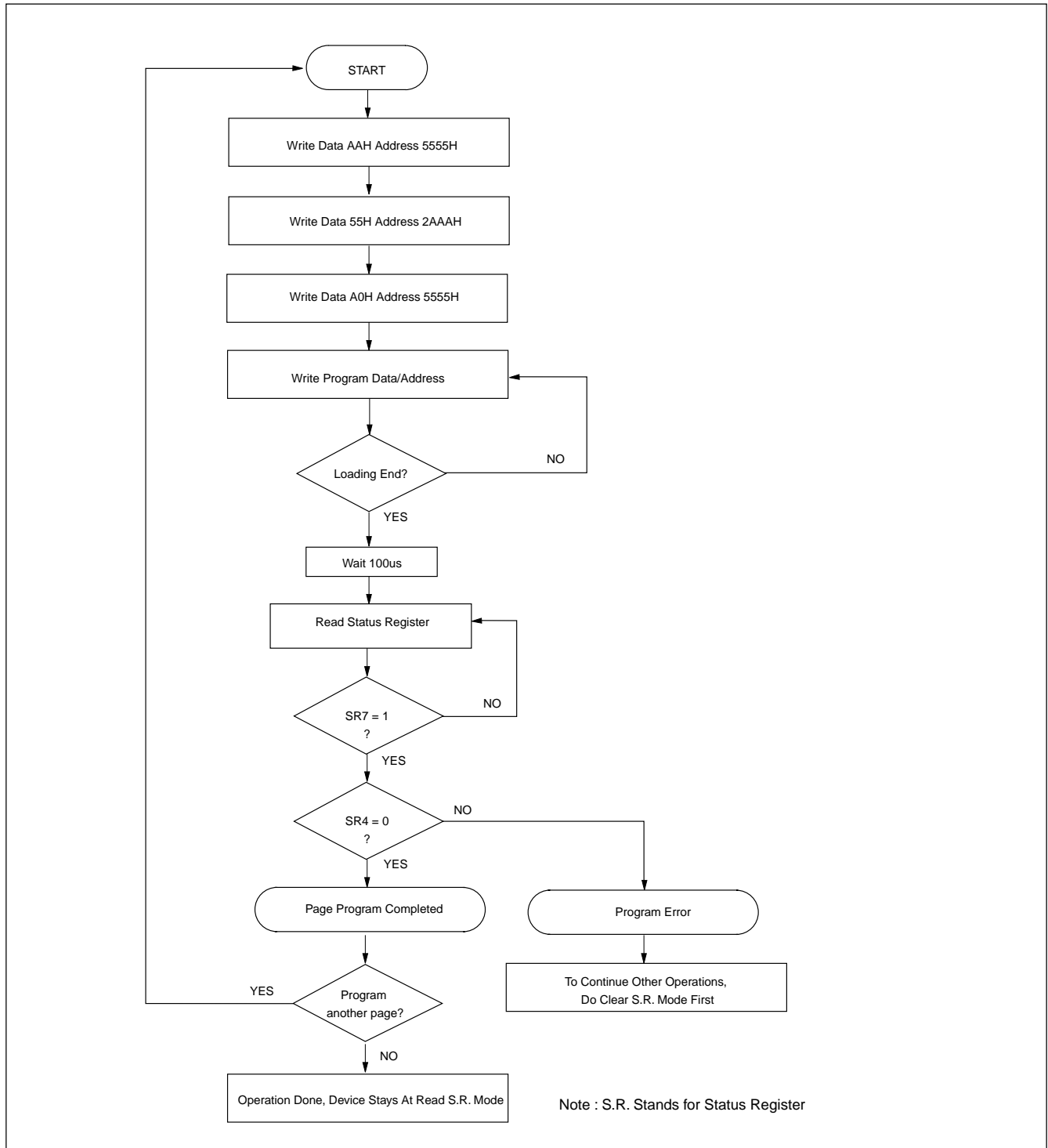
**Figure 1. AUTOMATIC PAGE PROGRAM FLOW CHART**

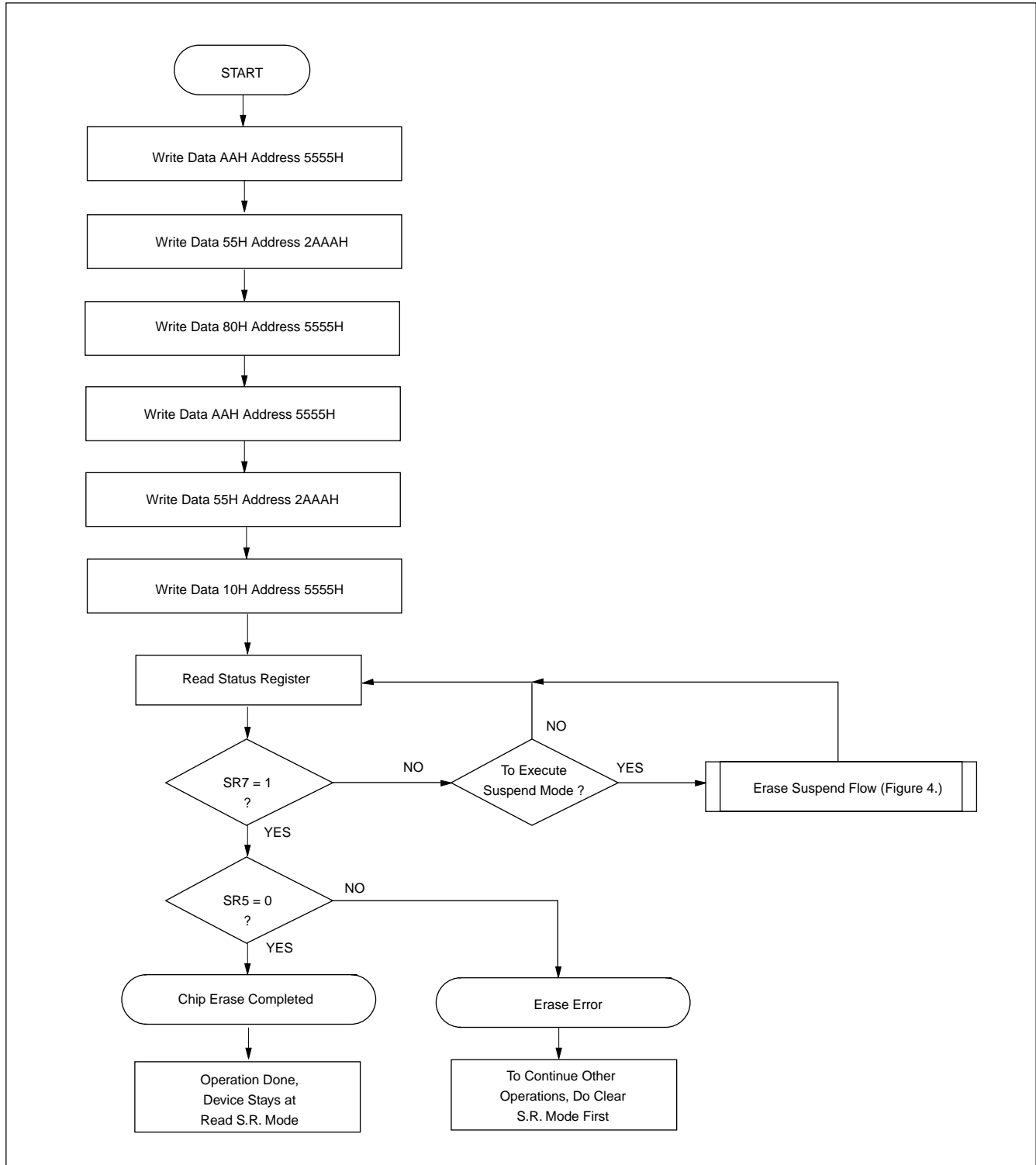
**Figure 2. AUTOMATIC CHIP ERASE FLOW CHART**

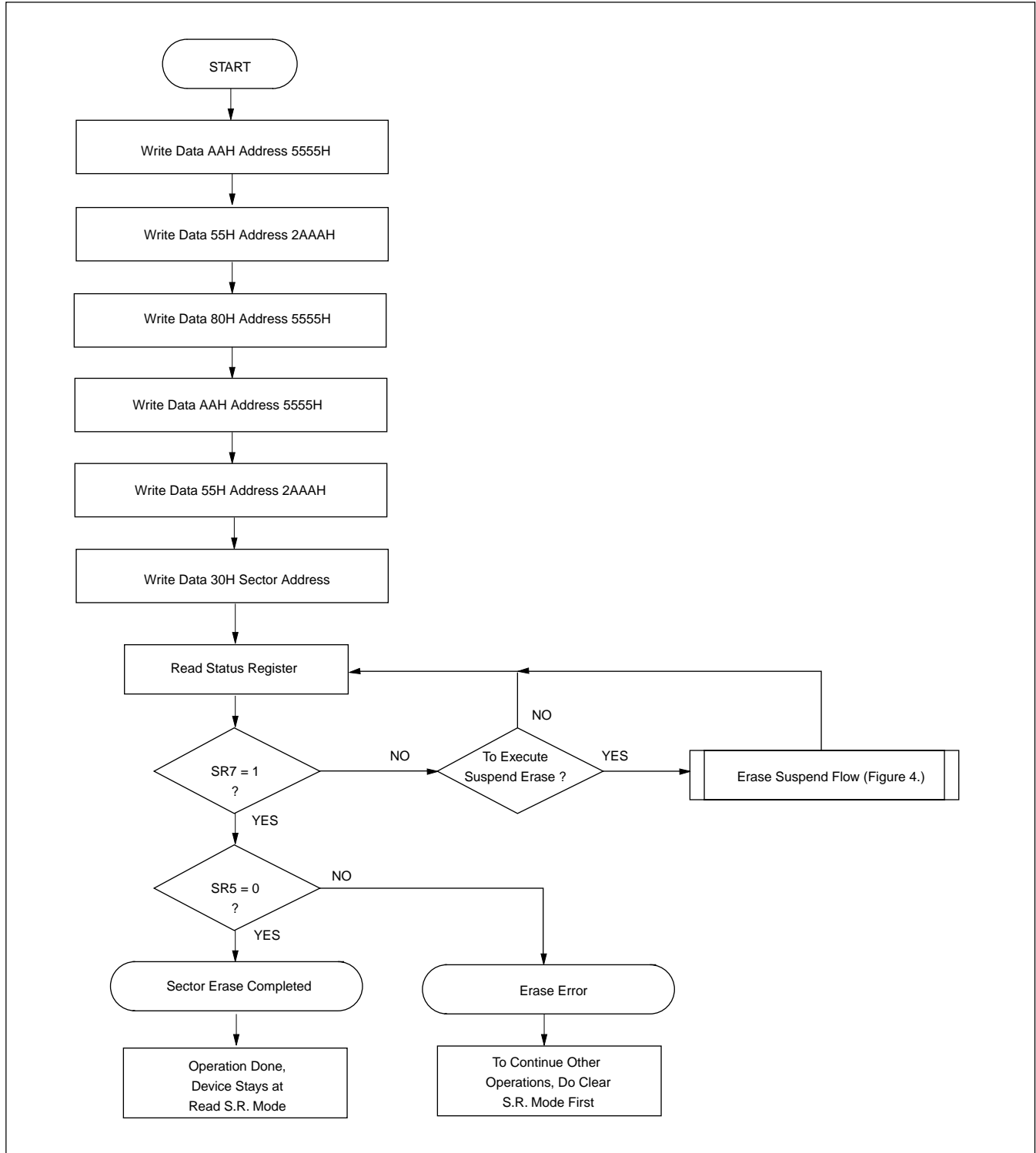

**Figure 3. AUTOMATIC SECTOR ERASE FLOW CHART**

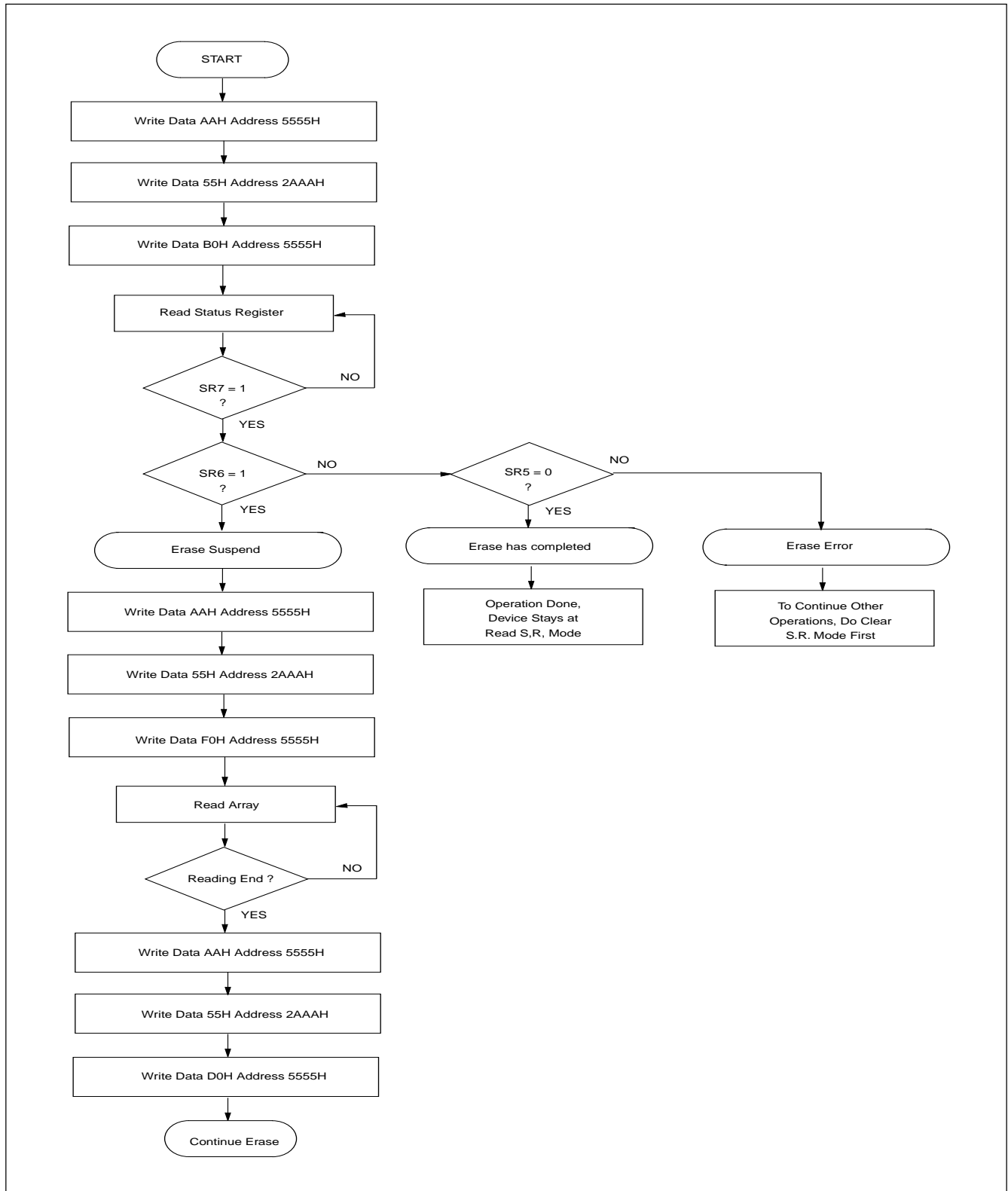
**Figure 4. ERASE SUSPEND/ERASE RESUME FLOW CHART**

## ELECTRICAL SPECIFICATIONS

### ABSOLUTE MAXIMUM RATINGS

RATING	VALUE
Ambient Operating Temperature	0°C to 70°C
Storage Temperature	-65°C to 125°C
Applied Input Voltage	-0.5V to V <sub>cc</sub> +0.5V
Applied Output Voltage	-0.5V to V <sub>cc</sub> +0.6V
VCC to Ground Potential	-0.5V to 4.0V
A9	-0.5V to 12.5V

#### NOTICE:

Stresses greater than those listed under ABSOLUTE MAXIMUM RATINGS may cause permanent damage to the device. This is stress rating only and functional operational sections of this specification is not implied. Exposure to absolute maximum rating conditions for extended period may affect reliability.

#### NOTICE:

Specifications contained within the following tables are subject to change.

### CAPACITANCE TA = 25°C, f = 1.0 MHz

SYMBOL	PARAMETER	MIN.	TYP.	MAX.	UNIT	CONDITIONS
CIN	Input Capacitance			14	pF	VIN = 0V
COUT	Output Capacitance			16	pF	VOUT = 0V

### SWITCHING TEST CIRCUITS

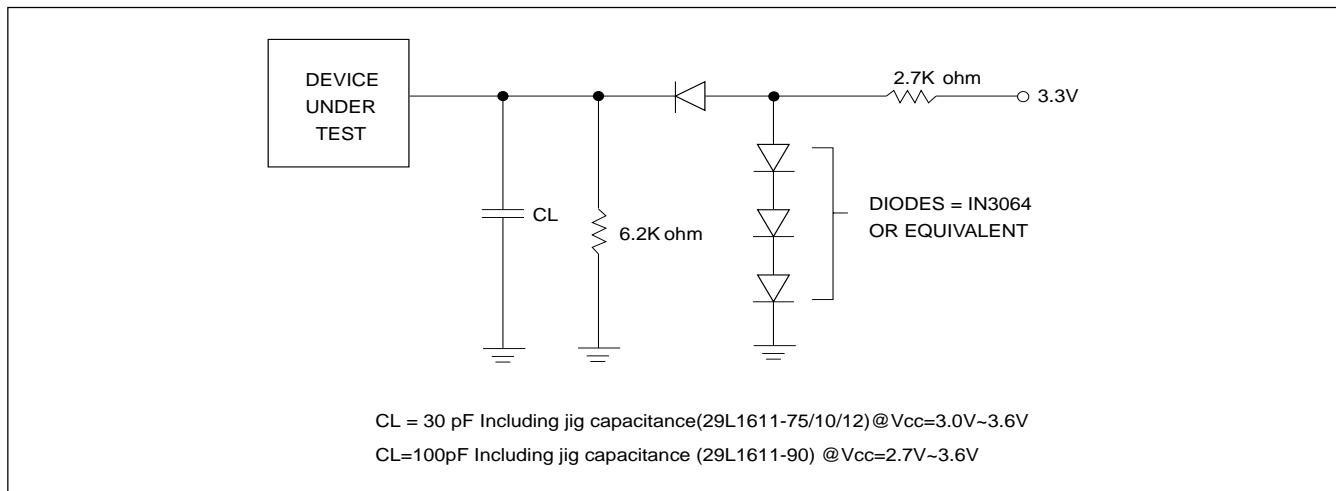

### SWITCHING TEST WAVEFORMS

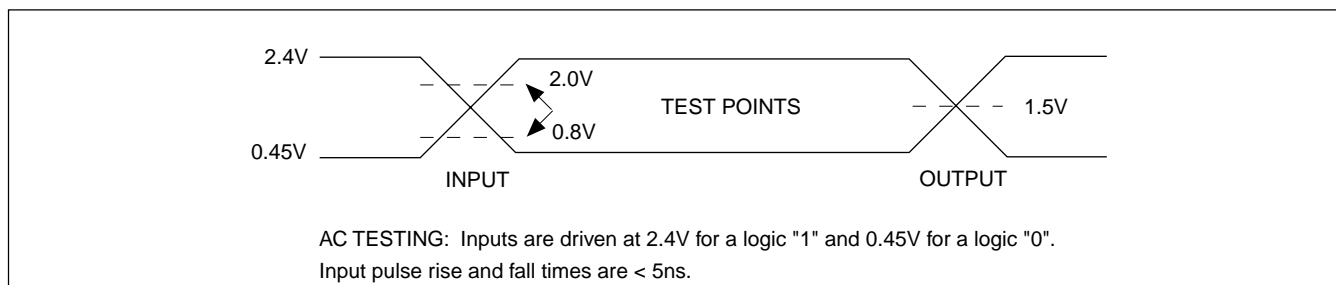

**5.1 DC CHARACTERISTICS V<sub>CC</sub> = 3.0V ~ 3.6V**

SYMBOL	PARAMETER	NOTES	MIN.	TYP.	MAX.	UNITS	TEST CONDITIONS
IIL	Input Load Current	1			±1	uA	V <sub>CC</sub> = V <sub>CC</sub> Max V <sub>IN</sub> = V <sub>CC</sub> or GND
ILO	Output Leakage Current	1			±10	uA	V <sub>CC</sub> = V <sub>CC</sub> Max V <sub>IN</sub> = V <sub>CC</sub> or GND
ISB1	V <sub>CC</sub> Standby Current(CMOS)	1		20	50	uA	V <sub>CC</sub> = V <sub>CC</sub> Max $\overline{CE}$ = V <sub>CC</sub> ± 0.2V
ISB2	V <sub>CC</sub> Standby Current(TTL)			1	2	mA	V <sub>CC</sub> = V <sub>CC</sub> Max $\overline{CE}$ = V <sub>IH</sub>
ICC1	V <sub>CC</sub> Read Current	1		50	80	mA	V <sub>CC</sub> = V <sub>CC</sub> Max f = 10MHz, IO <sub>UT</sub> = 0 mA
ICC2	V <sub>CC</sub> Erase Suspend Current	1,2			5	mA	$\overline{CE}$ = V <sub>IH</sub> Sector Erase Suspended
ICC3	V <sub>CC</sub> Program Current	1		15	30	mA	Program in Progress
ICC4	V <sub>CC</sub> Erase Current	1		15	30	mA	Erase in Progress
VIL	Input Low Voltage	3	-0.3		0.6	V	
VIH	Input High Voltage	4	0.7xV <sub>CC</sub>		V <sub>CC</sub> +0.3	V	
VOL	Output Low Voltage				0.45	V	I <sub>OL</sub> = 2.1mA, V <sub>CC</sub> = V <sub>CC</sub> Min
VOH	Output High Voltage		2.4			V	I <sub>OH</sub> = -100uA, V <sub>CC</sub> = V <sub>CC</sub> Min

**NOTES:**

- All currents are in RMS unless otherwise noted. Typical values at V<sub>CC</sub> = 3.3V, T = 25°C. These currents are valid for all product versions (package and speeds).
- ICC2 is specified with the device de-selected. If the device is read while in erase suspend mode, current draw is the sum of ICC2 and ICC1.
- VIL min. = -1.0V for pulse width ≤ 50ns.  
VIL min. = -2.0V for pulse width ≤ 20ns.
- VIH max. = V<sub>CC</sub> + 1.5V for pulse width ≤ 20ns. If VIH is over the specified maximum value, read operation cannot be guaranteed.

**AC CHARACTERISTICS -- READ OPERATIONS**

SYMBOL	DESCRIPTIONS	29L1611-75		29L1611-90		UNIT	CONDITIONS
		MIN.	MAX.	MIN.	MAX.		
tACC	Address to Output Delay		75		90	ns	$\overline{CE}=\overline{OE}=VIL$
tPA	Page Mode Access Time		30		35	ns	$\overline{CE}=\overline{OE}=VIL$
tCE	$\overline{CE}$ to Output Delay		75		90	ns	$\overline{OE}=VIL$
tOE	$\overline{OE}$ to Output Delay		30		35	ns	$\overline{CE}=VIL$
tDF	$\overline{OE}$ High to Output Delay	0	20	0	20	ns	$\overline{CE}=VIL$
tOH	Address to Output hold	0		0		ns	$\overline{CE}=\overline{OE}=VIL$
tBACC	$\overline{BYTE}$ to Output Delay		75		90	ns	$\overline{CE}=\overline{OE}=VIL$
tBHZ	$\overline{BYTE}$ Low to Output in High Z		20		20	ns	$\overline{CE}=VIL$

SYMBOL	DESCRIPTIONS	29L1611-10		29L1611-12		UNIT	CONDITIONS
		MIN.	MAX.	MIN.	MAX.		
tACC	Address to Output Delay		100		120	ns	$\overline{CE}=\overline{OE}=VIL$
tPA	Page Mode Access Time		30		40	ns	$\overline{CE}=\overline{OE}=VIL$
tCE	$\overline{CE}$ to Output Delay		100		120	ns	$\overline{OE}=VIL$
tOE	$\overline{OE}$ to Output Delay		30		30	ns	$\overline{CE}=VIL$
tDF	$\overline{OE}$ High to Output Delay	0	20	0	20	ns	$\overline{CE}=VIL$
tOH	Address to Output hold	0		0		ns	$\overline{CE}=\overline{OE}=VIL$
tBACC	$\overline{BYTE}$ to Output Delay		100		120	ns	$\overline{CE}=\overline{OE}=VIL$
tBHZ	$\overline{BYTE}$ Low to Output in High Z		20		20	ns	$\overline{CE}=VIL$

NOTE: In the voltage range 3.0~3.6V, 29L1611-90 achieves tPA=30ns or better.

**TEST CONDITIONS:**

- Input pulse levels: 0.45V/2.4V
- Input rise and fall times: 5ns
- Output load:

Speed options	output load (Including scope and jig)
29L1611-75	1TTL gate + 30pF
29L1611-90/10/12	1TTL gate + 100pF

- Reference levels for measuring timing: 1.5V

NOTE:

1. tDF is defined as the time at which the output achieves the open circuit condition and data is no longer driven.

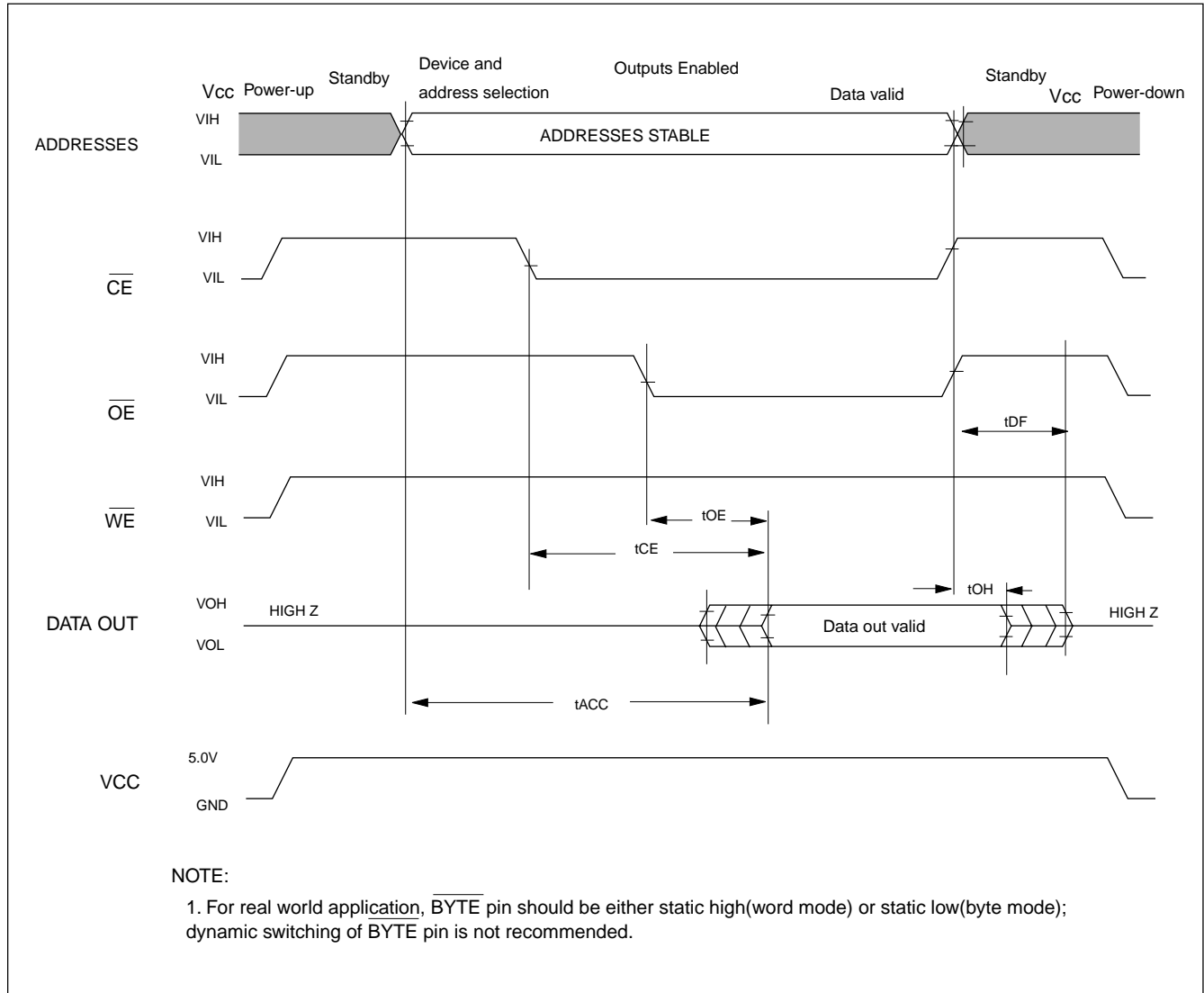
**Figure 5-1. NORMAL READ TIMING WAVEFORMS**

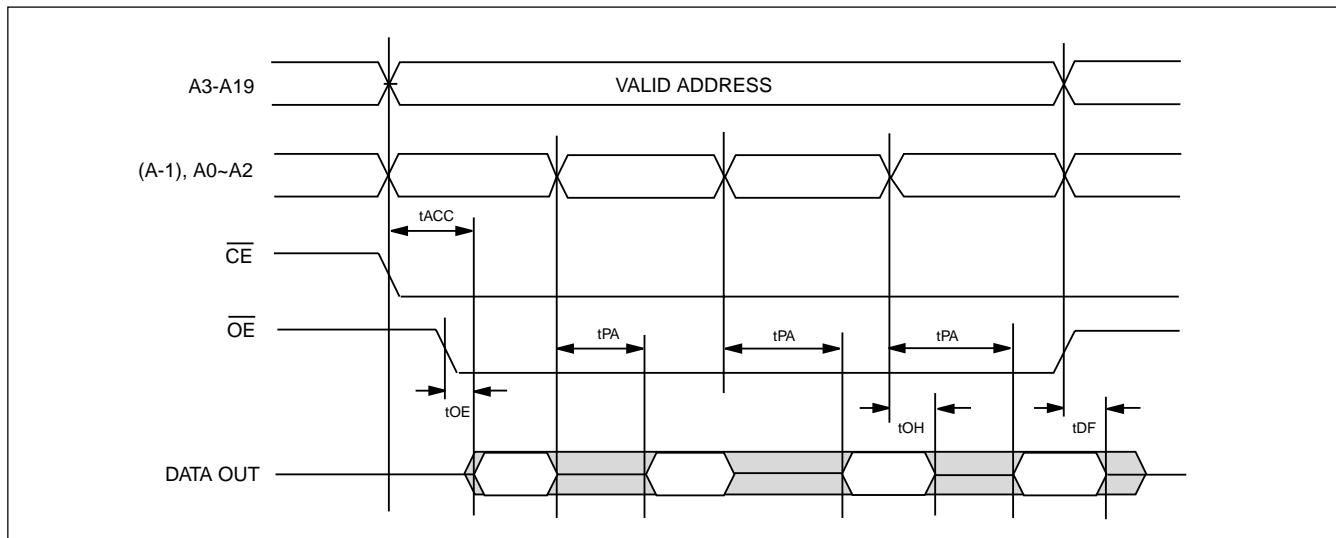
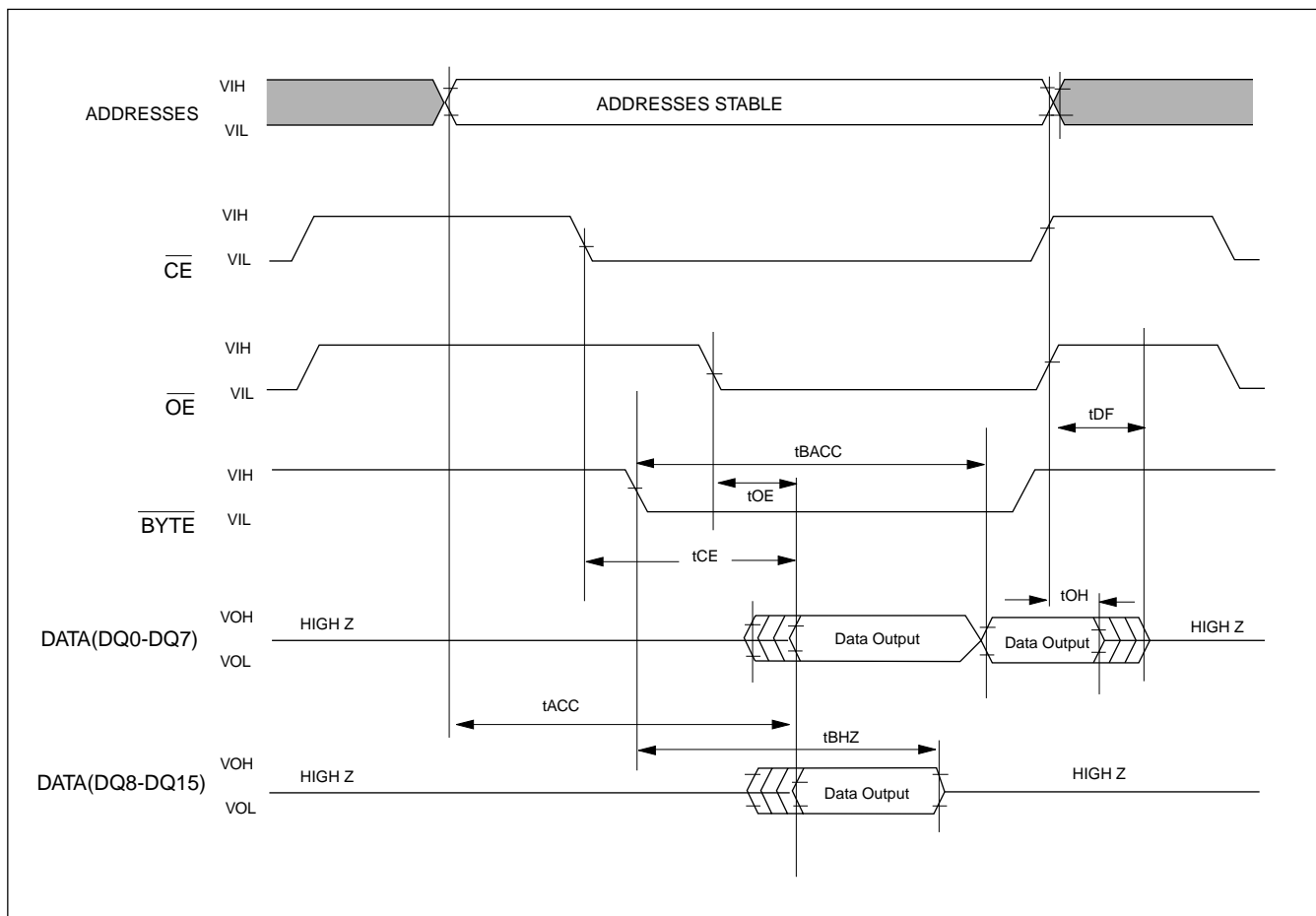
**Figure 5-2. PAGE READ TIMING WAVEFORMS**

**Figure 6. BYTE TIMING WAVEFORMS**

**AC CHARACTERISTICS -- WRITE/ERASE/PROGRAM OPERATIONS**

SYMBOL	DESCRIPTION	29L1611-75		29L1611-90		UNIT
		MIN.	MAX.	MIN.	MAX.	
tWC	Write Cycle Time	75		90		ns
tAS	Address Setup Time	0		0		ns
tAH	Address Hold Time	45		45		ns
tDS	Data Setup Time	35		45		ns
tDH	Data Hold Time	10		10		ns
tOES	Output Enable Setup Time	0		0		ns
tCES	$\overline{\text{CE}}$ Setup Time	0		0		ns
tGHWL	Read Recover Time Before Write	0		0		
tCS	$\overline{\text{CE}}$ Setup Time	0		0		ns
tCH	$\overline{\text{CE}}$ Hold Time	0		0		ns
tWP	Write Pulse Width	35		35		ns
tWPH	Write Pulse Width High	30		30		ns
tBALC	Byte(Word) Address Load Cycle	0.3	30	0.3	30	us
tBAL	Byte(Word) Address Load Time	100		100		us
tSRA	Status Register Access Time		75		90	ns
tCESR	$\overline{\text{CE}}$ Setup before S.R. Read	100		100		ns
tVCS	VCC Setup Time	2		2		us



**AC CHARACTERISTICS -- WRITE/ERASE/PROGRAM OPERATIONS**

SYMBOL	DESCRIPTION	29L1611-10		29L1611-12		UNIT
		MIN.	MAX.	MIN.	MAX.	
tWC	Write Cycle Time	100		120		ns
tAS	Address Setup Time	0		0		ns
tAH	Address Hold Time	60		60		ns
tDS	Data Setup Time	50		50		ns
tDH	Data Hold Time	10		10		ns
tOES	Output Enable Setup Time	0		0		ns
tCES	$\overline{CE}$ Setup Time	0		0		ns
tGHWL	Read Recover Time Before Write	0		0		
tCS	$\overline{CE}$ Setup Time	0		0		ns
tCH	$\overline{CE}$ Hold Time	0		0		ns
tWP	Write Pulse Width	60		60		ns
tWPH	Write Pulse Width High	40		40		ns
tBALC	Byte(Word) Address Load Cycle	0.3	30	0.3	30	us
tBAL	Byte(Word) Address Load Time	100		100		us
tSRA	Status Register Access Time		100		120	ns
tCESR	$\overline{CE}$ Setup before S.R. Read	100		100		ns
tVCS	VCC Setup Time	2		2		us

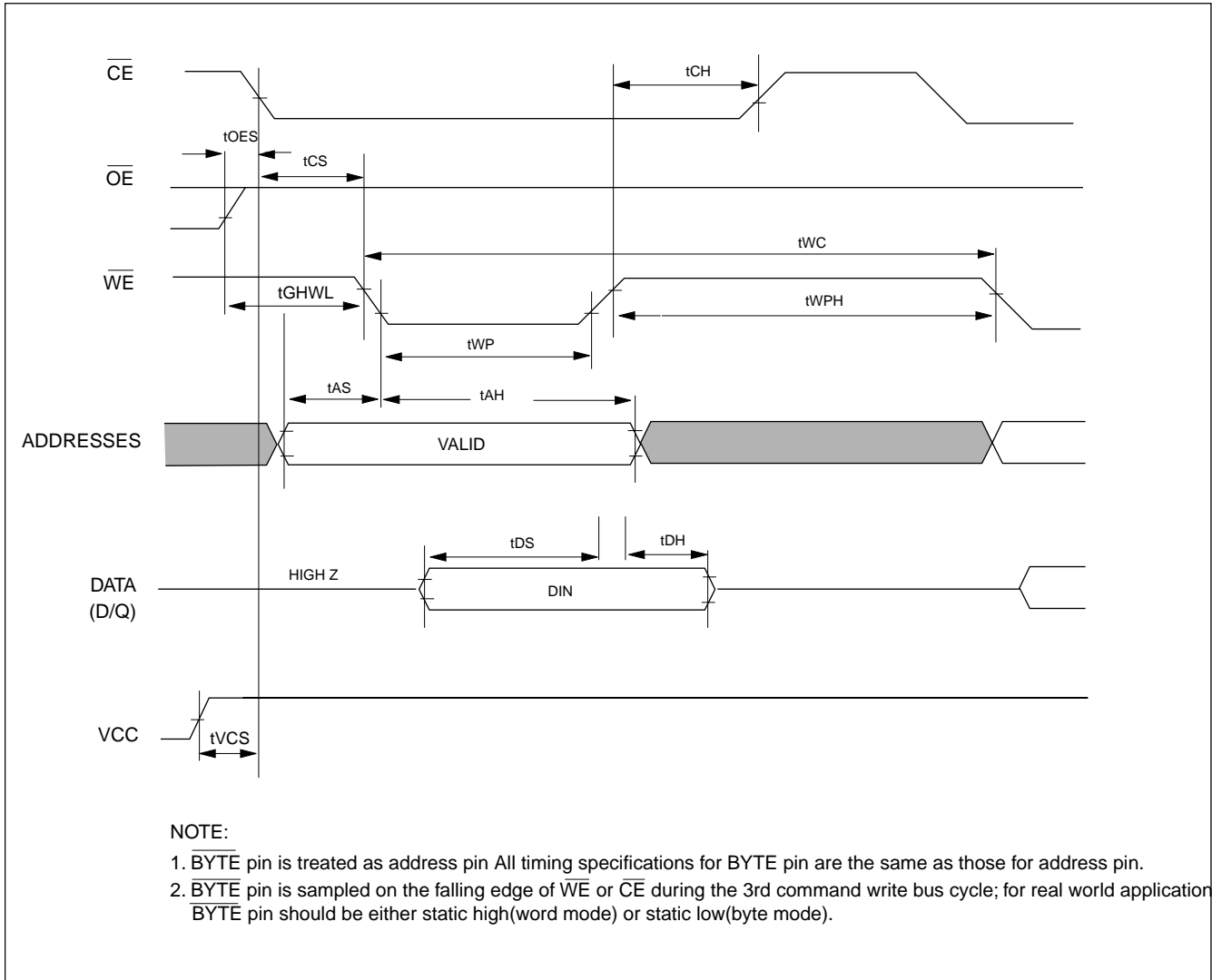
**Figure 7. COMMAND WRITE TIMING WAVEFORMS**

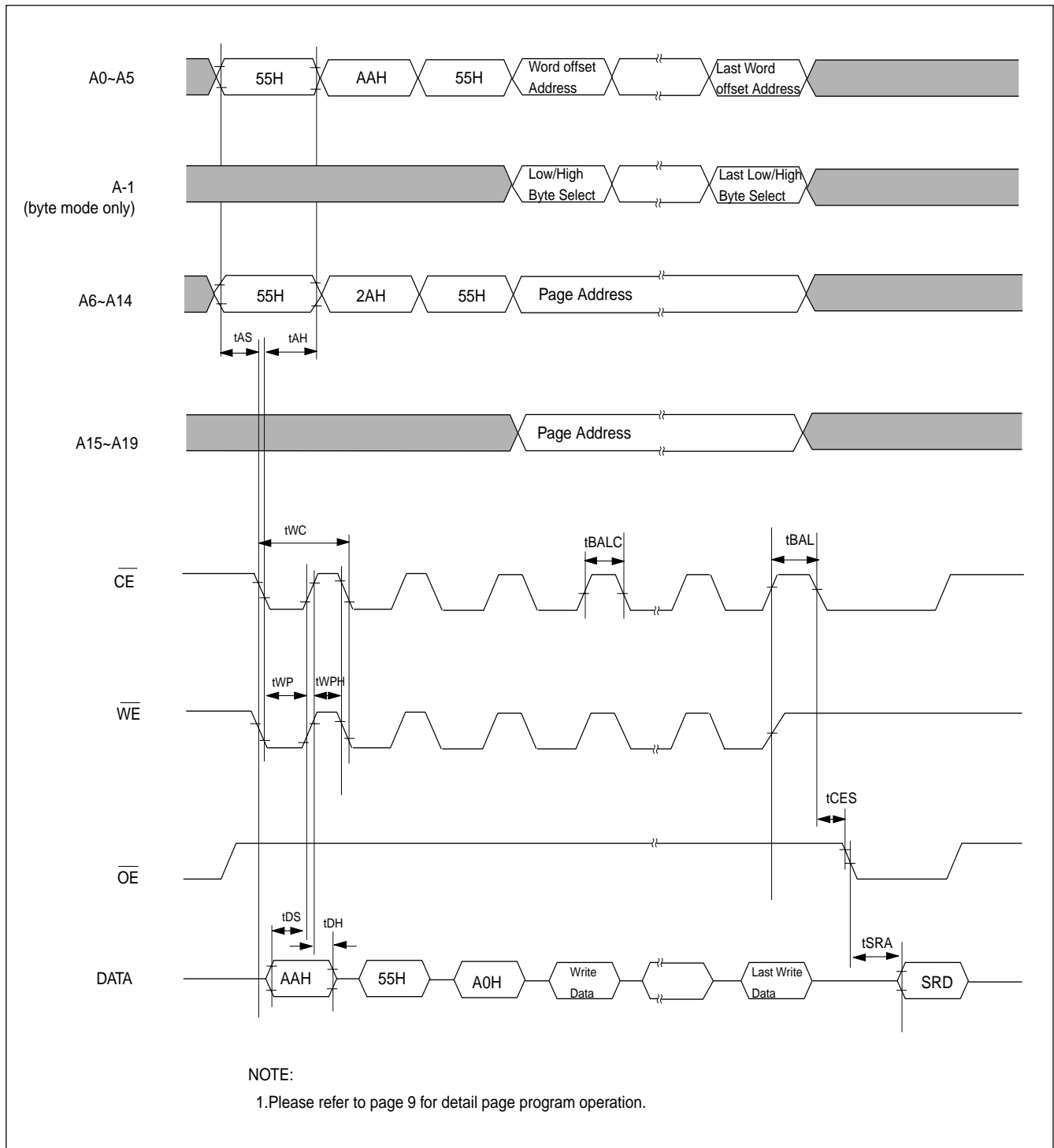
**Figure 8. AUTOMATIC PAGE PROGRAM TIMING WAVEFORMS**

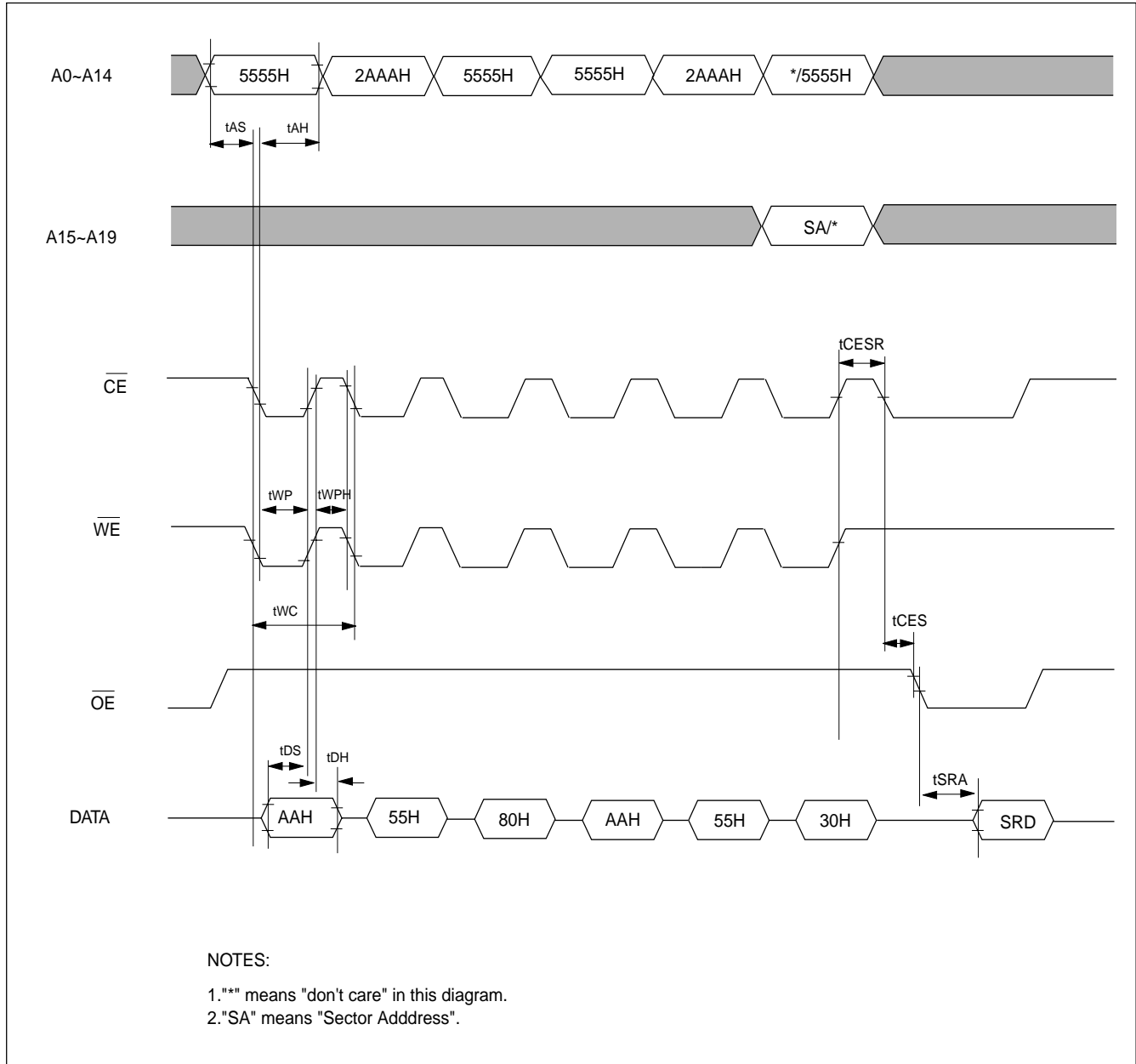
**Figure 9. AUTOMATIC SECTOR/CHIP ERASE TIMING WAVEFORMS**

**Figure 10. SECTOR PROTECTION ALGORITHM**

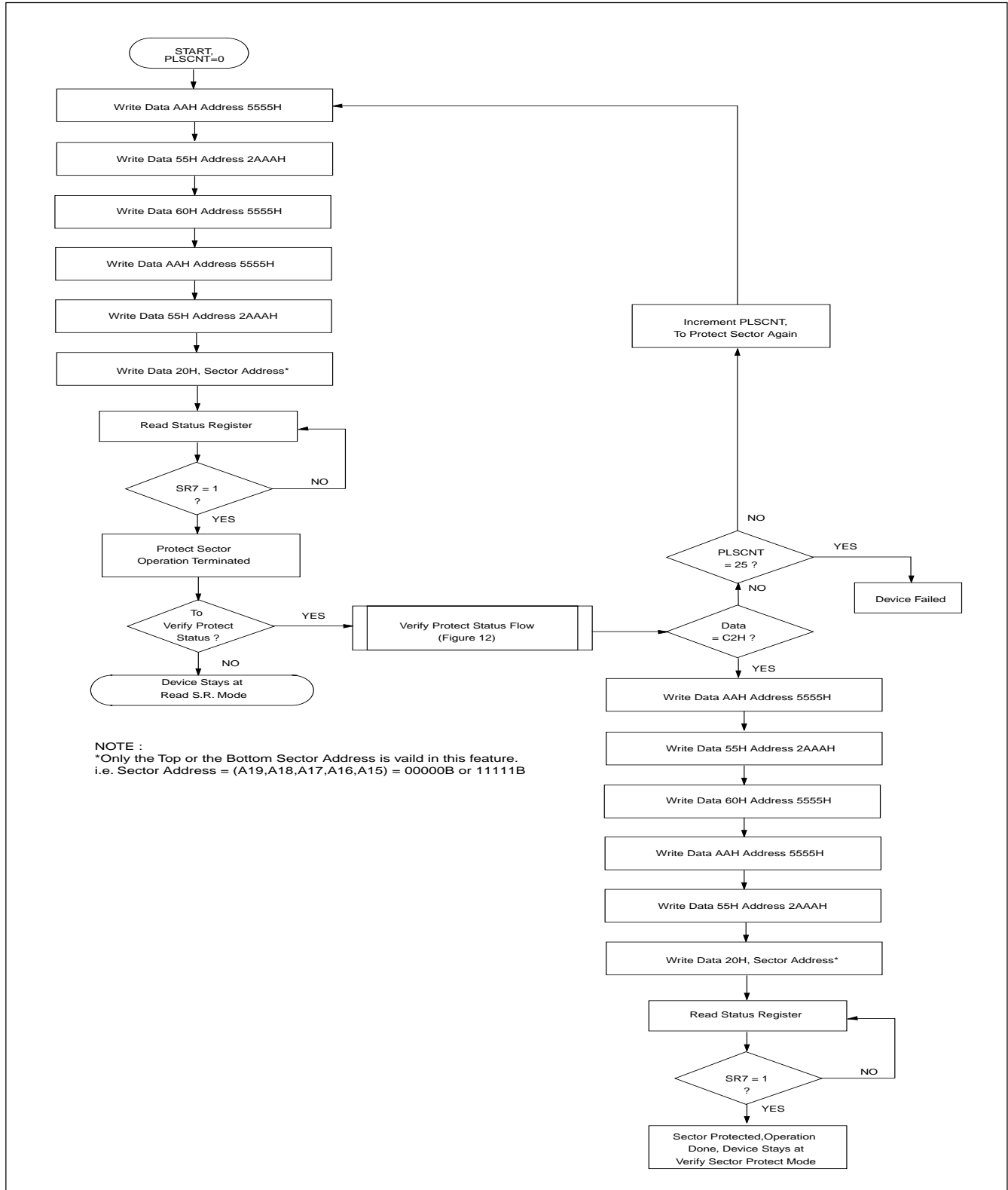

**Figure 11. SECTOR UNPROTECT ALGORITHM**

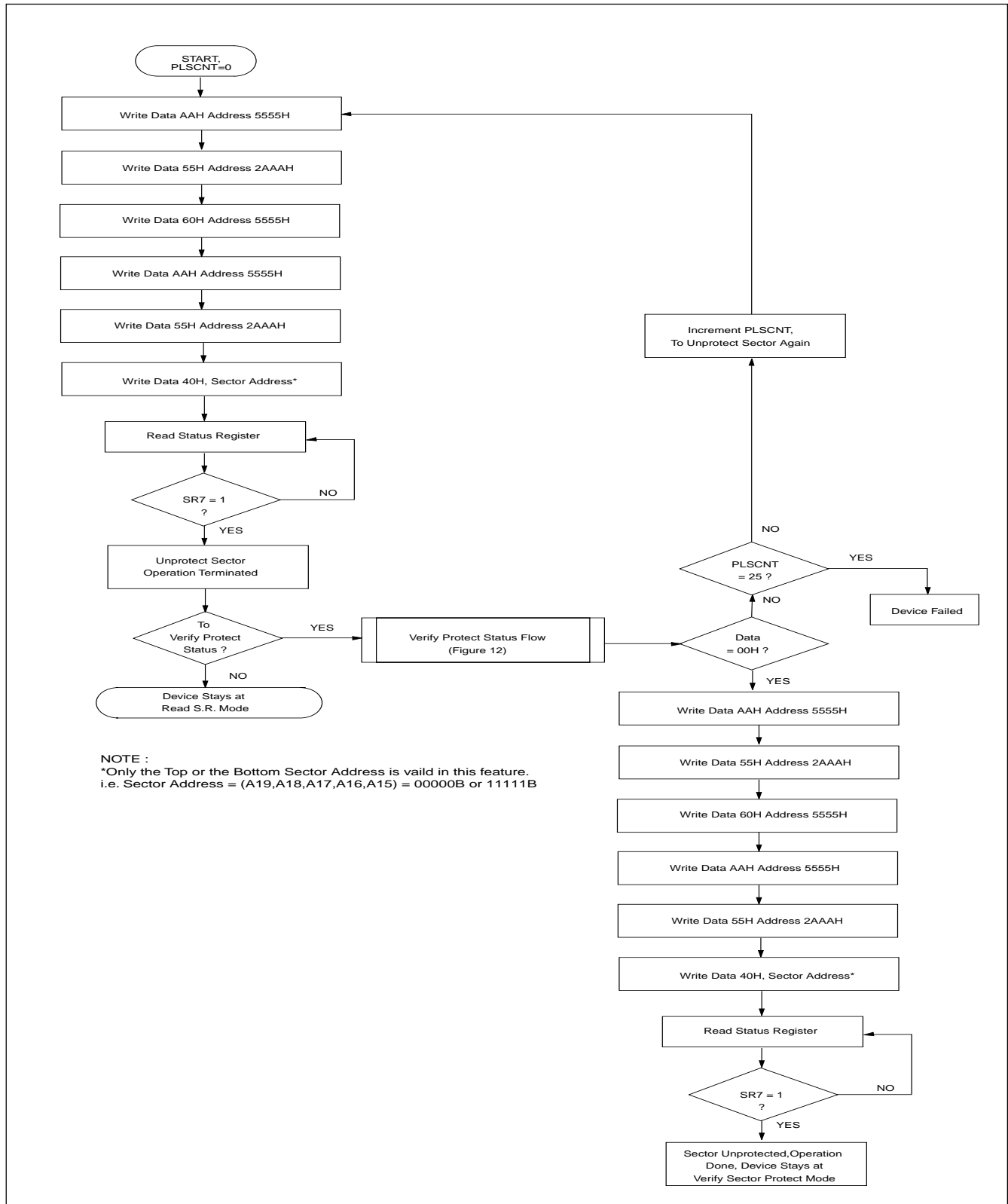

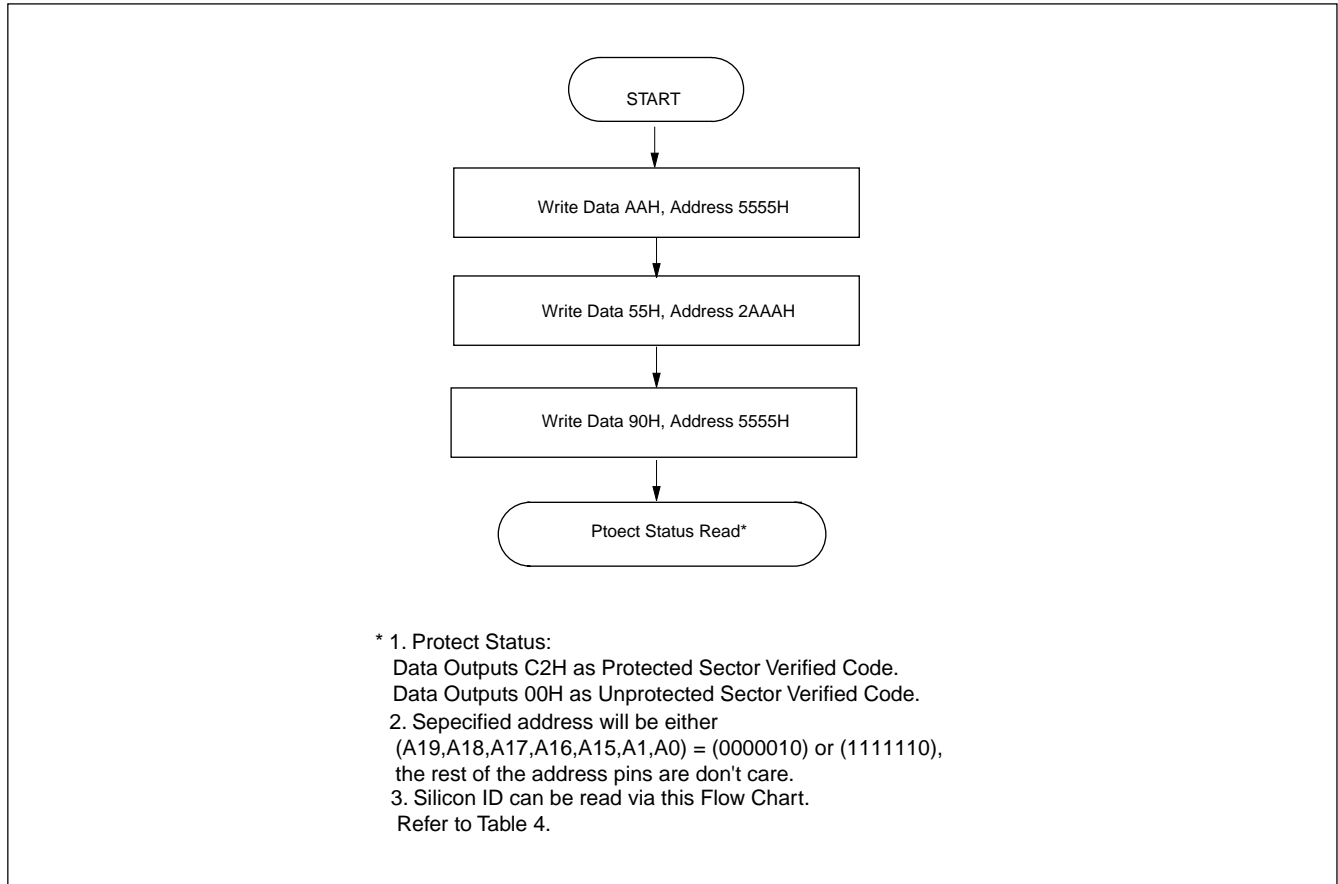
**Figure 12. VERIFY SECTOR PROTECT FLOW CHART**

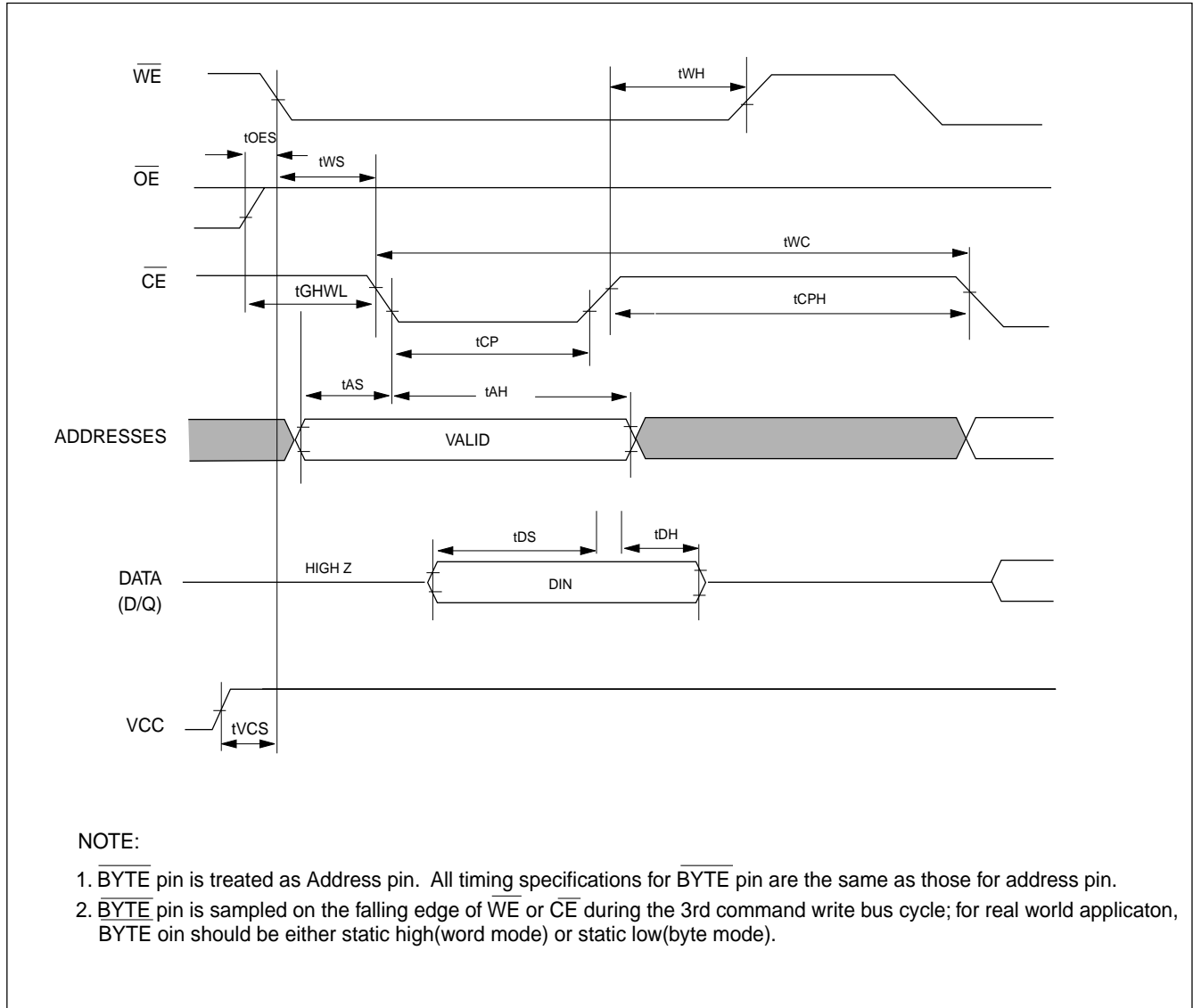
**Figure 13. COMMAND WRITE TIMING WAVEFORMS(Alternate  $\overline{CE}$  Controlled)**

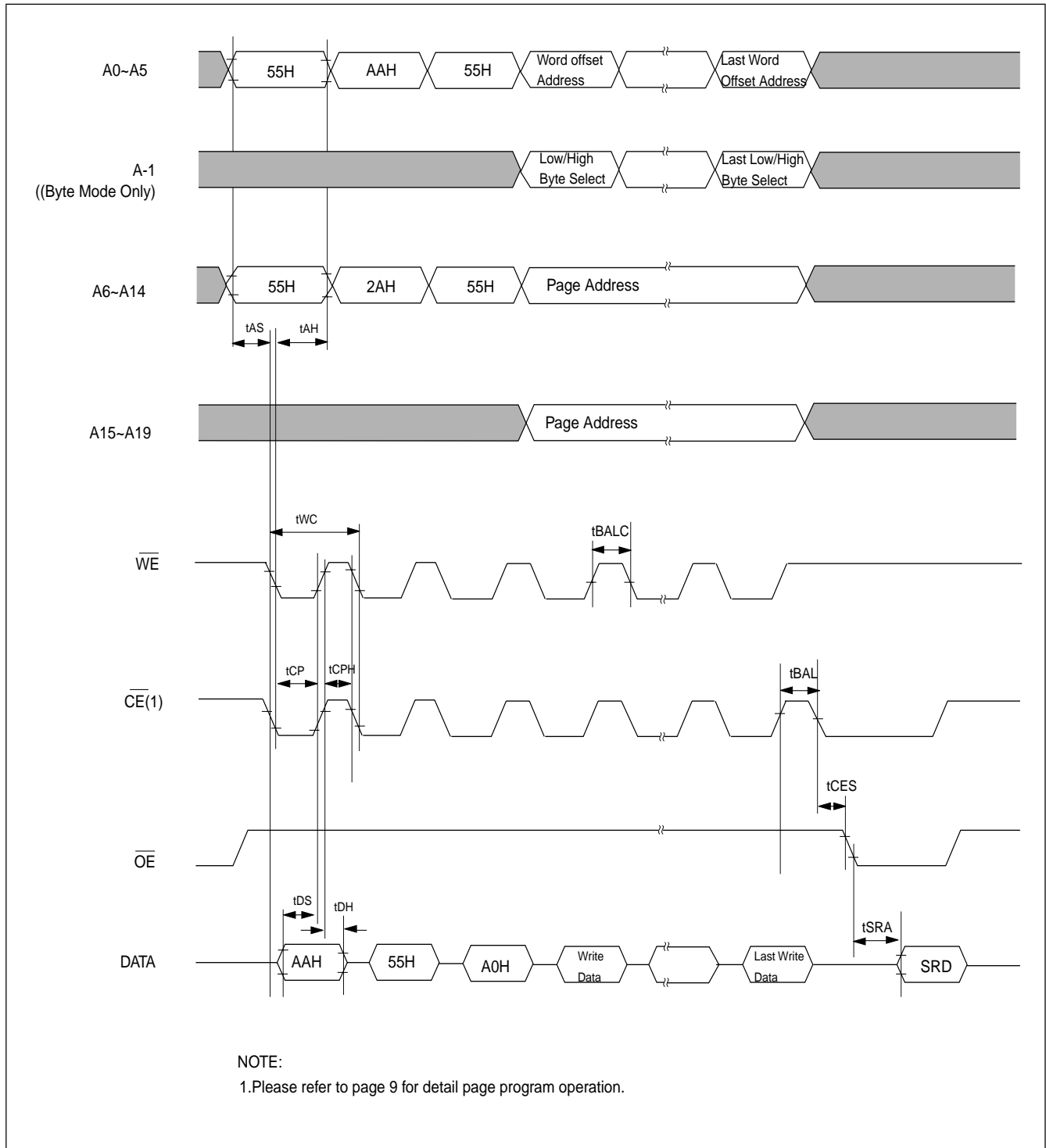

**Figure 14. AUTOMATIC PAGE PROGRAM TIMING WAVEFORM(Alternate  $\overline{CE}$  Controlled)**

**ERASE AND PROGRAMMING PERFORMANCE**

PARAMETER	LIMITS			UNITS
	MIN.	TYP.	MAX.	
Chip/Sector Erase Time		200	2000	ms
Page Programming Time		5	500	ms
Chip Programming Time		80	800	sec
Byte Program Time		40	4000	us
Erase/Program Cycles	10,000			Cycles

- 1.All number are sampled, not 100% tested.
- 2.Typing values are measured at 25°C, VCC=3.3V

**LATCH-UP CHARACTERISTICS**

	MIN.	MAX.
Input Voltage with respect to GND on all pins except I/O pins	-1.0V	6.6V
Input Voltage with respect to GND on all I/O pins	-1.0V	Vcc + 1.0V
Current	-100mA	+100mA
Includes all pins except Vcc. Test conditions: Vcc = 3.3V, one pin at a time.		

**ORDERING INFORMATION****PLASTIC PACKAGE**

<b>PART NO.</b>	<b>Access Time (ns)</b>	<b>Operating Current MAX.(mA)</b>	<b>Standby Current MAX.(uA)</b>	<b>PACKAGE</b>
MX29L1611MC-75	75	50	20	44 Pin SOP
MX29L1611MC-90	90	50	20	44 Pin SOP
MX29L1611MC-10	100	50	20	44 Pin SOP
MX29L1611MC-12	120	50	20	44 Pin SOP
MX29L1611TC-75	75	50	20	48 Pin TSOP (Normal Type)
MX29L1611TC-90	90	50	20	48 Pin TSOP (Normal Type)
MX29L1611TC-10	100	50	20	48 Pin TSOP (Normal Type)
MX29L1611TC-12	120	50	20	48 Pin TSOP (Normal Type)

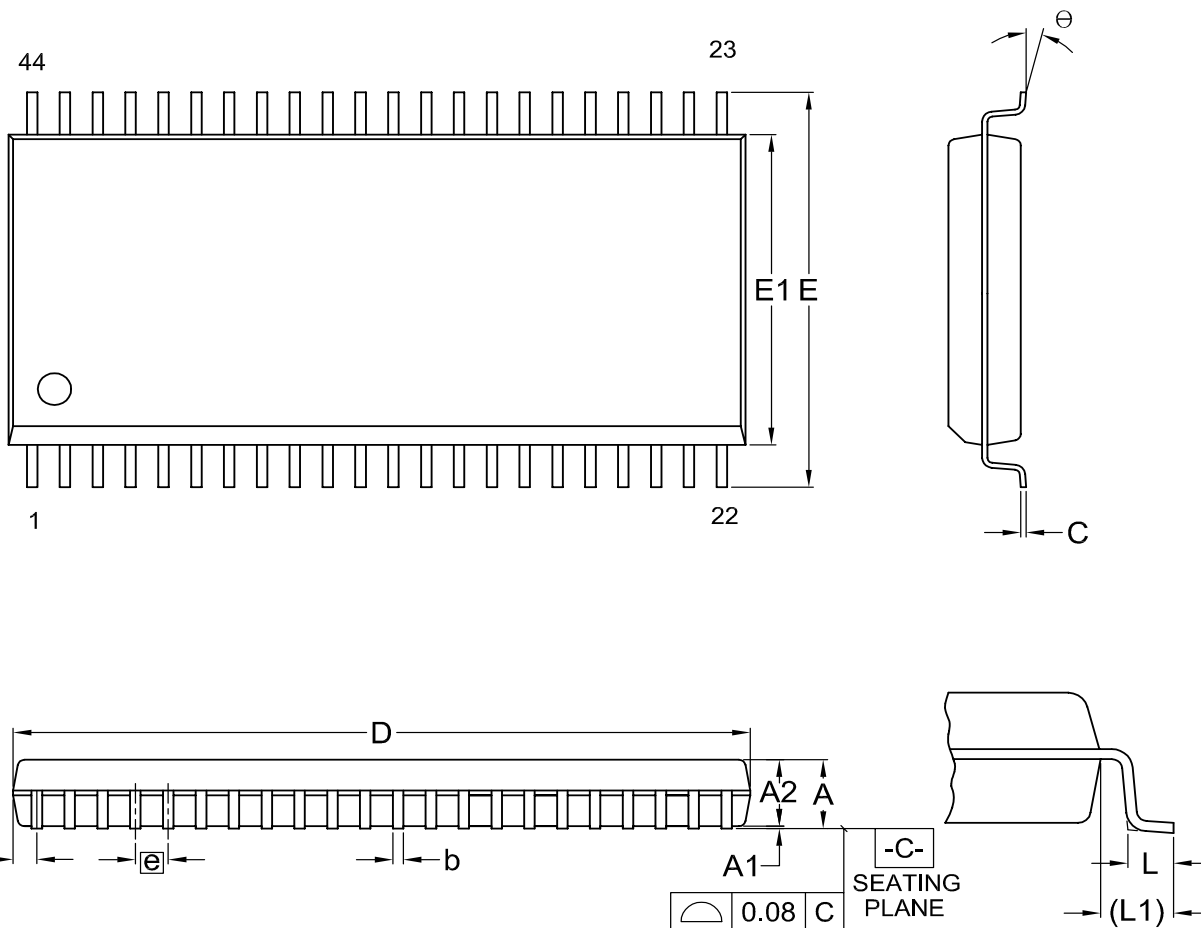
**PACKAGE INFORMATION**
**Title: Package Outline for SOP 44L (500MIL)**

Dimensions (inch dimensions are derived from the original mm dimensions)

SYMBOL		A	A1	A2	b	C	D	E	E1	e	L	L1	S	$\theta$
mm	Min.	---	0.10	2.59	0.36	0.15	28.37	15.83	12.47		0.56	1.51	0.78	0
	Nom.	---	0.15	2.69	0.41	0.20	28.50	16.03	12.60	1.27	0.76	1.71	0.91	5
	Max.	3.00	0.20	2.80	0.51	0.25	28.63	16.23	12.73		0.96	1.91	1.04	10
Inch	Min.	---	0.004	0.102	0.014	0.006	1.117	0.623	0.491		0.022	0.059	0.031	0
	Nom.	---	0.006	0.106	0.016	0.008	1.122	0.631	0.496	0.050	0.030	0.067	0.036	5
	Max.	0.118	0.008	0.110	0.020	0.010	1.127	0.639	0.501		0.038	0.075	0.041	10

DWG.NO.	REVISION	REFERENCE			ISSUE DATE
		JEDEC	EIAJ		
6110-1405	5	MO-175			09-24-'02

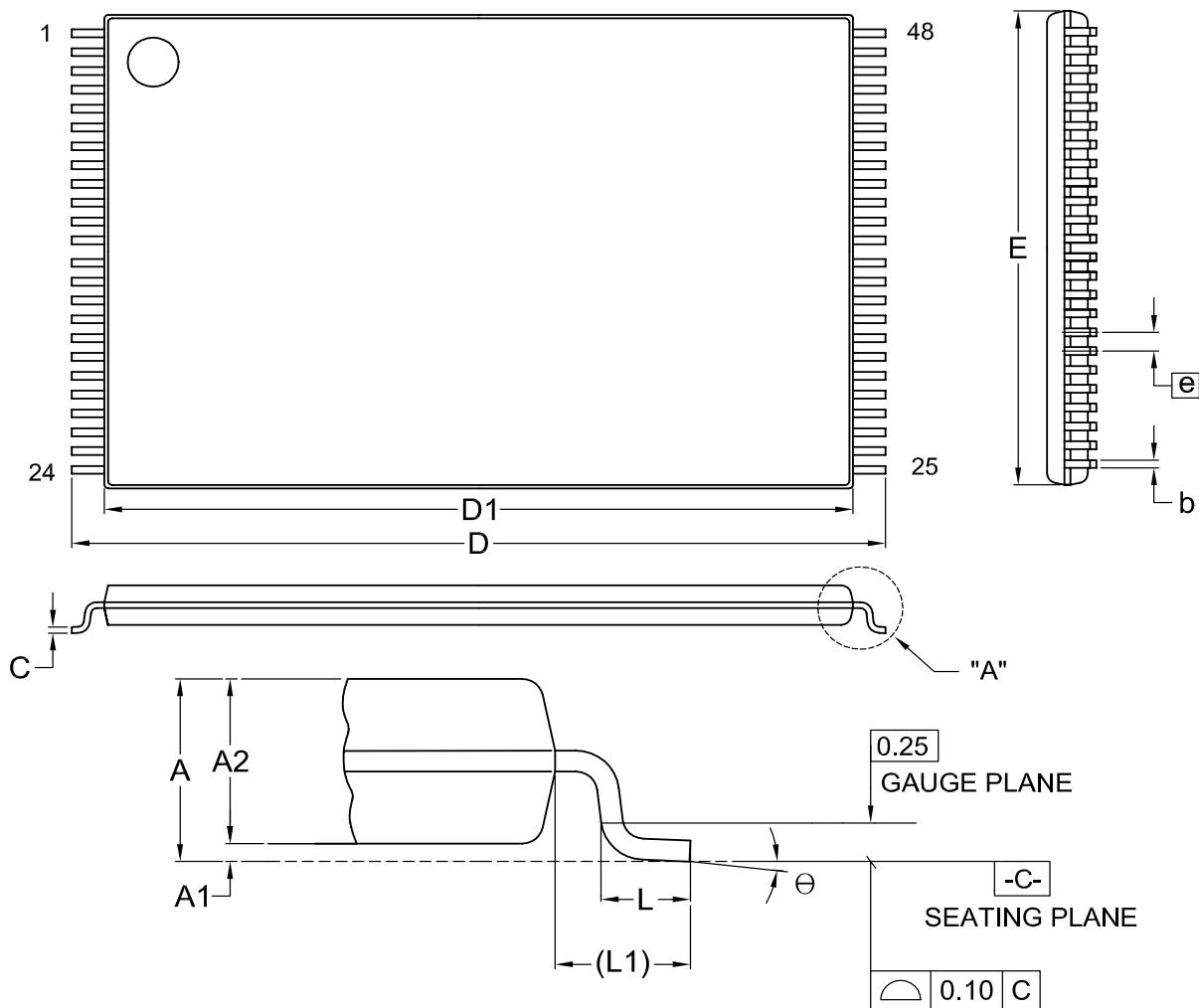
**Title: Package Outline for TSOP(I) 48L (12X20mm)NORMAL FORM**

**DETAIL "A"**

Dimensions (inch dimensions are derived from the original mm dimensions)

SYMBOL		A	A1	A2	b	C	D	D1	E	e	L	L1	$\theta$
UNIT													
mm	Min.	---	0.05	0.95	0.17	0.10	19.80	18.30	11.90		0.50	0.70	0
	Nom.	---	0.10	1.00	0.20	0.13	20.00	18.40	12.00	0.50	0.60	0.80	5
	Max.	1.20	0.15	1.05	0.27	0.21	20.20	18.50	12.10		0.70	0.90	8
Inch	Min.	---	0.002	0.037	0.007	0.004	0.780	0.720	0.469		0.020	0.028	0
	Nom.	---	0.004	0.039	0.008	0.005	0.787	0.724	0.472	0.020	0.024	0.031	5
	Max.	0.047	0.006	0.041	0.011	0.008	0.795	0.728	0.476		0.028	0.035	8

DWG.NO.	REVISION	REFERENCE			ISSUE DATE
		JEDEC	EIAJ		
6110-1607	6	MO-142			09-24-'02

**HISTORY STORY**

<b>Revision</b>	<b>Description</b>	<b>Page</b>	<b>Date</b>
1.1	Correct Page Programming waveform and delete RY/BY,PWD wafewaves on Page 26 & Page 32 respectively		APR/10/1998
1.2	Revise page read speed to 30ns @CL=35pF on Page 1 & Page 19 Correct statement of ABORT MODE on Page 13.		SEP/09/1998
1.3	Add 48 TSOP(I) package, and new read speed grade random access 120ns, page mode access 40ns	P1,2,21,24	NOV/26/1998
1.4	Modify the data for erase and programming performance	P33	JUN/28/1999
1.5	Add in ordering information	P34	JUL/15/1999
1.6	Revised Package Information	P35,36	JUL/22/1999
1.7	Revised random access time 100/120-->75/90 Revised page mode access time 30/40-->25/30 Revised device power supply VCC Revised switching test circuits Revised DC Characteristic Vcc=3.3V ±10%-->2.7V~3.6V Revised AC Characteristic Revised access time in package information	P1 P1 P4 P19 P20 P21 P34	DEC/03/1999
1.8	Revised Fast Pagemode Access Time : 25/30 -->30/35 Add 48 TSOP(Reverse Type)	P1	JAN/18/2000
1.9	Modify AC Characteristics--tSRA MIN:75/90-->MAX:75/90	P24	FEB/10/2000
2.0	Add in note in the AC Characteristics	P21	FEB/21/2000
2.1	Add 120ns in for fast random access time Add MX29L1611-12 in AC Characteristics Add MX29L1611MC-12 and MX29L1611TC-12	P1 P21,24 P34	FEB/29/2000
2.2	Add 100ns in for fast random access time Add MX29L1611-10 in AC Characteristics Add MX29L1611MC-10 and MX29L1611TC-10	P1 P21,25 P34	JUN/09/2000
2.3	Modify Switching Test Waveform Vcc/ 0 ---> 2.4V/0.45V Modify Test Conditions : Input pulse levels: 0/Vcc ---> 0.45V/2.4V Reference level for measuring timing Vcc/2 -->1.5V	P19 P21 P21	JUN/22/2000
2.4	Remove 48-pin Reverse TSOP in Package Information	P37	NOV/06/2001
2.5	1. To modify Package Information	P36,37	NOV/21/2002



**MX29L1611**

---

---

**MACRONIX INTERNATIONAL Co., LTD.**

**HEADQUARTERS:**

TEL: +886-3-578-6688

FAX: +886-3-563-2888

**EUROPE OFFICE:**

TEL: +32-2-456-8020

FAX: +32-2-456-8021

**JAPAN OFFICE:**

TEL: +81-44-246-9100

FAX: +81-44-246-9105

**SINGAPORE OFFICE:**

TEL: +65-348-8385

FAX: +65-348-8096

**TAIPEI OFFICE:**

TEL: +886-2-2509-3300

FAX: +886-2-2509-2200

**MACRONIX AMERICA, INC.**

TEL: +1-408-453-8088

FAX: +1-408-453-8488

**CHICAGO OFFICE:**

TEL: +1-847-963-1900

FAX: +1-847-963-1909

**[http : //www.macronix.com](http://www.macronix.com)**