

# DATA SHEET

## **PCF5078**

**Power amplifier controller for GSM  
and PCN systems**

Product specification  
File under Integrated Circuits, IC17

1999 Apr 12

# Power amplifier controller for GSM and PCN systems

## PCF5078

### FEATURES

- Compatible with baseband interface family PCF5073x
- Two power sensor inputs
- Temperature compensation of sensor signal
- Active filter for DAC input
- Power Amplifier (PA) protection against mismatching
- Bias current source for detector diodes
- Generation of pre-bias level for PA at start of burst (home position)
- Possibility to adapt home position by external components
- Applicable for a wide range of silicon and GaAs power amplifiers.

### APPLICATIONS

- Global System for Mobile communication (GSM)
- Personal Communications Network (PCN) systems.

### GENERAL DESCRIPTION

This CMOS device integrates an amplifier for the detected RF voltage from the sensor, an integrator and an active filter to build a PA control loop for cellular systems with a small amount of passive components.

### QUICK REFERENCE DATA

SYMBOL	PARAMETER	MIN.	TYP.	MAX.	UNIT
$V_{DD}$	supply voltage	2.4	3.6	5.0	V
$I_{DD(tot)}$	total supply current	–	–	6	mA
$T_{amb}$	operating ambient temperature	–40	–	+85	°C

### ORDERING INFORMATION

TYPE NUMBER	PACKAGE		
	NAME	DESCRIPTION	VERSION
PCF5078T	TSSOP8	plastic thin shrink small outline package; 8 leads; body width 3.0 mm	SOT505-1

Power amplifier controller for GSM and PCN systems

PCF5078

BLOCK DIAGRAM

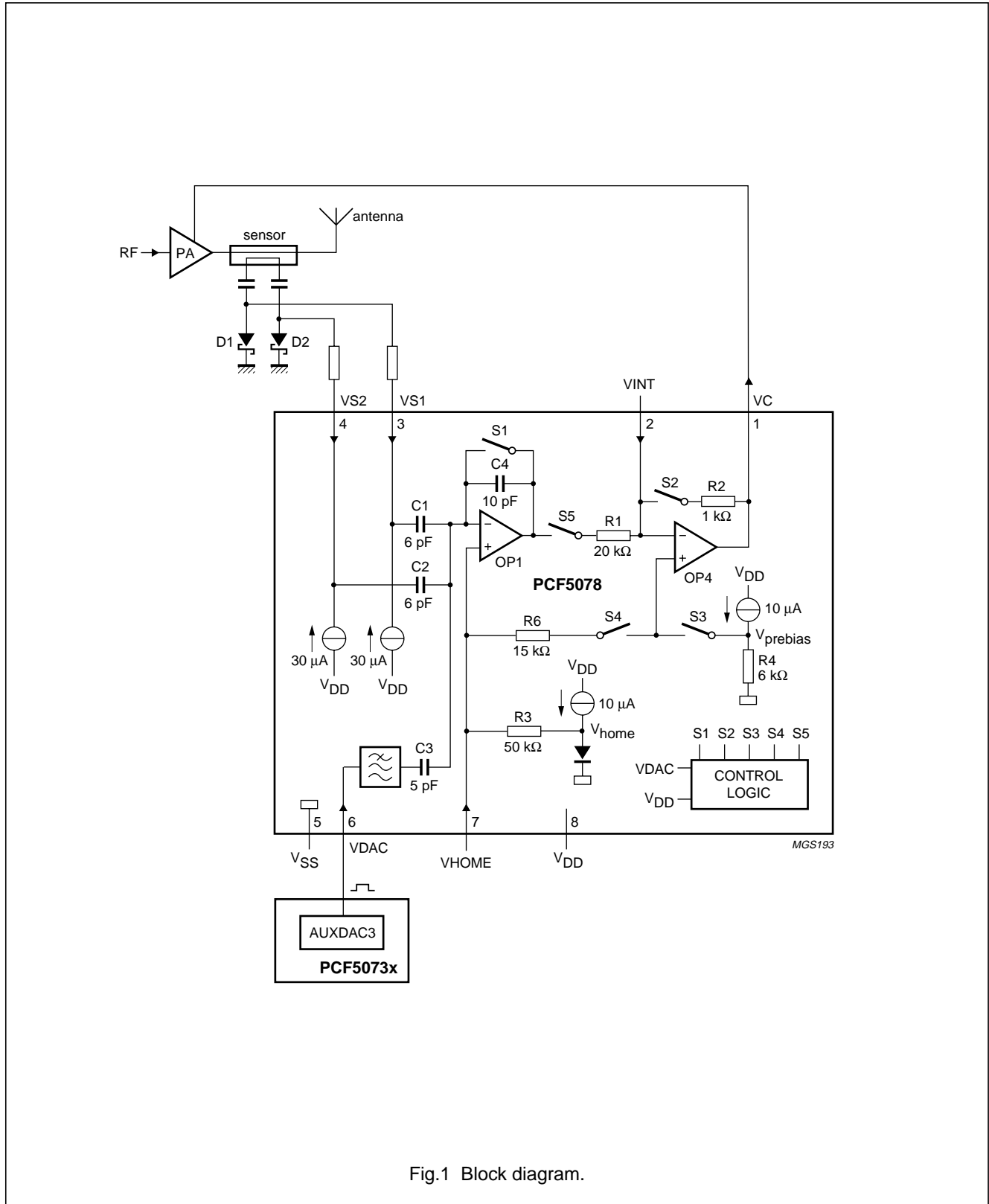

Fig.1 Block diagram.

# Power amplifier controller for GSM and PCN systems

PCF5078

## PINNING

SYMBOL	PIN	DESCRIPTION
VC	1	PA control output voltage
VINT	2	negative integrator input
VS1	3	sensor signal input 1
VS2	4	sensor signal input 2
V <sub>SS</sub>	5	ground supply
VDAC	6	DAC input voltage
VHOME	7	home position input voltage
V <sub>DD</sub>	8	supply voltage

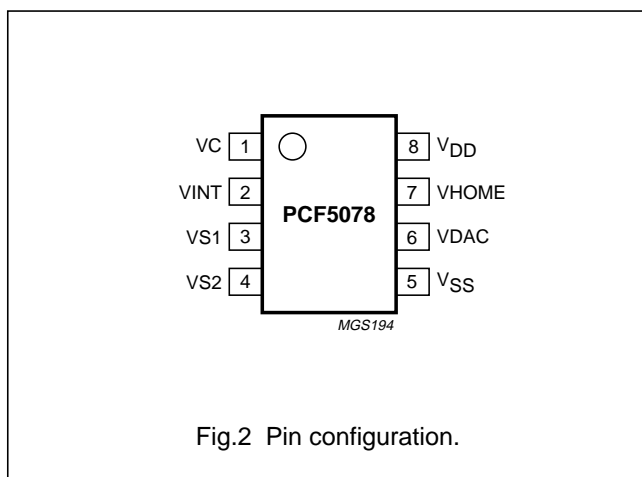

## FUNCTIONAL DESCRIPTION

### General

The PCF5078 integrates an amplifier for the detected RF voltage from the sensor, an integrator and an active filter to build a PA control loop with a small amount of passive components.

The sensor amplifier is able to amplify signals from a RF power detector in a range of  $-20$  to  $+15$  dBm. This complies to the PA output power range of GSM and PCN systems when a directional coupler with 20 dB attenuation is used.

The Schottky diode for power detection (sensor) is biased by an integrated current source of  $30 \mu\text{A}$ . Variations of the forward voltage of the diodes with the temperature have no influence on the measured signal, because they are cancelled by sampling around the switched capacitor operational amplifier OP1 (see Fig.1).

An external Digital-to-Analog Converter (DAC) with 10-bit resolution is necessary to control the loop e.g. the AUXDAC3 of the baseband interface family PCF5073x.

An integrated active filter smooths the voltage steps of the DAC and avoids a feedthrough of the DAC harmonics into the modulation spectra of the PA.

The DAC signal and the sensor signal are added by operational amplifier OP1. The voltage difference of both signals is integrated by operational amplifier OP4, which provides the PA control voltage on pin VC. The integration is performed by means of an external capacitance  $C_{VINT}$  connected between pins VINT and VC.

The shape of the rising and falling power burst edges can be determined by means of the DAC voltage (see Fig.3).

### Power-down mode

During the not used time slots in Time Division Multiple Access (TDMA) systems, the PCF5078 must be turned off by switching off the supply voltage on pin V<sub>DD</sub>.

### Initial conditions and start-up

The PCF5078 has been designed to operate in bursts as required in TDMA systems. For each time slot to be transmitted it must be powered-up by switching on the supply voltage. This allows a proper initialization of switches S1 to S5.

During start-up switches S1, S2 and S3 are closed and switches S4 and S5 are opened (see Fig.4).

The forward voltages on the Schottky diodes are sampled on capacitors C1 and C2, respectively, because switch S1 is closed. Moreover, the control voltage on pin VC is initially forced to pre-bias level  $V_{prebias}$  because switches S2 and S3 are closed and switch S4 is opened.

Switch S1 is opened after a fixed time the supply voltage has been switched on and then the circuit is ready. This time is defined on-chip and can be maximum  $45 \mu\text{s}$ . Once switch S1 is open, a ramp signal with a minimum amplitude of 25 mV applied on pin VDAC determines opening of switch S3 and closing of switch S4 with a delay of maximum  $3 \mu\text{s}$  with respect to the start of the ramp.

After opening switch S3, the control voltage on pin VC rises in a fixed amount of time to the home position level so biasing the PA to the beginning of the active range of its control curve. Switch S2 remains closed during this typical time of  $2 \mu\text{s}$ . When switch S2 is opened, switch S5 is closed allowing the transfer of any signal coming from amplifier OP1.

---

## Power amplifier controller for GSM and PCN systems

---

PCF5078

After this preset, the control voltage is free to increase according to the control loop if RF input is present (see Fig.3).

For higher DAC ramp steps the delay time of opening switch S3 (and closing switch S4) is reduced. On the contrary, the delay time between opening switch S2 with respect to opening switch S3 (and closing switch S4) remains unchanged.

For a correct start-up it is required that the rising time of the supply voltage is maximum 20  $\mu$ s.

### End of a burst

For a proper down ramp, the final value of the DAC input voltage should be below the value at the beginning of the burst and so be able to really shut-off the PA (see Fig.5). This means the code programmed for the last bit of the DAC down ramp (CODE<sub>END</sub>) has to be lower than the initial value of the up ramp (CODE<sub>START</sub>). Moreover, the last code must be maintained until the supply voltage has been switched off.

When the voltage on pin VC is detected to be lower than  $V_{VHOME}$  a built-in mechanism forces the voltage on pin VC to  $V_{prebias}$  by closing switches S1, S2 and S3 and by opening switches S4 and S5.

For proper operation, the supply voltage should be switched off at least 15  $\mu$ s later with respect to the end of the down ramp on pin VDAC.

### PA protection against mismatching

A second sensor amplified input is integrated into the PCF5078 for measuring the reflected wave of the directional coupler. The signal is added to the measured RF power signal (see Fig.3). When mismatching at the output of the PA occurs the power is reduced. A high Voltage Standing Wave Ratio (VSWR) at the output of the PA often occurs in systems where the PA is connected to the antenna via switches with low attenuation instead of using a duplex filter.

### Home position voltage

A forward voltage of an on-chip silicon diode is provided as the default home position voltage  $V_{home}$ . This voltage matches the requirements at the control input of most PAs and exhibits the same temperature coefficient.

However, if another value is needed for a certain PA the level can be adjusted by connecting external components to pin VHOME (see Figs 10 and 11). The home position voltage can be set between 200 and 1000 mV when using a capacitor of 50 pF connected between pins VINT and VC.

Power amplifier controller for GSM and PCN systems

PCF5078

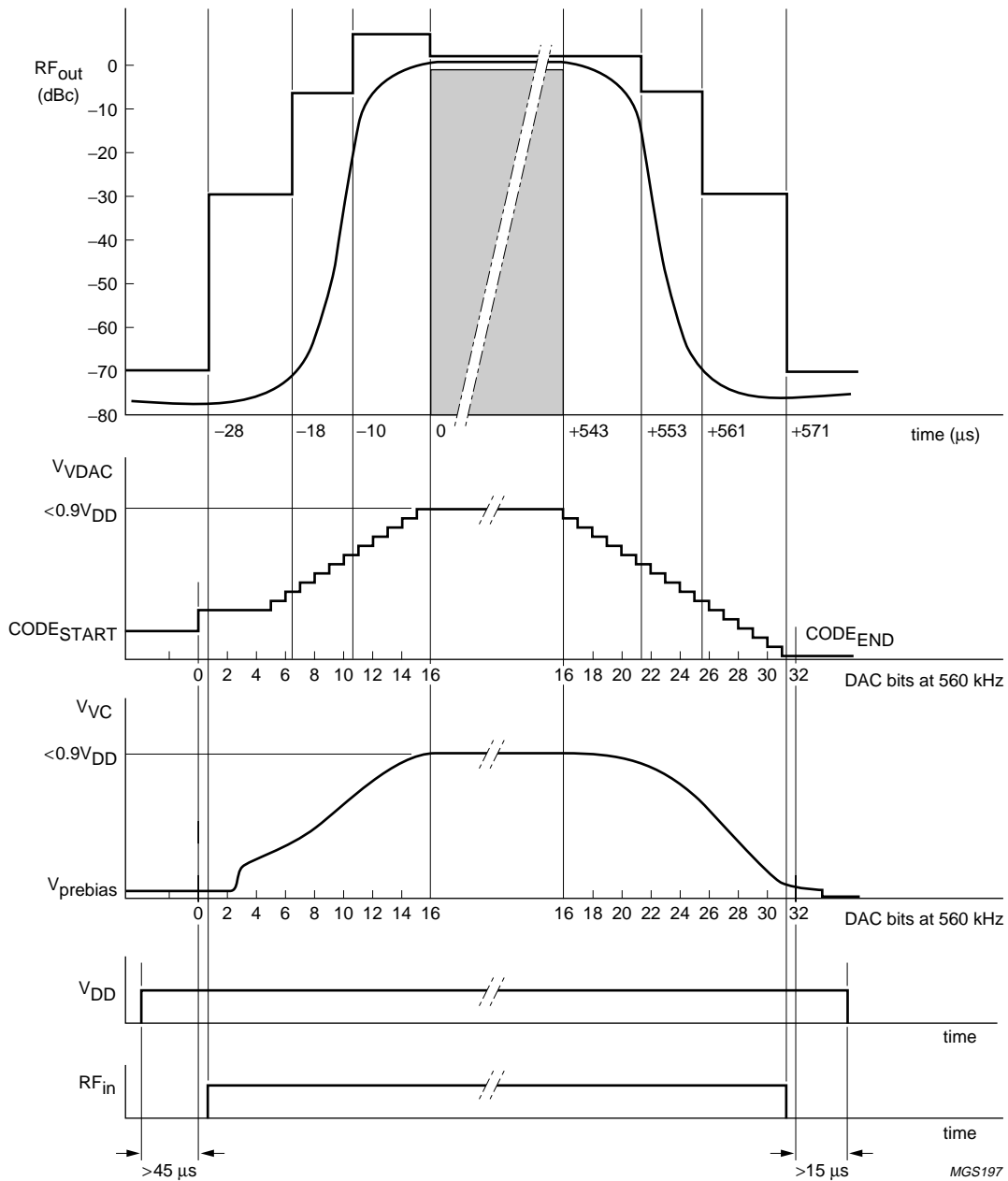
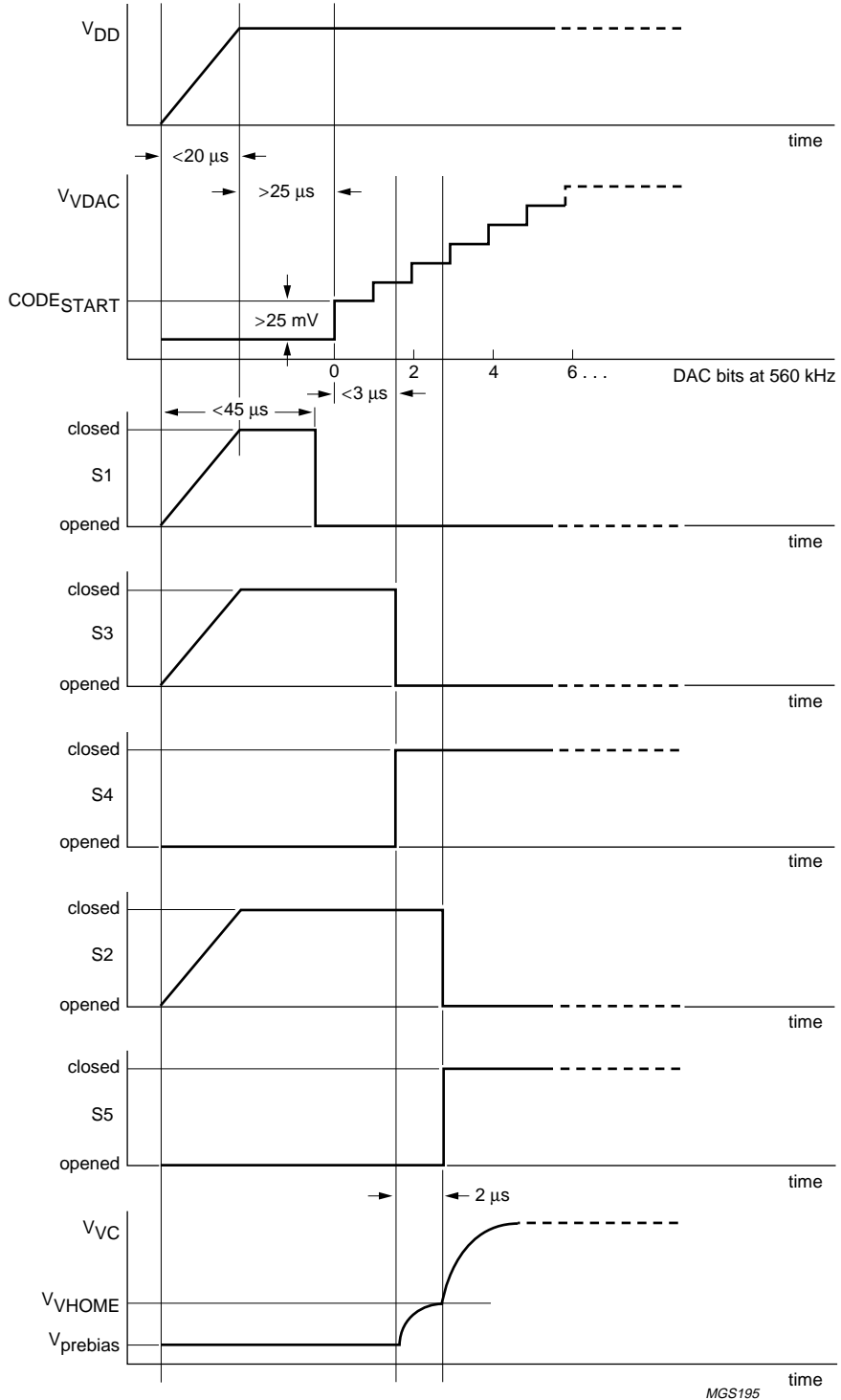

Fig.3 Timing diagram.

# Power amplifier controller for GSM and PCN systems

PCF5078



MGS195

Fig.4 Initialization and start of a burst diagram.

Power amplifier controller for GSM and PCN systems

PCF5078

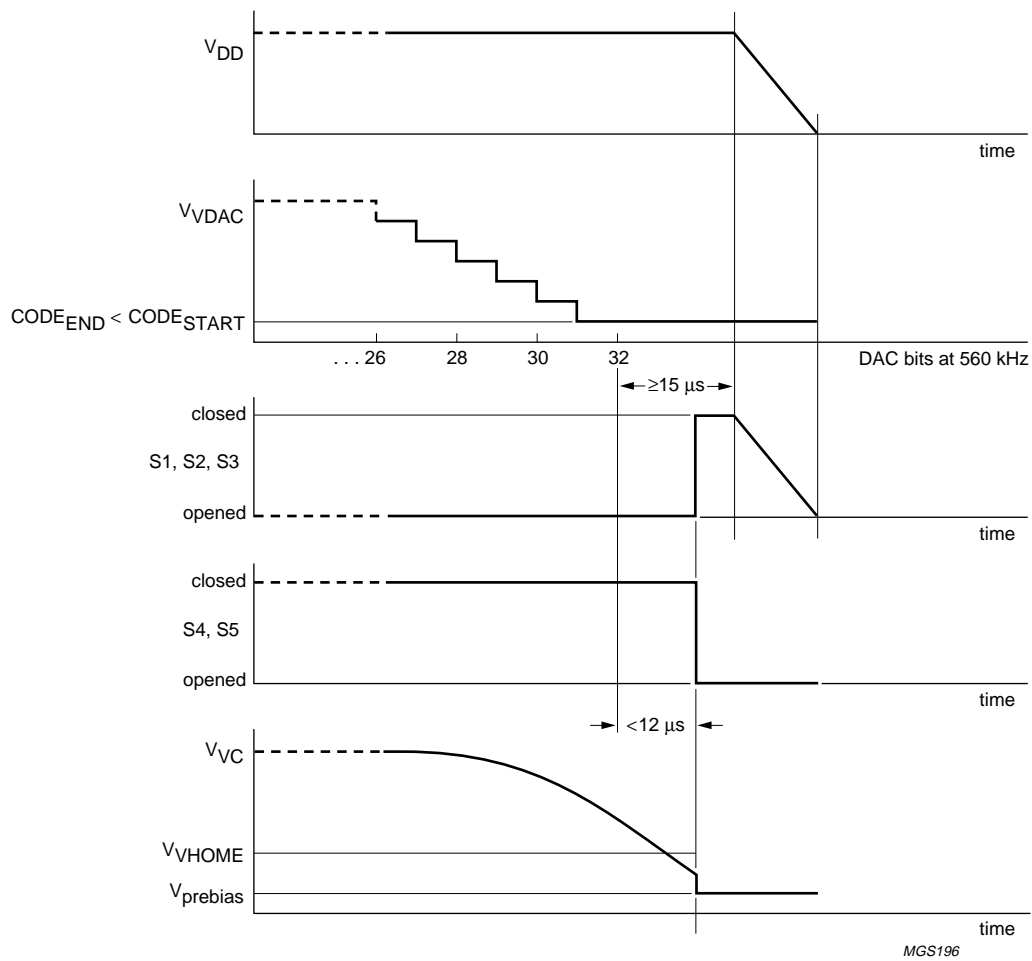

Fig.5 End of a burst diagram.



# Power amplifier controller for GSM and PCN systems

PCF5078

## LIMITING VALUES

In accordance with the Absolute Maximum Rating System (IEC 134).

SYMBOL	PARAMETER	MIN.	MAX.	UNIT
$V_{DD}$	supply voltage	2.4	6.0	V
$V_n$	DC voltage on pins VS2 and VS2	-3.0	+6.0	V
	all other pins	-0.5	+6.0	V
$I_n$	DC current on any signal pin	-10	+10	mA
$P_{tot}$	total power dissipation	-	315	mW
$T_{stg}$	storage temperature	-65	+150	°C
$T_{amb}$	operating ambient temperature	-40	+85	°C

## CHARACTERISTICS

$V_{DD} = 2.4$  to  $5$  V;  $T_{amb} = -40$  to  $+85$  °C; see Fig.1; unless otherwise specified.

SYMBOL	PARAMETER	CONDITIONS	MIN.	TYP.	MAX.	UNIT
<b>Supply</b>						
$V_{DD}$	supply voltage		2.4	3.6	5.0	V
$I_{DD(tot)}$	total supply current		-	-	6	mA
<b>Sensor input voltage</b>						
$V_{I(n)}$	input voltage on pins VS1 and VS2		-3	-	$V_{DD}$	V
<b>Bias current source</b>						
$I_{bias}$	detector diode bias current	no input signal; $T_{amb} = 25$ °C; see Fig.7				
		$V_{DD} = 2.4$ V	17	28	39	μA
		$V_{DD} = 5.0$ V	21	33	45	μA
$TC_{bias}$	temperature coefficient of bias current source		-	0.07	-	μA/K
<b>Home position voltage</b>						
$V_{home}$	internal home position voltage	$T_{amb} = 25$ °C	0.550	0.600	0.650	V
$TC_{home}$	temperature coefficient of internal home position voltage source		-	-2.1	-	mV/K
R3	resistor for internal home position voltage		-	50	-	kΩ
$V_{I(VHOME)}$	home position input voltage		200	-	1000 <sup>(1)</sup>	mV
<b>Low pass filter for DAC signal (3rd-order Bessel)</b>						
$f_{3dB}$	corner frequency		70	100	130	kHz

Power amplifier controller for GSM and PCN systems

PCF5078

SYMBOL	PARAMETER	CONDITIONS	MIN.	TYP.	MAX.	UNIT
<b>Integrator (OP4)</b>						
B <sub>G</sub>	gain bandwidth	C <sub>L</sub> = 120 pF; note 2	–	4	–	MHz
PSRR	power supply rejection ratio	at 217 Hz; V <sub>DD</sub> = 3 V; note 2	50	55	–	dB
SR <sub>pos</sub>	positive slew rate	V <sub>DD</sub> = 3 V; note 3	3.5	4.5	–	V/μs
SR <sub>neg</sub>	negative slew rate	V <sub>DD</sub> = 3 V; note 3	3.5	4.5	–	V/μs
V <sub>O(min)</sub>	minimum output voltage	T <sub>amb</sub> = 25 °C; see Fig.8	–	–	0.2	V
V <sub>O(max)</sub>	maximum output voltage	R <sub>L</sub> = 700 Ω; see Fig.6	0.85V <sub>DD</sub>	–	–	V
<b>Capacitors C1, C2, C3 and C4</b>						
M	matching ratio accuracy between capacitances		–	1	–	%

Notes

1. For C<sub>VINT</sub> = 50 pF.
2. Guaranteed by design.
3. Slew rates are measured between 10% and 90% of output voltage level with an load of approximately 40 pF to ground.

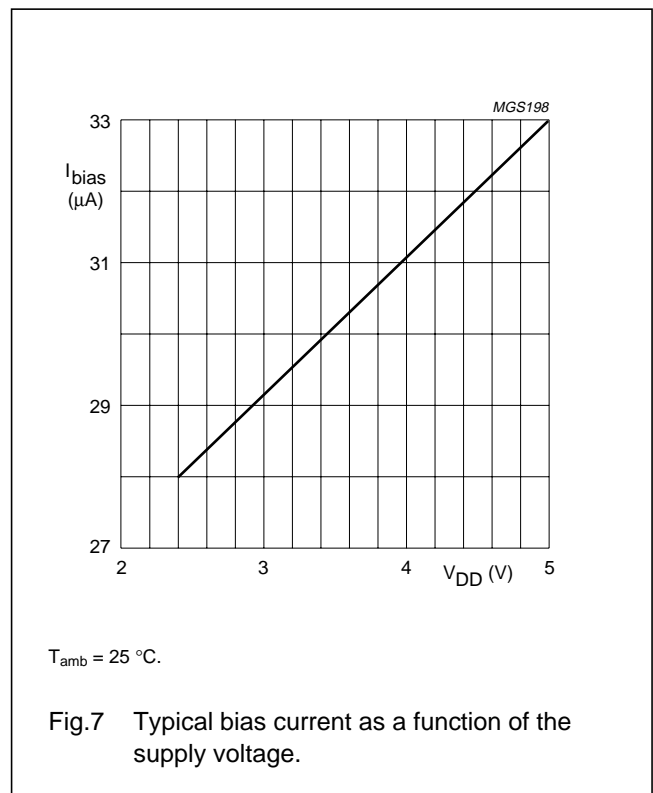
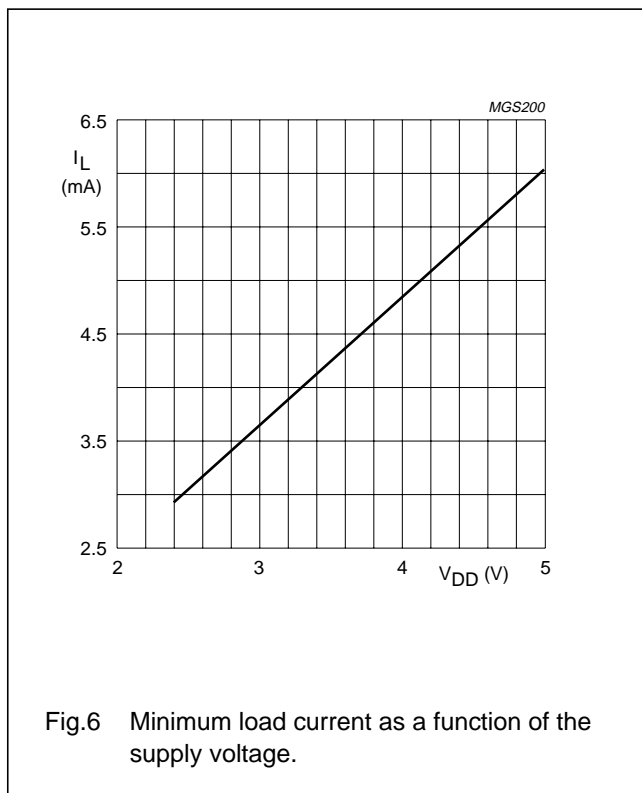

Power amplifier controller for GSM and PCN systems

PCF5078

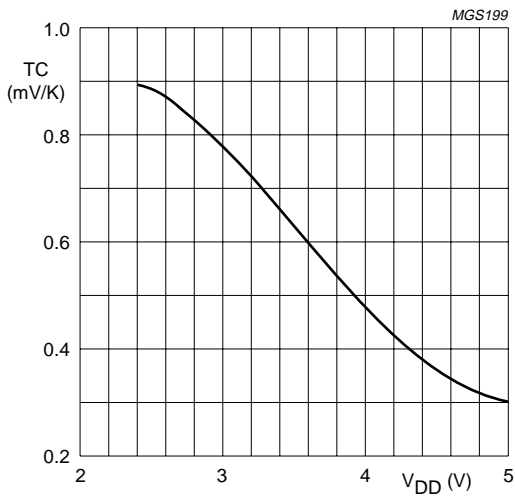

Fig.8 Temperature coefficient of the minimum output voltage as a function of the supply voltage.

APPLICATION INFORMATION

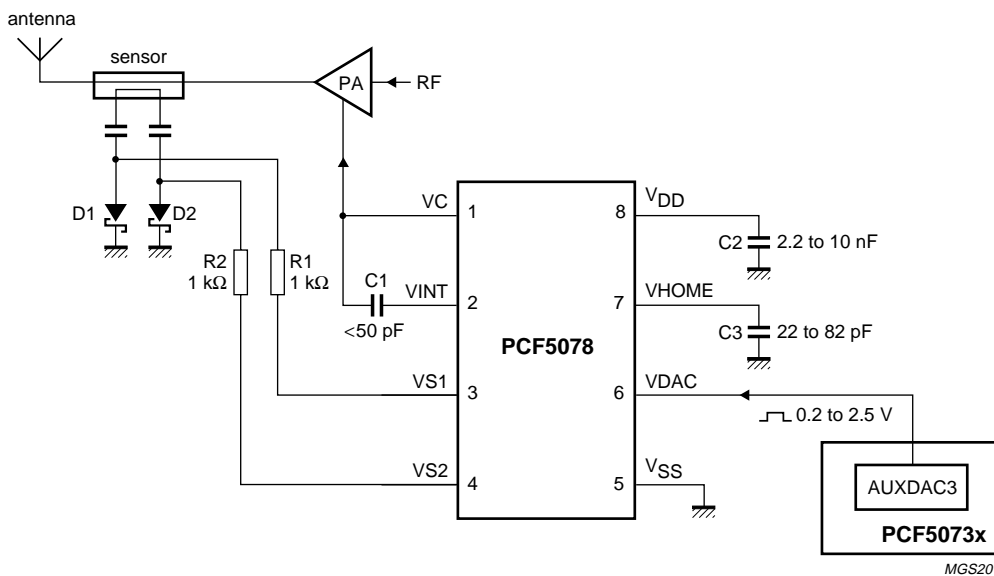
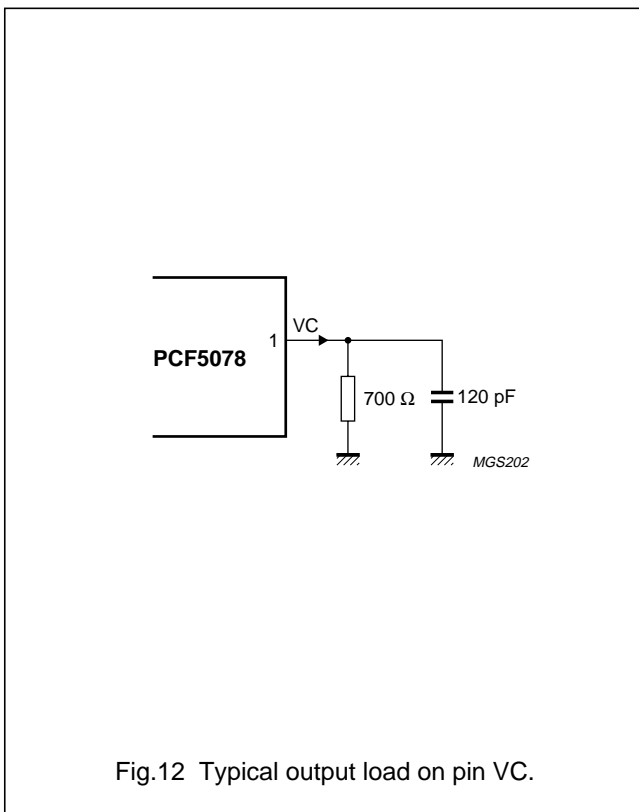
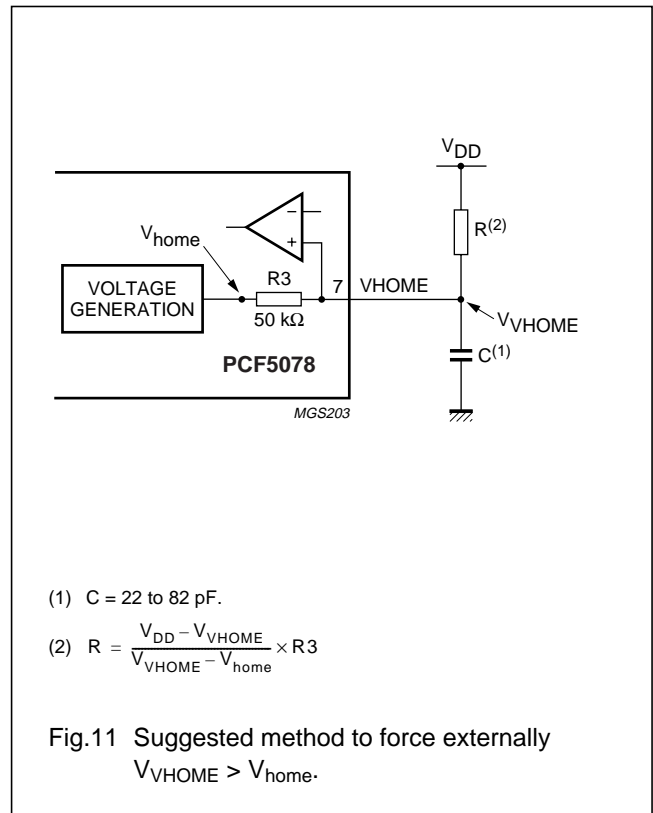
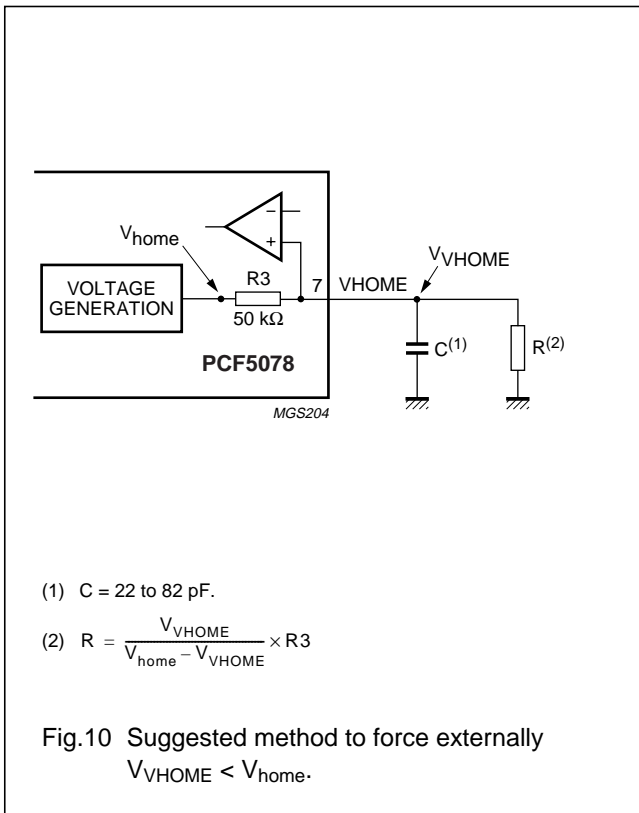

Fig.9 Application diagram for mobile station with PA protection against mismatching.

Power amplifier controller for GSM and PCN systems

PCF5078



Power amplifier controller for GSM and PCN systems

PCF5078

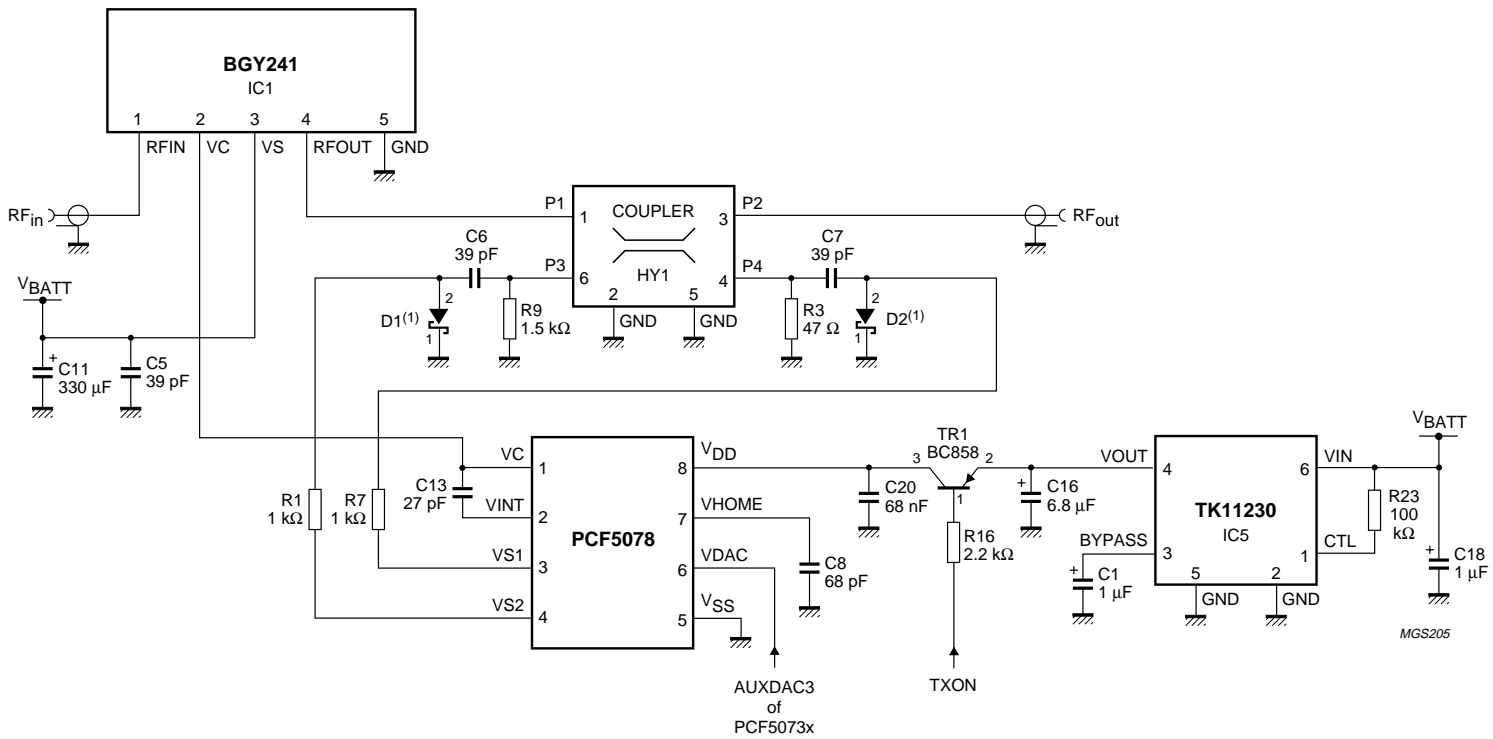

(1) D1 and D2: type BAT62\_03W

Fig.13 Application example of PCF5078.

Power amplifier controller for GSM and PCN systems

PCF5078

PACKAGE OUTLINE

TSSOP8: plastic thin shrink small outline package; 8 leads; body width 3 mm

SOT505-1

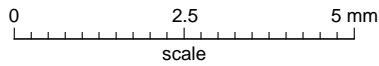
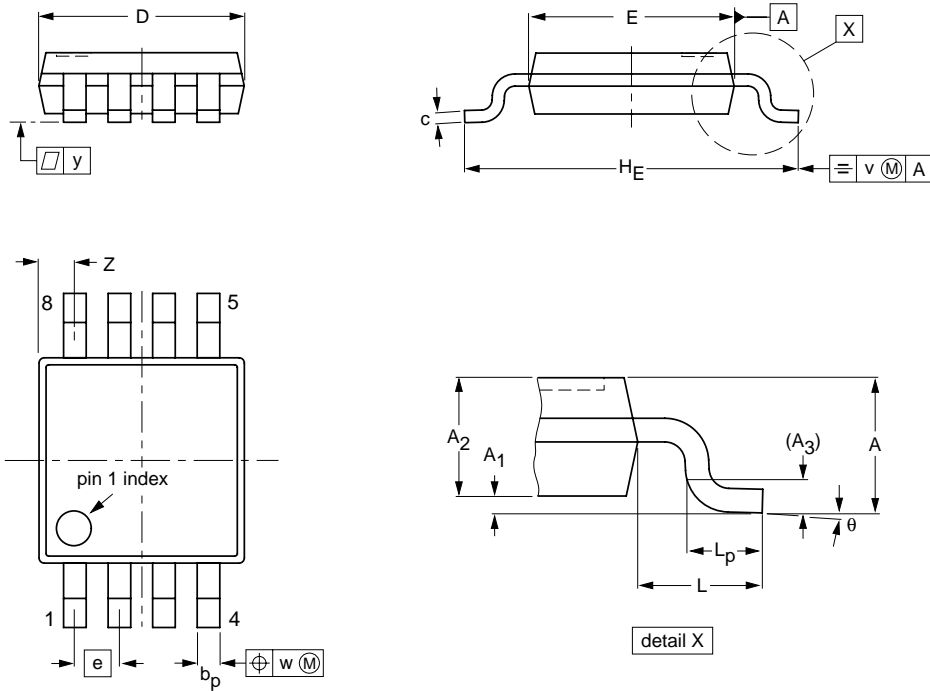

DIMENSIONS (mm are the original dimensions)

UNIT	A max.	A <sub>1</sub>	A <sub>2</sub>	A <sub>3</sub>	b <sub>p</sub>	c	D <sup>(1)</sup>	E <sup>(2)</sup>	e	H <sub>E</sub>	L	L <sub>p</sub>	v	w	y	z <sup>(1)</sup>	θ
mm	1.10	0.15 0.05	0.95 0.80	0.25	0.45 0.25	0.28 0.15	3.10 2.90	3.10 2.90	0.65	5.10 4.70	0.94	0.70 0.40	0.1	0.1	0.1	0.70 0.35	6° 0°

Notes

- 1. Plastic or metal protrusions of 0.15 mm maximum per side are not included.
- 2. Plastic or metal protrusions of 0.25 mm maximum per side are not included.

OUTLINE VERSION	REFERENCES				EUROPEAN PROJECTION	ISSUE DATE
	IEC	JEDEC	EIAJ			
SOT505-1						99-04-09

## Power amplifier controller for GSM and PCN systems

PCF5078

### SOLDERING

#### Introduction to soldering surface mount packages

This text gives a very brief insight to a complex technology. A more in-depth account of soldering ICs can be found in our *"Data Handbook IC26; Integrated Circuit Packages"* (document order number 9398 652 90011).

There is no soldering method that is ideal for all surface mount IC packages. Wave soldering is not always suitable for surface mount ICs, or for printed-circuit boards with high population densities. In these situations reflow soldering is often used.

#### Reflow soldering

Reflow soldering requires solder paste (a suspension of fine solder particles, flux and binding agent) to be applied to the printed-circuit board by screen printing, stencilling or pressure-syringe dispensing before package placement.

Several methods exist for reflowing; for example, infrared/convection heating in a conveyor type oven. Throughput times (preheating, soldering and cooling) vary between 100 and 200 seconds depending on heating method.

Typical reflow peak temperatures range from 215 to 250 °C. The top-surface temperature of the packages should preferably be kept below 230 °C.

#### Wave soldering

Conventional single wave soldering is not recommended for surface mount devices (SMDs) or printed-circuit boards with a high component density, as solder bridging and non-wetting can present major problems.

To overcome these problems the double-wave soldering method was specifically developed.

If wave soldering is used the following conditions must be observed for optimal results:

- Use a double-wave soldering method comprising a turbulent wave with high upward pressure followed by a smooth laminar wave.
- For packages with leads on two sides and a pitch (e):
  - larger than or equal to 1.27 mm, the footprint longitudinal axis is **preferred** to be parallel to the transport direction of the printed-circuit board;
  - smaller than 1.27 mm, the footprint longitudinal axis **must** be parallel to the transport direction of the printed-circuit board.

The footprint must incorporate solder thieves at the downstream end.

- For packages with leads on four sides, the footprint must be placed at a 45° angle to the transport direction of the printed-circuit board. The footprint must incorporate solder thieves downstream and at the side corners.

During placement and before soldering, the package must be fixed with a droplet of adhesive. The adhesive can be applied by screen printing, pin transfer or syringe dispensing. The package can be soldered after the adhesive is cured.

Typical dwell time is 4 seconds at 250 °C.

A mildly-activated flux will eliminate the need for removal of corrosive residues in most applications.

#### Manual soldering

Fix the component by first soldering two diagonally-opposite end leads. Use a low voltage (24 V or less) soldering iron applied to the flat part of the lead. Contact time must be limited to 10 seconds at up to 300 °C.

When using a dedicated tool, all other leads can be soldered in one operation within 2 to 5 seconds between 270 and 320 °C.

# Power amplifier controller for GSM and PCN systems

PCF5078

## Suitability of surface mount IC packages for wave and reflow soldering methods

PACKAGE	SOLDERING METHOD	
	WAVE	REFLOW <sup>(1)</sup>
BGA, SQFP	not suitable	suitable
HLQFP, HSQFP, HSOP, HTSSOP, SMS	not suitable <sup>(2)</sup>	suitable
PLCC <sup>(3)</sup> , SO, SOJ	suitable	suitable
LQFP, QFP, TQFP	not recommended <sup>(3)(4)</sup>	suitable
SSOP, TSSOP, VSO	not recommended <sup>(5)</sup>	suitable

### Notes

- All surface mount (SMD) packages are moisture sensitive. Depending upon the moisture content, the maximum temperature (with respect to time) and body size of the package, there is a risk that internal or external package cracks may occur due to vaporization of the moisture in them (the so called popcorn effect). For details, refer to the Drypack information in the "Data Handbook IC26; Integrated Circuit Packages; Section: Packing Methods".
- These packages are not suitable for wave soldering as a solder joint between the printed-circuit board and heatsink (at bottom version) can not be achieved, and as solder may stick to the heatsink (on top version).
- If wave soldering is considered, then the package must be placed at a 45° angle to the solder wave direction. The package footprint must incorporate solder thieves downstream and at the side corners.
- Wave soldering is only suitable for LQFP, TQFP and QFP packages with a pitch (e) equal to or larger than 0.8 mm; it is definitely not suitable for packages with a pitch (e) equal to or smaller than 0.65 mm.
- Wave soldering is only suitable for SSOP and TSSOP packages with a pitch (e) equal to or larger than 0.65 mm; it is definitely not suitable for packages with a pitch (e) equal to or smaller than 0.5 mm.

### DEFINITIONS

Data sheet status	
Objective specification	This data sheet contains target or goal specifications for product development.
Preliminary specification	This data sheet contains preliminary data; supplementary data may be published later.
Product specification	This data sheet contains final product specifications.
Limiting values	
Limiting values given are in accordance with the Absolute Maximum Rating System (IEC 134). Stress above one or more of the limiting values may cause permanent damage to the device. These are stress ratings only and operation of the device at these or at any other conditions above those given in the Characteristics sections of the specification is not implied. Exposure to limiting values for extended periods may affect device reliability.	
Application information	
Where application information is given, it is advisory and does not form part of the specification.	

### LIFE SUPPORT APPLICATIONS

These products are not designed for use in life support appliances, devices, or systems where malfunction of these products can reasonably be expected to result in personal injury. Philips customers using or selling these products for use in such applications do so at their own risk and agree to fully indemnify Philips for any damages resulting from such improper use or sale.



---

Power amplifier controller for GSM and  
PCN systems

---

PCF5078

**NOTES**

---

Power amplifier controller for GSM and  
PCN systems

---

PCF5078

**NOTES**

---

Power amplifier controller for GSM and  
PCN systems

---

PCF5078

**NOTES**

# Philips Semiconductors – a worldwide company

**Argentina:** see South America

**Australia:** 34 Waterloo Road, NORTH RYDE, NSW 2113,  
Tel. +61 2 9805 4455, Fax. +61 2 9805 4466

**Austria:** Computerstr. 6, A-1101 WIEN, P.O. Box 213,  
Tel. +43 1 60 101 1248, Fax. +43 1 60 101 1210

**Belarus:** Hotel Minsk Business Center, Bld. 3, r. 1211, Volodarski Str. 6,  
220050 MINSK, Tel. +375 172 20 0733, Fax. +375 172 20 0773

**Belgium:** see The Netherlands

**Brazil:** see South America

**Bulgaria:** Philips Bulgaria Ltd., Energoproject, 15th floor,  
51 James Bourchier Blvd., 1407 SOFIA,  
Tel. +359 2 68 9211, Fax. +359 2 68 9102

**Canada:** PHILIPS SEMICONDUCTORS/COMPONENTS,  
Tel. +1 800 234 7381, Fax. +1 800 943 0087

**China/Hong Kong:** 501 Hong Kong Industrial Technology Centre,  
72 Tat Chee Avenue, Kowloon Tong, HONG KONG,  
Tel. +852 2319 7888, Fax. +852 2319 7700

**Colombia:** see South America

**Czech Republic:** see Austria

**Denmark:** Sydhavnsgade 23, 1780 COPENHAGEN V,  
Tel. +45 33 29 3333, Fax. +45 33 29 3905

**Finland:** Sinikalliontie 3, FIN-02630 ESPOO,  
Tel. +358 9 615 800, Fax. +358 9 6158 0920

**France:** 51 Rue Carnot, BP317, 92156 SURESNES Cedex,  
Tel. +33 1 4099 6161, Fax. +33 1 4099 6427

**Germany:** Hammerbrookstraße 69, D-20097 HAMBURG,  
Tel. +49 40 2353 60, Fax. +49 40 2353 6300

**Hungary:** see Austria

**India:** Philips INDIA Ltd, Band Box Building, 2nd floor,  
254-D, Dr. Annie Besant Road, Worli, MUMBAI 400 025,  
Tel. +91 22 493 8541, Fax. +91 22 493 0966

**Indonesia:** PT Philips Development Corporation, Semiconductors Division,  
Gedung Philips, Jl. Buncit Raya Kav.99-100, JAKARTA 12510,  
Tel. +62 21 794 0040 ext. 2501, Fax. +62 21 794 0080

**Ireland:** Newstead, Clonskeagh, DUBLIN 14,  
Tel. +353 1 7640 000, Fax. +353 1 7640 200

**Israel:** RAPAC Electronics, 7 Kehilat Saloniki St, PO Box 18053,  
TEL AVIV 61180, Tel. +972 3 645 0444, Fax. +972 3 649 1007

**Italy:** PHILIPS SEMICONDUCTORS, Piazza IV Novembre 3,  
20124 MILANO, Tel. +39 2 6752 2531, Fax. +39 2 6752 2557

**Japan:** Philips Bldg 13-37, Kohnan 2-chome, Minato-ku,  
TOKYO 108-8507, Tel. +81 3 3740 5130, Fax. +81 3 3740 5077

**Korea:** Philips House, 260-199 Itaewon-dong, Yongsan-ku, SEOUL,  
Tel. +82 2 709 1412, Fax. +82 2 709 1415

**Malaysia:** No. 76 Jalan Universiti, 46200 PETALING JAYA, SELANGOR,  
Tel. +60 3 750 5214, Fax. +60 3 757 4880

**Mexico:** 5900 Gateway East, Suite 200, EL PASO, TEXAS 79905,  
Tel. +9-5 800 234 7381, Fax +9-5 800 943 0087

**Middle East:** see Italy

**Netherlands:** Postbus 90050, 5600 PB EINDHOVEN, Bldg. VB,  
Tel. +31 40 27 82785, Fax. +31 40 27 88399

**New Zealand:** 2 Wagener Place, C.P.O. Box 1041, AUCKLAND,  
Tel. +64 9 849 4160, Fax. +64 9 849 7811

**Norway:** Box 1, Manglerud 0612, OSLO,  
Tel. +47 22 74 8000, Fax. +47 22 74 8341

**Pakistan:** see Singapore

**Philippines:** Philips Semiconductors Philippines Inc.,  
106 Valero St. Salcedo Village, P.O. Box 2108 MCC, MAKATI,  
Metro MANILA, Tel. +63 2 816 6380, Fax. +63 2 817 3474

**Poland:** Ul. Lukiska 10, PL 04-123 WARSZAWA,  
Tel. +48 22 612 2831, Fax. +48 22 612 2327

**Portugal:** see Spain

**Romania:** see Italy

**Russia:** Philips Russia, Ul. Usatcheva 35A, 119048 MOSCOW,  
Tel. +7 095 755 6918, Fax. +7 095 755 6919

**Singapore:** Lorong 1, Toa Payoh, SINGAPORE 319762,  
Tel. +65 350 2538, Fax. +65 251 6500

**Slovakia:** see Austria

**Slovenia:** see Italy

**South Africa:** S.A. PHILIPS Pty Ltd., 195-215 Main Road Martindale,  
2092 JOHANNESBURG, P.O. Box 7430 Johannesburg 2000,  
Tel. +27 11 470 5911, Fax. +27 11 470 5494

**South America:** Al. Vicente Pinzon, 173, 6th floor,  
04547-130 SÃO PAULO, SP, Brazil,  
Tel. +55 11 821 2333, Fax. +55 11 821 2382

**Spain:** Balmes 22, 08007 BARCELONA,  
Tel. +34 93 301 6312, Fax. +34 93 301 4107

**Sweden:** Kottbygatan 7, Akalla, S-16485 STOCKHOLM,  
Tel. +46 8 5985 2000, Fax. +46 8 5985 2745

**Switzerland:** Allmendstrasse 140, CH-8027 ZÜRICH,  
Tel. +41 1 488 2741 Fax. +41 1 488 3263

**Taiwan:** Philips Semiconductors, 6F, No. 96, Chien Kuo N. Rd., Sec. 1,  
TAIPEI, Taiwan Tel. +886 2 2134 2886, Fax. +886 2 2134 2874

**Thailand:** PHILIPS ELECTRONICS (THAILAND) Ltd.,  
209/2 Sanpavuth-Bangna Road Prakanong, BANGKOK 10260,  
Tel. +66 2 745 4090, Fax. +66 2 398 0793

**Turkey:** Talatpasa Cad. No. 5, 80640 GÜLTEPE/ISTANBUL,  
Tel. +90 212 279 2770, Fax. +90 212 282 6707

**Ukraine:** PHILIPS UKRAINE, 4 Patrice Lumumba str., Building B, Floor 7,  
252042 KIEV, Tel. +380 44 264 2776, Fax. +380 44 268 0461

**United Kingdom:** Philips Semiconductors Ltd., 276 Bath Road, Hayes,  
MIDDLESEX UB3 5BX, Tel. +44 181 730 5000, Fax. +44 181 754 8421

**United States:** 811 East Arques Avenue, SUNNYVALE, CA 94088-3409,  
Tel. +1 800 234 7381, Fax. +1 800 943 0087

**Uruguay:** see South America

**Vietnam:** see Singapore

**Yugoslavia:** PHILIPS, Trg N. Pasica 5/v, 11000 BEOGRAD,  
Tel. +381 11 62 5344, Fax. +381 11 63 5777

**For all other countries apply to:** Philips Semiconductors,  
International Marketing & Sales Communications, Building BE-p, P.O. Box 218,  
5600 MD EINDHOVEN, The Netherlands, Fax. +31 40 27 24825

**Internet:** <http://www.semiconductors.philips.com>

© Philips Electronics N.V. 1999

SCA63

All rights are reserved. Reproduction in whole or in part is prohibited without the prior written consent of the copyright owner.

The information presented in this document does not form part of any quotation or contract, is believed to be accurate and reliable and may be changed without notice. No liability will be accepted by the publisher for any consequence of its use. Publication thereof does not convey nor imply any license under patent- or other industrial or intellectual property rights.

Printed in The Netherlands

465008/00/01/pp20

Date of release: 1999 Apr 12

Document order number: 9397 750 04997

*Let's make things better.*

**Philips  
Semiconductors**



**PHILIPS**