

**SOT1NY™ 1-Ohm, Low-Voltage
Single-Supply SPDT Switch**
Features

- Low On-Resistance: 1-ohm max (+5V Supply)
2-ohm max (+3V Supply)
- R_{ON} Matching: 0.12-ohms max. at 25 °C
- R_{ON} Flatness: 0.12-ohms max. (+5V Supply) at 25 °C
- Low 4nA Input Leakage at 25 °C
- +1.8V to +5.5V Single-Supply Operation
- Fast Switching Time (PI5A4624)
 - 50ns t_{ON}
 - 50ns t_{OFF}
- Break-Before-Make Switching Guaranteed (PI5A4624)
- -57dB Off-Isolation at 1MHz
- TTL/CMOS Logic Compatible
- Low Power Consumption: 5 μ W
- Improved Direct Replacement for MAX4624
- Packaging (Pb-free & Green available):
 - 6-pin Small Compact SOT23 (T)

Applications

- Communication Circuits
- Cellular Phones
- Audio and Video Signal Routing
- Portable Battery-Operated Equipment
- Data Acquisition Systems
- Computer Peripherals
- Telecommunications
- Relay Replacement
- Wireless Terminals and Peripherals
- Hard Drives
- Modems

Description

The PI5A4624 is an improved, direct replacement for the MAX4624 single-pole, double-throw (SPDT) analog switch. Improved specifications include a low maximum On-resistance of 1-ohm and fast switching times ($t_{ON} = 50\text{ns max.}$, $t_{OFF} = 50\text{ns max.}$) with 5V supply operation. With a 2.5V supply, resistance is a low 4-ohm max.

Specifications are given for 1.8V, 2.5V, 3.3V and 5V power supply operation. Operating voltage range is +1.8V to +5.5V.

To minimize PC board area use, the PI5A4624 is available in a compact 6-pin SOT23 package.

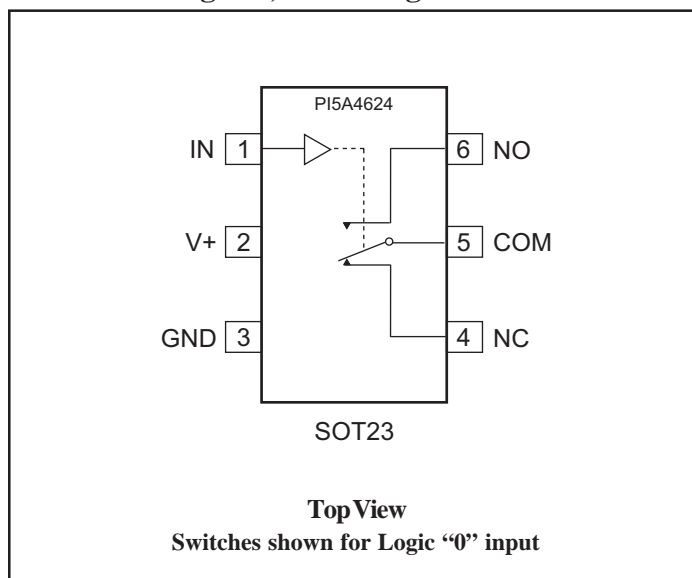
Functional Diagram, Pin Configuration

Truth Table

Logic	PI5A4624	
	NC	NO
0	ON	OFF
1	OFF	ON

Absolute Maximum Ratings

Voltages Referenced to GND

V₊ -0.5V to +5.5V

V_{IN}, V_{COM}, V_{NC}, V_{NO} (Note 1) -0.5V to V₊+0.3V
 or 30mA, whichever occurs first

Current (any terminal) ±200mA

Peak Current, COM, NO, NC

(Pulsed at 1ms, 10% duty cycle) ±400mA

Thermal Information

Continuous Power Dissipation

SOT23-6 (derate 7.1mW/°C above +70°C) 0.5W

Storage Temperature -65°C to +150°C

Lead Temperature (soldering, 10s) +300°C

Note:

1. Signals on NC, NO, COM, or IN exceeding V₊ or GND are clamped by internal diodes. Limit forward diode current to 30mA.

Caution: Stresses beyond those listed under “Absolute Maximum Ratings” may cause permanent damage to the device. This is a stress only rating and operation of the device at these or any other conditions beyond those indicated in the operational sections of this specification is not implied.

Electrical Specifications - Single +5V Supply

(V₊ = +5V ± 10%, GND = 0V, V_{INH} = 2.4V, V_{INL} = 0.8V, T_A = -40°C to 85°C)

Parameter	Symbol	Conditions	Temp. (°C)	Min. ⁽¹⁾	Typ. ⁽²⁾	Max. ⁽¹⁾	Units	
Analog Switch								
Analog Signal Range ⁽³⁾	V _{ANALOG}		Full	0		V ₊	V	
On Resistance	R _{ON}	V ₊ = 4.5V, I _{COM} = -30mA, V _{NO} or V _{NC} = +2.5V	25		0.70	0.90	ohm	
			Full			1.1		
On-Resistance Match Between Channels ⁽⁴⁾	ΔR _{ON}		25		0.03	0.05		
			Full			0.10		
On-Resistance Flatness ⁽⁵⁾	R _{FLAT(ON)}	V ₊ = 4.5V, I _{COM} = -30mA, V _{NO} or V _{NC} = 0V, 1.5V, 2.5V	25		0.08	0.12		
			Full			0.15		
NO or NC Off Leakage Current ⁽⁶⁾	I _{NO(OFF)} or I _{NC(OFF)}		V ₊ = 5.5V, V _{COM} = 0V V _{NO} or V _{NC} = 4.5V	25	2	0.01	2	nA
				Full	-20		20	
COM On Leakage Current ⁽⁶⁾	I _{COM(ON)}	V ₊ = 5.5V, V _{COM} = +4.5V V _{NO} or V _{NC} = +4.5V		25	-4		4	
				Full	-40	0.3	40	

Electrical Specifications - Single +5V Supply (continued)

(V₊ = +5V ± 10%, GND = 0V, V_{INH} = 2.4V, V_{INL} = 0.8V)

Parameter	Symbol	Conditions	Temp. (°C)	Min. ⁽¹⁾	Typ. ⁽²⁾	Max. ⁽¹⁾	Units
Analog Switch							
Input High Voltage	V _{IH}	Guaranteed Logic High Level	Full	2.4			V
Input Low Voltage	V _{IL}	Guaranteed Logic LowLevel				0.8	
Input Current with Voltage High	I _{INH}	V _{IN} = 2.4V, all others = 0.8V		-1	0.005	1	μA
Input Current with Voltage Low	I _{INL}	V _{IN} = 0.8V, all others = 2.4V		-1	0.005	1	
Dynamic							
Turn-On-Time	t _{ON}	V _{CC} = 5V, Figure 1	25		20	35	ns
			Full			40	
Turn-Off-Time	t _{OFF}		25		15	20	
			Full			35	
Break-Before-Make	t _{BBM}	Figure 3 (PI5A4624 Only)	25	1	12	14.5	
			Full	1	17.5		
Make-Before-Break	t _{MBB}	Figure 4 (PI5A4625 Only)	25	1	14	17	
			Full	1	20.5		
Charge Injection ⁽³⁾	Q	C _L = 1nF, V _{GEN} = 0V, R _{GEN} = 0-ohm, Figure 2	25		40		pC
Off Isolation	OIRR	R _L = 50-ohms, f = 1MHz, Figure 5			-57		dB
CrossTalk ⁽⁸⁾	X _{TALK}	R _L = 50-ohms, f = 1MHz, Figure 6			-57		
NC or NO Capacitance	C _{NC/NO(OFF)}	f = 1MHz, Figure 7			42		pF
COM Off Capacitance	C _{COM(OFF)}				83		
COM On Capacitance	C _{COM(ON)}		f = 1MHz, Figure 8			130	
Supply							
Power-Supply Range	V+		Full	1.8		5.5	V
Positive Supply Current	I+	V _{CC} = 5.5V, V _{IN} = 0V or V+			0.5		1

Notes:

1. The algebraic convention, where most negative value is a minimum and most positive is a maximum, is used in this data sheet.
2. Typical values are for DESIGN AID ONLY, not guaranteed or subject to production testing.
3. Guaranteed by design.
4. ΔRON = RON max. - RON min.
5. Flatness is defined as the difference between the maximum and minimum value of On-resistance measured.
6. Leakage parameters are 100% tested at maximum rated hot temperature and guaranteed by correlation at +25°C.
7. Off Isolation = 20log₁₀ [V_{COM} / (V_{NO} or V_{NC})]. See Figure 5
8. Between any two switches. See Figure 6.

Electrical Specifications - Single +3.3V Supply

(V+ = +3.3V ± 10%, GND = 0V, V_{INH} = 2.0V, V_{INL} = 0.6V)

Parameter	Symbol	Conditions	Temp. (°C)	Min. ⁽¹⁾	Typ. ⁽²⁾	Max. ⁽¹⁾	Units
Analog Switch							
Analog Signal Range ⁽³⁾	V _{ANALOG}			0		V+	V
On-Resistance	R _{ON}	V+ = 3V, I _{COM} = -24mA V _{NO} or V _{NC} = 2.0V	25		1.4	1.8	ohm
			Full			2.2	
On-Resistance Match Between Channels ⁽⁴⁾	ΔR _{ON}	V+ = 3.3V, I _{COM} = -24mA V _{NO} or V _{NC} = 0.8V, 2.0V	25		0.04	0.05	
			Full		0.11		
On-Resistance Flatness	R _{FLAT(ON)}	V+ = 3.3V, I _{COM} = -24mA V _{NO} or V _{NC} = 0.8V, 2.0V	25		0.17	0.2	
			Full		0.25		
Dynamic							
Turn-On-Time	t _{ON}	V+ = 3.3V, V _{NO} or V _{NC} = 2.0V, Figure	25		30	40	ns
			Full			55	
Turn-Off-Time	t _{OFF}	V+ = 3.3V, V _{NO} or V _{NC} = 2.0V, Figure	25		20	25	
			Full			40	
Break-Before-Make	t _{BBM}	Figure 3 (PI5A4624 Only)	25	1	21	29	
Make-Break-Before	t _{MBB}	Figure 4 (PI5A4625 Only)	25	1	13	17.5	
Charge Injection ⁽³⁾	Q	C _L - 1nF, V _{GEN} = 0V, R _{GEN} = 0V, Figure 2	25		30		pC
Supply							
Positive Supply Current	I+	V+ = 3.6V, V _{IN} = 0V or V+ All Channels on or off	Full		0.5	1	μA
Logic Input							
Input High Voltage	V _{IH}	Guaranteed Logic High Level	Full	2			V
Input Low Voltage	V _{IL}	Guaranteed Logic LowLevel	Full			0.6	
Input High Current	I _{INH}	V _{IN} = 2.4V, all others = 0.8V	Full	-1		1	μA
Input Low Current	I _{INL}	V _{IN} = 0.8V, all others = 2.4V	Full	-1		1	

Notes:

1. The algebraic convention, where most negative value is a minimum and most positive is a maximum, is used in this data sheet.
2. Typical values are for DESIGN AID ONLY, not guaranteed or subject to production testing.
3. Guaranteed by design.
4. ΔR_{ON} = R_{ON} max. - R_{ON} min.
5. Flatness is defined as the difference between the maximum and minimum value of On-resistance measured.

Electrical Specifications - Single +2.5V Supply

(V+ = +2.5V ± 10%, GND = 0V, V_{INH} = 1.8V, V_{INL} = 0.6V)

Parameter	Symbol	Conditions	Temp. (°C)	Min. ⁽¹⁾	Typ. ⁽²⁾	Max. ⁽¹⁾	Units
Analog Switch							
Analog Signal Range ⁽³⁾	V _{ANALOG}			0		V+	V
On-Resistance	R _{ON}	V+ = 2.5V, I _{COM} = -8mA V _{NO} or V _{NC} = 1.8V	25		1.6	2	Ohm
			Full			2.7	
On-Resistance Match Between Channels ⁽⁴⁾	ΔR _{ON}	V+ = 2.5V, I _{COM} = -8mA V _{NO} or V _{NC} = 0.8V, 1.8V	25		0.13	0.16	
			Full		0.2		
On-Resistance Flatness	R _{FLAT(ON)}	V+ = 2.5V, I _{COM} = -8mA V _{NO} or V _{NC} = 0.8V, 1.8V	25		0.25	0.3	
			Full		0.45		
Dynamic							
Turn-On-Time	t _{ON}	V+ = 2.5V, V _{NO} or V _{NC} = 1.8V, Figure 1	25		40	55	ns
			Full			70	
Turn-Off-Time	t _{OFF}	V+ = 2.5V, V _{NO} or V _{NC} = 1.8V, Figure 1	25		30	40	
			Full			55	
Break-Before-Make	t _{BBM}	Figure 3 PI5A4624 Only)	25	1	33	39	
Make-Break-Before	t _{MBB}	Figure 4 PI5A4625 Only)	25	1	9	13	
Charge Injection ⁽³⁾	Q	C _L - 1nF, V _{GEN} = 0V, R _{GEN} = 0V, Figure 2	25		20		pC
Supply							
Positive Supply Current	I+	V+ = 2.75V, V _{IN} = 0V or V+ All Channels on or off	Full		0.5	1	μA
Logic Input							
Input High Voltage	V _{IH}	Guaranteed Logic High Level	Full	1.8			V
Input Low Voltage	V _{IL}	Guaranteed Logic LowLevel	Full			0.6	
Input High Current	I _{INH}	V _{IN} = 2.0V, all others = 0.8V	Full	-1		1	μA
Input Low Current	I _{INL}	V _{IN} = 0.8V, all others = 2.0V	Full	-1		1	

Notes:

1. The algebraic convention, where most negative value is a minimum and most positive is a maximum, is used in this data sheet.
2. Typical values are for DESIGN AID ONLY, not guaranteed or subject to production testing.
3. Guaranteed by design.
4. ΔR_{ON} = R_{ON} max. - R_{ON} min.
5. Flatness is defined as the difference between the maximum and minimum value of On-resistance measured.

Electrical Specifications - Single +1.8V Supply

(V+ = +1.8V ± 10%, GND = 0V, V_{INH} = 1.5V, V_{INL} = 0.6V)

Parameter	Symbol	Conditions	Temp. (°C)	Min. ⁽¹⁾	Typ. ⁽²⁾	Max. ⁽¹⁾	Units
Analog Switch							
Analog Signal Range ⁽³⁾	V _{ANALOG}			0		V+	V
On-Resistance	R _{ON}	V+ = 1.8V, I _{COM} = -2mA V _{NO} or V _{NC} = 1.5V	25		2.8	4	Ohm
			Full			5	
On-Resistance Match Between Channels ⁽⁴⁾	ΔR _{ON}	V+ = 1.8V, I _{COM} = -2mA V _{NO} or V _{NC} = 0.6V, 1.5V	25		0.44	0.6	
			Full		0.7		
On-Resistance Flatness	R _{FLAT(ON)}	V+ = 1.8V, I _{COM} = -2mA V _{NO} or V _{NC} = 0.6V, 1.5V	25		0.5	0.6	
			Full		0.9		
Dynamic							
Turn-On-Time	t _{ON}	V+ = 1.8V, V _{NO} or V _{NC} = 1.5V, Figure 1	25		65	70	ns
			Full			95	
Turn-Off-Time	t _{OFF}		25		40	55	
			Full			70	
Break-Before-Make	t _{BBM}	Figure 3 (PI5A4624 Only)	25	1	60	72	
Make-Break-Before	t _{MBB}	Figure 4 (PI5A4625 Only)	25	1	10	14	
Charge Injection ⁽³⁾	Q	C _L = 1nF, V _{GEN} = 0V, R _{GEN} = 0V, Figure 2	25		10		pC
Supply							
Positive Supply Current	I+	V+ = 2.0V, V _{IN} = 0V or V+ All Channels on or off	Full		0.5	1	μA
Logic Input							
Input High Voltage	V _{IH}	Guaranteed Logic High Level	Full	1.8			V
Input Low Voltage	V _{IL}	Guaranteed Logic LowLevel	Full			0.6	
Input High Current	I _{INH}	V _{IN} = 1.5V, all others = 0.8V	Full	-1		1	μA
Input Low Current	I _{INL}	V _{IN} = 0.8V, all others = 1.5V	Full	-1		1	

Notes:

1. The algebraic convention, where most negative value is a minimum and most positive is a maximum, is used in this data sheet.
2. Typical values are for DESIGN AID ONLY, not guaranteed or subject to production testing.
3. Guaranteed by design.
4. ΔR_{ON} = R_{ON} max. - R_{ON} min.
5. Flatness is defined as the difference between the maximum and minimum value of On-resistance measured.

Test Circuits/Timing Diagrams

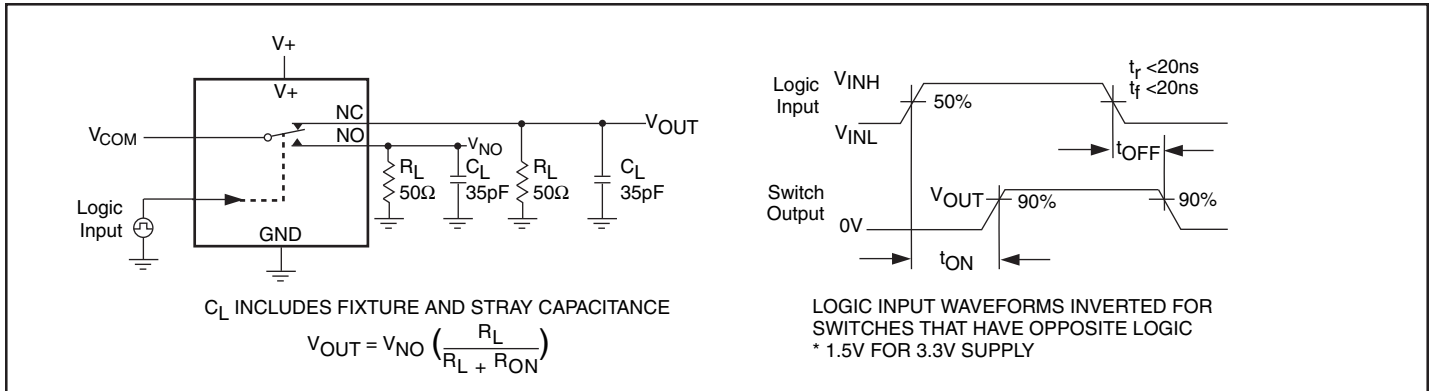

Figure 1. Switching Time

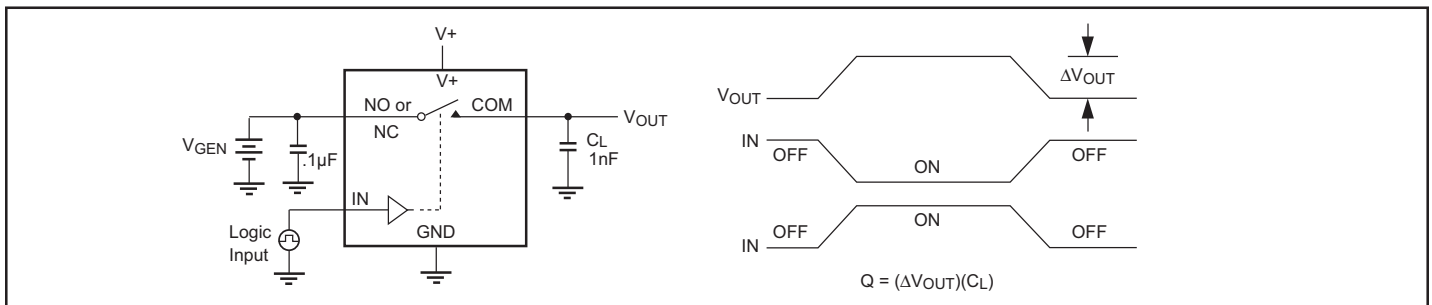

Figure 2. Charge Injection

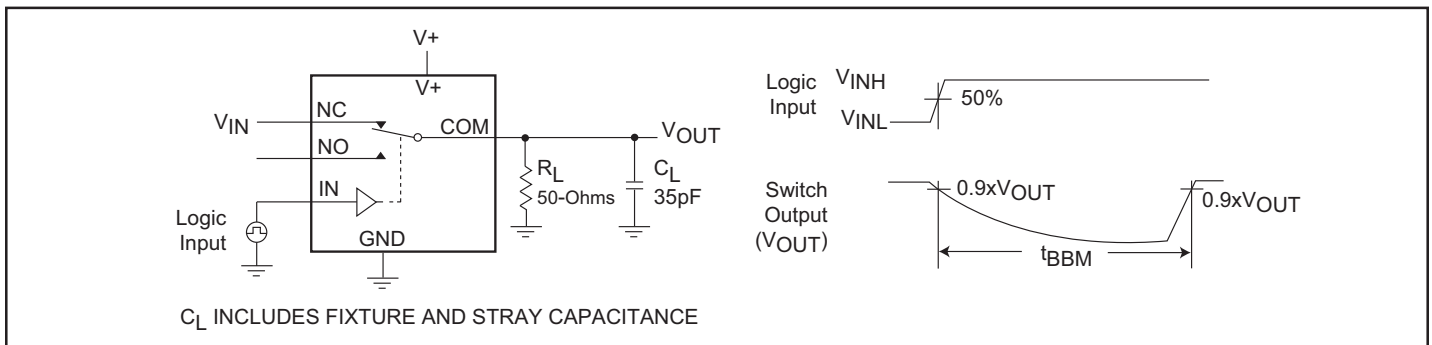

Figure 3. Break-Before-Make Interval (PI5A4624)

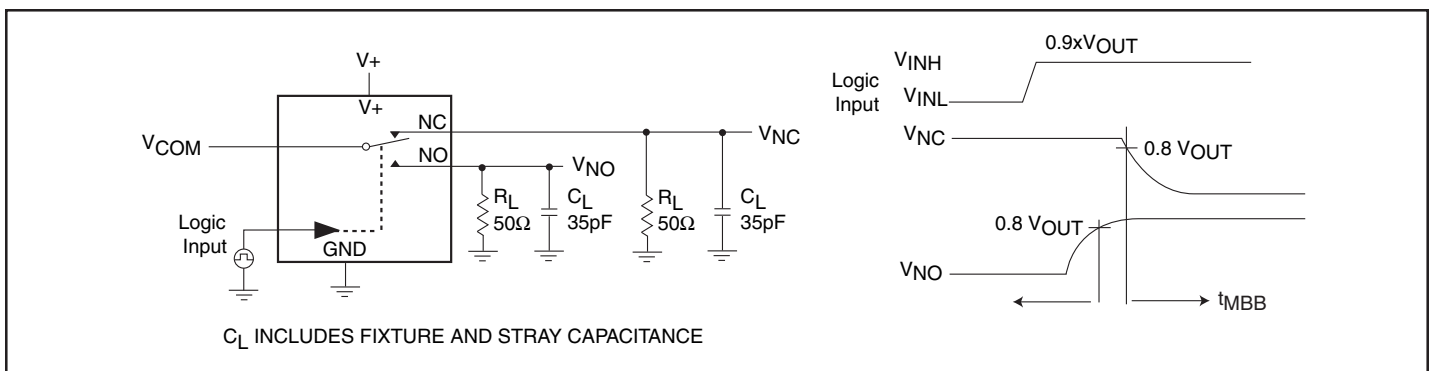

Figure 4. Make-Before-Break Interval (PI5A4625)

Test Circuits/Timing Diagrams (continued)

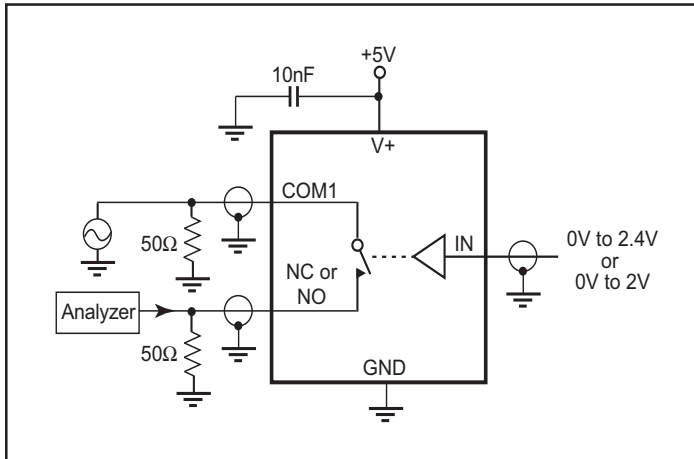

Figure 5. Off Isolation/On-Channel Bandwidth

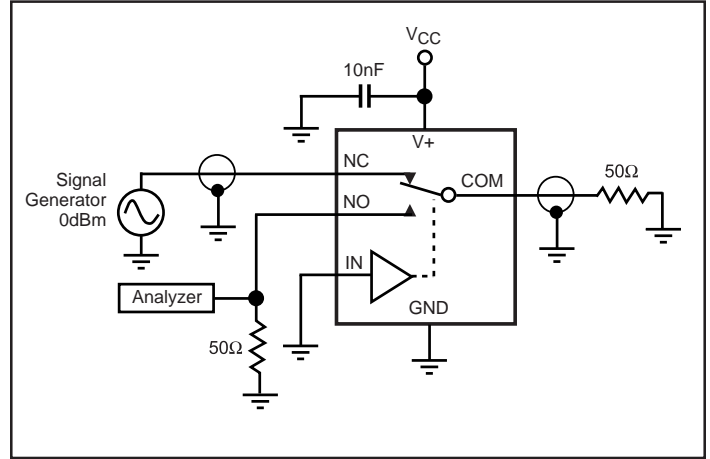

Figure 6. Crosstalk

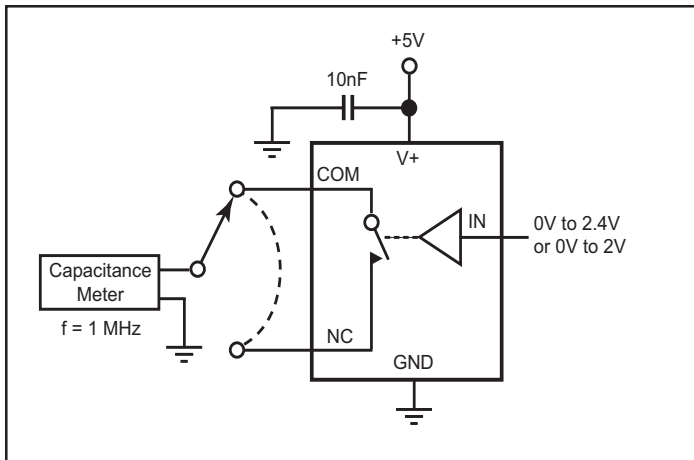

Figure 7. Channel-Off Capacitance

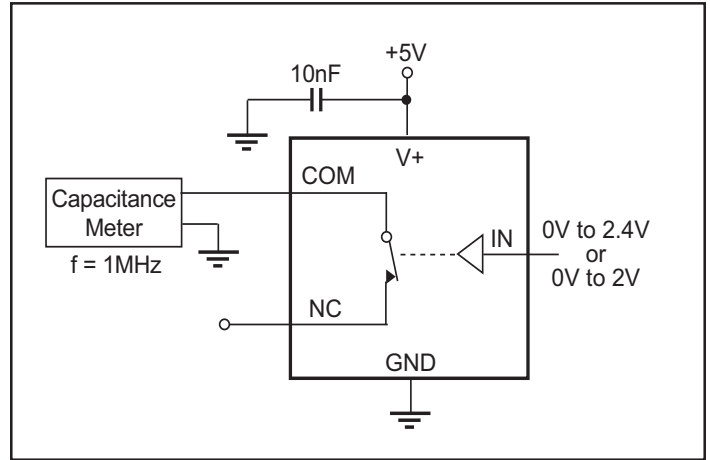

Figure 8. Channel-On Capacitance

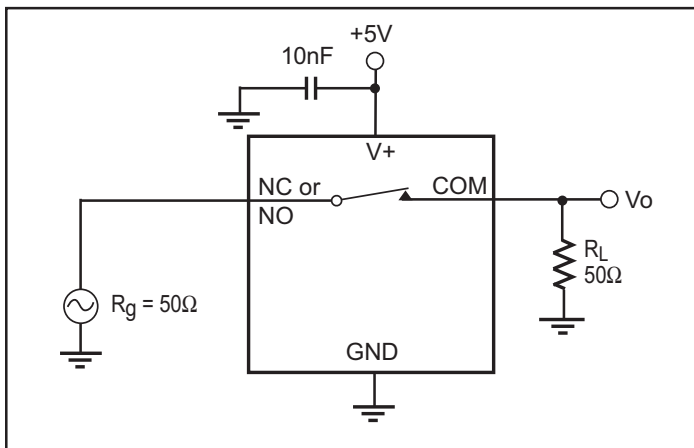
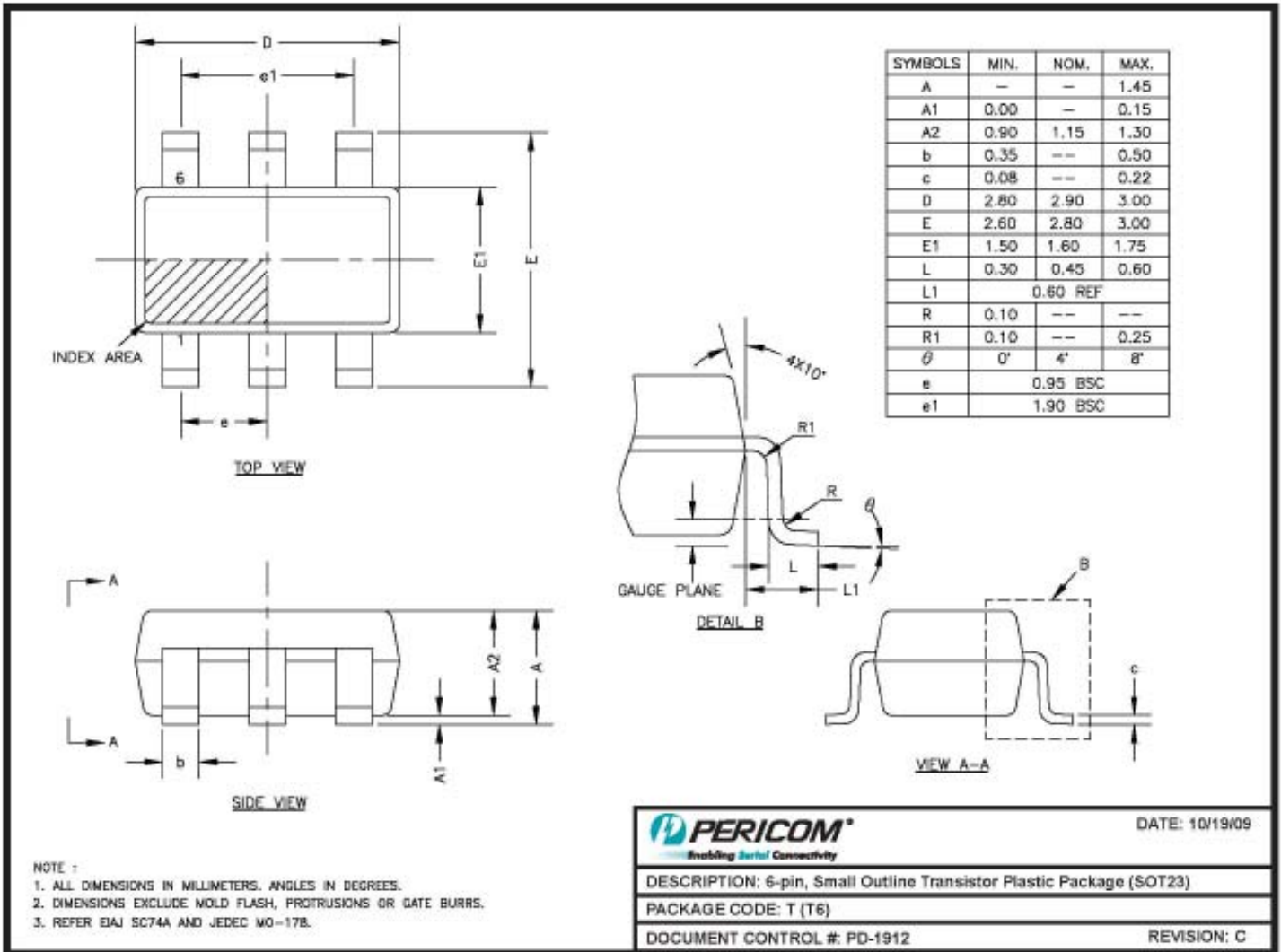

Figure 9. Bandwidth

Packaging Mechanical: 6-Pin SOT23 (T)



09-0131

Ordering Information

Ordering Code	Package Code	Package Description	Top Marking
PI5A4624TEX	T	Pb-free & Green, 6-pin SOT23	ZK

Notes:

1. Thermal Characteristics can be found on the world wide web at www.pericom.com/packaging/
2. Number of transistors : 753 (Both devices)
3. E = Pb-free and Green
4. X suffix = Tape/Reel