

Infinion's IWORX controller is a multi-service engine for wireless access network and media gateway linecards. Designed to transport ATM traffic over PDH and SDH based networks, IWORX enables the adaptation of voice, video and data traffic via AAL2 at speeds up to 155 Mbit/s.

Shared location of 2G and 3G mobile networks for easy network migration path is facilitated via AAL1 and Circuit Emulation Service (CES). The IWORX controller also provides flexible PDH port bandwidth adjustment through four IMA groups, and implements all ATM service categories (CBR, VBR, UBR) for full Quality of Service (QoS) support.

Infinion's IWORX system on a chip with integrated memory and high-level API command interface is also easy to use, making it the most optimized solution in terms of performance, small BOM and power economy.



Applications

- 3G base transceiver stations (Node B) and radio network controller (RNC)
- Multiservice Linecards
- Multimedia Gateways

Features

- Throughput up to 155 Mbit/s
- On-chip CPU for simple protocol handling and control
- Easy to configure with maintenance and in-band communication via message based interface
- Embedded Memory
- Port specific mode selection
- Time slot specific protocol selection such as AAL1 and G.804
- Dedicated hardware modules for fast and reliable performance intensive communication functions such as AAL1, AAL2,

- G.804, OAM, IMA and traffic management
- Highly integrated IC reduces power requirements, BOM and overall costs
- System recovery support by configuration and connection data read-back
- Boundary scan support according to IEEE 1149.1

ATM Adaptation Layer Functions

- Supports up to 256 AAL1 ATM VCCs
- Supports structured and unstructured CES modes for eight E1/T1/J1 links
- Supports Channel Associated Signaling (CAS)
- Built in SRTS (selectable) and ACM clock recovery methods
- Supports AAL2 mode features according to ITU-T I.363.2
- Supports up to 16 AAL2 ATM VCCs

- Mux/demux of up to 255 AAL2 channels per AAL2 ATM VCC
- AAL5 support according to ITU-T I.363-5

ATM Layer Functions

- Address Reduction and Header Translation
- Traffic Management
- Operating and Maintenance according to ITU-T I.610 (99)

TC Sub-layer Functions

- ATM TC sub-layer (ITU-T G.804)
- Support for G.804 on fractional E1/T1/J1 (ATMF-FN64)
- Supports up to 8 HDLC channels for CCS
- IMA8 (ATMF AF-PHY 0086.001)

Physical Characteristics

- Power consumption <2 W
- Power supply 3.3 V I/O, 1.8 V core
- Temperature range -40°C to +85°C

IWORX

ATM Interworking Controller
PXF 4225E



Never stop thinking.

IWORX PXF 4225 E Block Diagram

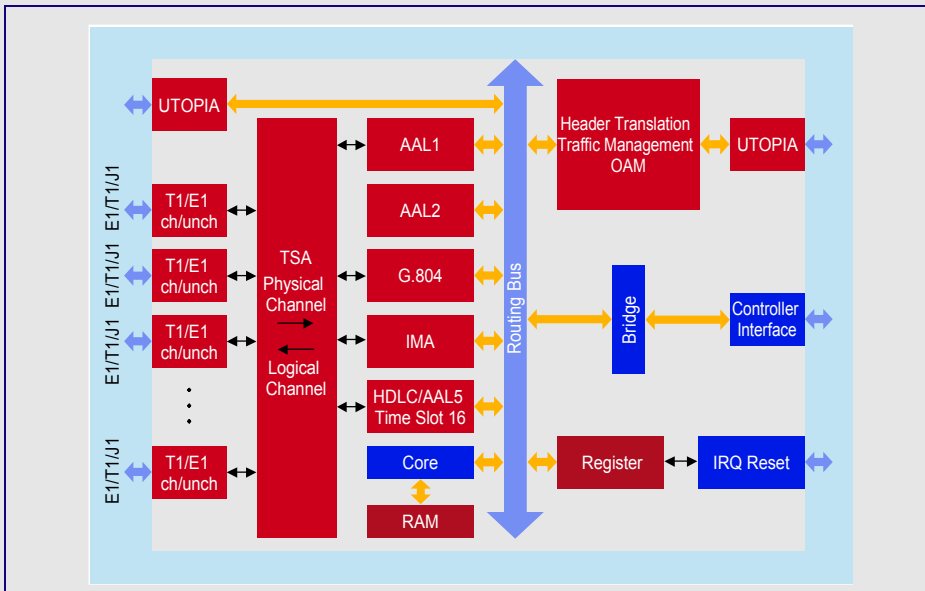

Ordering Information

IC

Product	Sales Code	Package	Description
IWORX	PXF 4225 E	P-BGA-388	ATM Interworking Controller

Design Tools

Product	Sales Code	Package	Description
EASY4225-R2	Easy 4225 R2	Evaluation System	Evaluation board and software support package

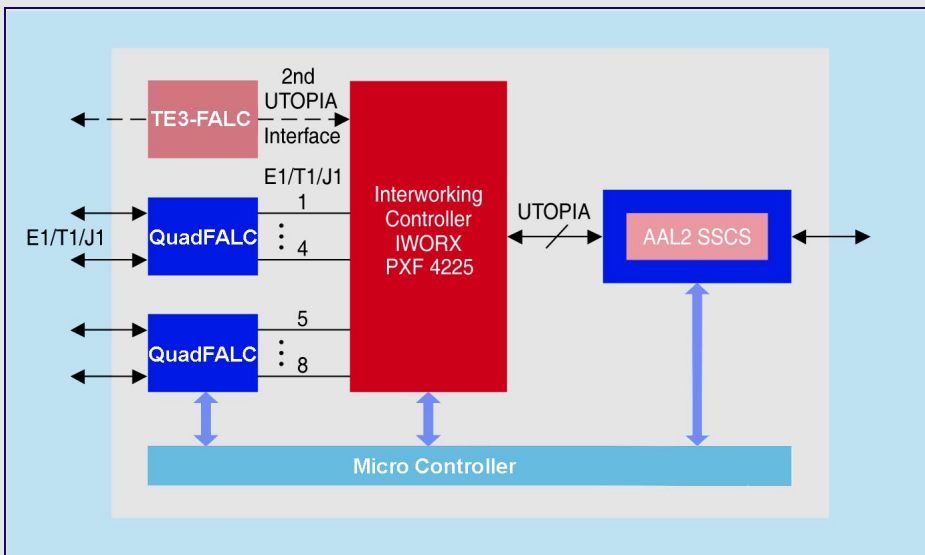

8 x E1/T1/J1 ATM- Linecard Application Example

How to reach us:

<http://www.infineon.com>

Published by
Infineon Technologies AG,
St. Martin-Strasse 53,
D-81669 München

© Infineon Technologies AG 2003. All Rights Reserved.

Attention please!

The information herein is given to describe certain components and shall not be considered as a guarantee of characteristics.

Terms of delivery and rights to technical change reserved.

We hereby disclaim any and all warranties, including but not limited to warranties of non-infringement, regarding circuits, descriptions and charts stated herein.

Information

For further information on technology, delivery terms and conditions and prices please contact your nearest Infineon Technologies Office.

Warnings

Due to technical requirements components may contain dangerous substances. For information on the types in question please contact your nearest Infineon Technologies Office.

Infineon Technologies Components may only be used in life-support devices or systems with the express written approval of Infineon Technologies, if a failure of such components can reasonably be expected to cause the failure of that life-support device or system, or to affect the safety or effectiveness of that device or system. Life support devices or systems are intended to be implanted in the human body, or to support and/or maintain and sustain and/or protect human life. If they fail, it is reasonable to assume that the health of the user or other persons may be endangered.

Template: pb_tmplt.fm/2/2003-05-01