

**SUPER-SMALL PACKAGE HIGH-PRECISION VOLTAGE DETECTOR S-808 Series**

The S-808 Series is a high-precision voltage detector developed using CMOS process. The detection voltage is fixed internally, with an accuracy of  $\pm 2.0\%$ . Two output types, Nch open-drain and CMOS output, are available.

**■ Features**

- ↳ Ultra-low current consumption
  - 1.3  $\mu\text{A}$  typ. ( $V_{DD}=1.5\text{ V}$ )
  - Products with detection voltage of 1.4 V or less electronic
  - 0.8  $\mu\text{A}$  typ. ( $V_{DD}=3.5\text{ V}$ )
  - Products with detection voltage of 1.5 V or more
- ↳ High-precision detection voltage
  - $\pm 2.0\%$
- ↳ Low operating voltage
  - 0.7 to 5.0 V
  - Products with detection voltage of 1.4 V or less
  - 0.95 to 10.0 V
  - Products with a detection voltage of 1.5 V or more
- ↳ Hysteresis characteristics
  - 5% typ.
- ↳ Detection voltage
  - 0.8 to 6.0 V
  - (0.1 V step)
- ↳ Nch open-drain active low and CMOS active low output
- ↳ SC-82AB Super-small plastic package
- ↳ TO-92 Plastic package
- ↳ SOT-89-3 Miniaturized power mold plastic package
- ↳ SOT-23-5 Very-small plastic package

**■ Applications**

- ↳ Battery checker
- ↳ Power failure detector
- ↳ Power monitor for pagers, calculators, organizers,
- ↳ Constant voltage power monitor for cameras, video equipment, communication devices
- ↳ Power monitor for microcomputers and reset CPUs

**■ Pin Assignment**

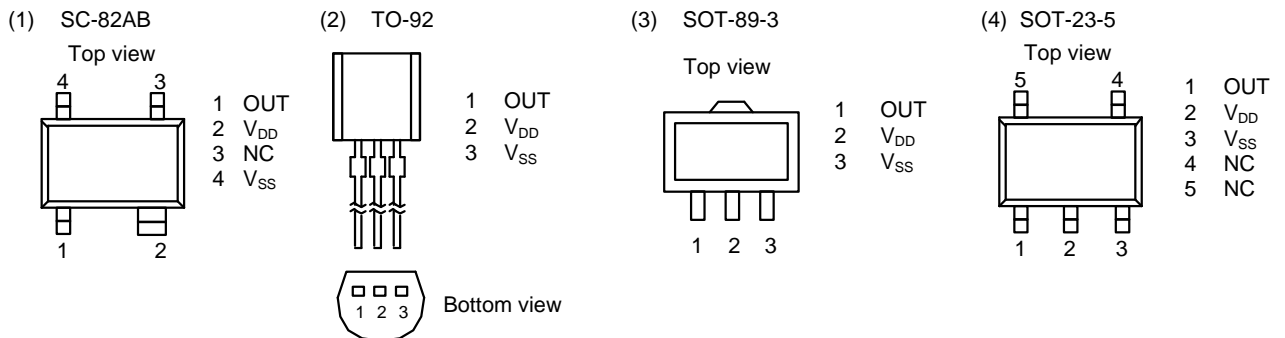

Figure 1

# SUPER-SMALL PACKAGE HIGH-PRECISION VOLTAGE DETECTOR

## S-808 Series

### ■ Block Diagram

(1) Nch open-drain active low output

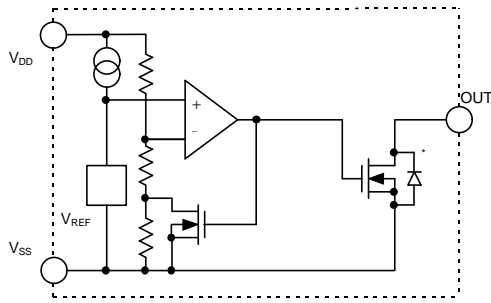

(2) CMOS active low output

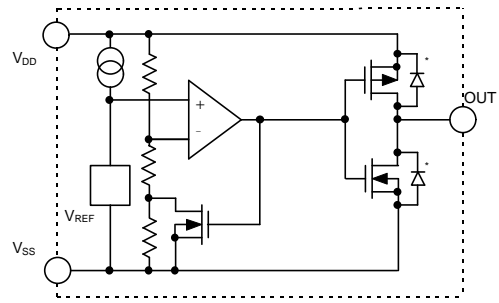

\*Parasitic diode

Figure 2

### ■ Selection Guide

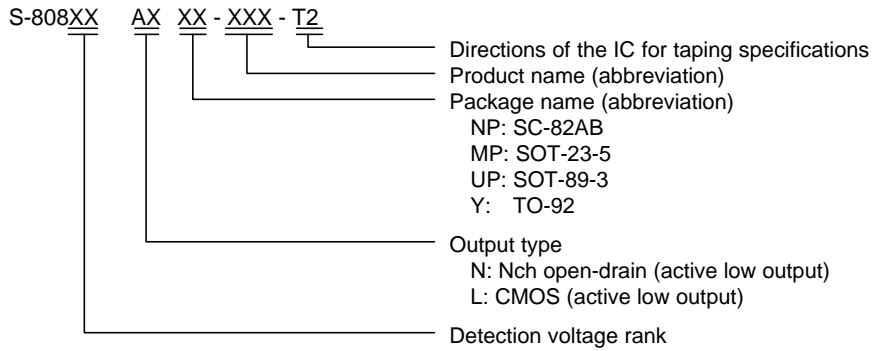

**SUPER-SMALL PACKAGE HIGH-PRECISION VOLTAGE DETECTOR**  
**S-808 Series**

**Table 1**

Detection voltage range (V)	Hysteresis width $V_{HYS}$ typ.(V)	Nch Open Drain(Low)			
		SC-82AB	TO-92	SOT-89-3	SOT-23-5
0.8V±2.0%	0.034	S-80808ANNP-E7Y-T2	—	—	—
0.9V±2.0%	0.044	S-80809ANNP-E7Z-T2	—	—	—
1.0V±2.0%	0.054	S-80810ANNP-E70-T2	—	—	—
1.1V±2.0%	0.064	S-80811ANNP-E71-T2	—	—	—
1.2V±2.0%	0.073	S-80812ANNP-E72-T2	—	—	—
1.3V±2.0%	0.083	S-80813ANNP-EDA-T2	—	—	—
1.4V±2.0%	0.093	S-80814ANNP-EDB-T2	—	—	—
1.5V±2.0%	0.075	S-80815ANNP-EDC-T2	S-80815ANY	S-80815ANUP-EDC-T2	—
1.6V±2.0%	0.080	S-80816ANNP-EDD-T2	S-80816ANY	S-80816ANUP-EDD-T2	—
1.7V±2.0%	0.085	S-80817ANNP-EDE-T2	S-80817ANY	S-80817ANUP-EDE-T2	S-80817ANMP-EDE-T2
1.8V±2.0%	0.090	S-80818ANNP-EDF-T2	S-80818ANY	S-80818ANUP-EDF-T2	S-80818ANMP-EDF-T2
1.9V±2.0%	0.095	S-80819ANNP-EDG-T2	S-80819ANY	S-80819ANUP-EDG-T2	S-80819ANMP-EDG-T2
2.0V±2.0%	0.100	S-80820ANNP-EDH-T2	S-80820ANY	S-80820ANUP-EDH-T2	S-80820ANMP-EDH-T2
2.1V±2.0%	0.105	S-80821ANNP-EDJ-T2	S-80821ANY	S-80821ANUP-EDJ-T2	S-80821ANMP-EDJ-T2
2.2V±2.0%	0.110	S-80822ANNP-EDK-T2	S-80822ANY	S-80822ANUP-EDK-T2	S-80822ANMP-EDK-T2
2.3V±2.0%	0.115	S-80823ANNP-EDL-T2	S-80823ANY	S-80823ANUP-EDL-T2	S-80823ANMP-EDL-T2
2.4V±2.0%	0.120	S-80824ANNP-EDM-T2	S-80824ANY	S-80824ANUP-EDM-T2	S-80824ANMP-EDM-T2
2.5V±2.0%	0.125	S-80825ANNP-EDN-T2	S-80825ANY	S-80825ANUP-EDN-T2	S-80825ANMP-EDN-T2
2.6V±2.0%	0.130	S-80826ANNP-EDP-T2	S-80826ANY	S-80826ANUP-EDP-T2	—
2.7V±2.0%	0.135	S-80827ANNP-EDQ-T2	S-80827ANY	S-80827ANUP-EDQ-T2	S-80827ANMP-EDQ-T2
2.8V±2.0%	0.140	S-80828ANNP-EDR-T2	S-80828ANY	S-80828ANUP-EDR-T2	S-80828ANMP-EDR-T2
2.9V±2.0%	0.145	S-80829ANNP-EDS-T2	S-80829ANY	S-80829ANUP-EDS-T2	—
3.0V±2.0%	0.150	S-80830ANNP-EDT-T2	S-80830ANY	S-80830ANUP-EDT-T2	S-80830ANMP-EDT-T2
3.1V±2.0%	0.155	S-80831ANNP-EDV-T2	S-80831ANY	S-80831ANUP-EDV-T2	—
3.2V±2.0%	0.160	S-80832ANNP-EDW-T2	S-80832ANY	S-80832ANUP-EDW-T2	S-80832ANMP-EDW-T2
3.3V±2.0%	0.165	S-80833ANNP-EDX-T2	S-80833ANY	S-80833ANUP-EDX-T2	S-80833ANMP-EDX-T2
3.4V±2.0%	0.170	S-80834ANNP-EDY-T2	S-80834ANY	S-80834ANUP-EDY-T2	S-80834ANMP-EDY-T2
3.5V±2.0%	0.175	S-80835ANNP-EDZ-T2	S-80835ANY	S-80835ANUP-EDZ-T2	S-80835ANMP-EDZ-T2
3.6V±2.0%	0.180	S-80836ANNP-ED0-T2	S-80836ANY	S-80836ANUP-ED0-T2	S-80836ANMP-ED0-T2
3.7V±2.0%	0.185	S-80837ANNP-ED1-T2	S-80837ANY	S-80837ANUP-ED1-T2	—
3.8V±2.0%	0.190	S-80838ANNP-ED2-T2	S-80838ANY	S-80838ANUP-ED2-T2	—
3.9V±2.0%	0.195	S-80839ANNP-ED3-T2	S-80839ANY	S-80839ANUP-ED3-T2	S-80839ANMP-ED3-T2
4.0V±2.0%	0.200	S-80840ANNP-ED4-T2	S-80840ANY	S-80840ANUP-ED4-T2	S-80840ANMP-ED4-T2
4.1V±2.0%	0.205	S-80841ANNP-ED5-T2	S-80841ANY	S-80841ANUP-ED5-T2	—
4.2V±2.0%	0.210	S-80842ANNP-ED6-T2	S-80842ANY	S-80842ANUP-ED6-T2	S-80842ANMP-ED6-T2
4.3V±2.0%	0.215	S-80843ANNP-ED7-T2	S-80843ANY	S-80843ANUP-ED7-T2	—
4.4V±2.0%	0.220	S-80844ANNP-ED8-T2	S-80844ANY	S-80844ANUP-ED8-T2	S-80844ANMP-ED8-T2
4.5V±2.0%	0.225	S-80845ANNP-ED9-T2	S-80845ANY	S-80845ANUP-ED9-T2	S-80845ANMP-ED9-T2
4.6V±2.0%	0.230	S-80846ANNP-EJA-T2	S-80846ANY	S-80846ANUP-EJA-T2	—
4.7V±2.0%	0.235	S-80847ANNP-EJB-T2	S-80847ANY	S-80847ANUP-EJB-T2	—
4.8V±2.0%	0.240	S-80848ANNP-EJC-T2	S-80848ANY	S-80848ANUP-EJC-T2	—
4.9V±2.0%	0.245	S-80849ANNP-EJD-T2	S-80849ANY	S-80849ANUP-EJD-T2	—
5.0V±2.0%	0.250	S-80850ANNP-EJE-T2	S-80850ANY	S-80850ANUP-EJE-T2	S-80850ANMP-EJE-T2
5.1V±2.0%	0.255	S-80851ANNP-EJF-T2	S-80851ANY	S-80851ANUP-EJF-T2	S-80851ANMP-EJF-T2
5.2V±2.0%	0.260	S-80852ANNP-EJG-T2	—	S-80852ANUP-EJG-T2	—
5.3V±2.0%	0.265	S-80853ANNP-EJH-T2	S-80853ANY	—	—
5.4V±2.0%	0.270	S-80854ANNP-EJJ-T2	—	—	—
5.5V±2.0%	0.275	S-80855ANNP-EJK-T2	—	—	—
5.6V±2.0%	0.280	S-80856ANNP-EJL-T2	—	—	—
5.7V±2.0%	0.285	S-80857ANNP-EJM-T2	—	—	—
5.8V±2.0%	0.290	S-80858ANNP-EJN-T2	—	—	—
5.9V±2.0%	0.295	S-80859ANNP-EJP-T2	—	—	—
6.0V±2.0%	0.300	S-80860ANNP-EJQ-T2	—	S-80860ANUP-EJQ-T2	—

# SUPER-SMALL PACKAGE HIGH-PRECISION VOLTAGE DETECTOR

## S-808 Series

Detection voltage range (V)	Hysteresis width $V_{HYS}$ typ.(V)	CMOS Output Drain(Low)			
		SC-82AB	TO-92	SOT-89-3	SOT-23-5
0.8V±2.0%	0.034	S-80808ALNP-E5Y-T2	—	—	—
0.9V±2.0%	0.044	S-80809ALNP-E5Z-T2	—	—	—
1.0V±2.0%	0.054	S-80810ALNP-E50-T2	—	—	—
1.1V±2.0%	0.064	S-80811ALNP-E51-T2	—	—	—
1.2V±2.0%	0.073	S-80812ALNP-E52-T2	—	—	—
1.3V±2.0%	0.083	S-80813ALNP-EAA-T2	—	—	—
1.4V±2.0%	0.093	S-80814ALNP-EAB-T2	—	—	—
1.5V±2.0%	0.075	S-80815ALNP-EAC-T2	S-80815ALY	S-80815ALUP-EAC-T2	S-80815ALMP-EAC-T2
1.6V±2.0%	0.080	S-80816ALNP-EAD-T2	S-80816ALY	S-80816ALUP-EAD-T2	—
1.7V±2.0%	0.085	S-80817ALNP-EAE-T2	S-80817ALY	S-80817ALUP-EAE-T2	—
1.8V±2.0%	0.090	S-80818ALNP-EAF-T2	S-80818ALY	S-80818ALUP-EAF-T2	S-80818ALMP-EAF-T2
1.9V±2.0%	0.095	S-80819ALNP-EAG-T2	S-80819ALY	S-80819ALUP-EAG-T2	S-80819ALMP-EAG-T2
2.0V±2.0%	0.100	S-80820ALNP-EAH-T2	S-80820ALY	S-80820ALUP-EAH-T2	S-80820ALMP-EAH-T2
2.1V±2.0%	0.105	S-80821ALNP-EAJ-T2	S-80821ALY	S-80821ALUP-EAJ-T2	S-80821ALMP-EAJ-T2
2.2V±2.0%	0.110	S-80822ALNP-EAK-T2	S-80822ALY	S-80822ALUP-EAK-T2	—
2.3V±2.0%	0.115	S-80823ALNP-EAL-T2	S-80823ALY	S-80823ALUP-EAL-T2	S-80823ALMP-EAL-T2
2.4V±2.0%	0.120	S-80824ALNP-EAM-T2	S-80824ALY	S-80824ALUP-EAM-T2	—
2.5V±2.0%	0.125	S-80825ALNP-EAN-T2	S-80825ALY	S-80825ALUP-EAN-T2	S-80825ALMP-EAN-T2
2.6V±2.0%	0.130	S-80826ALNP-EAP-T2	S-80826ALY	S-80826ALUP-EAP-T2	—
2.7V±2.0%	0.135	S-80827ALNP-EAQ-T2	S-80827ALY	S-80827ALUP-EAQ-T2	S-80827ALMP-EAQ-T2
2.8V±2.0%	0.140	S-80828ALNP-EAR-T2	S-80828ALY	S-80828ALUP-EAR-T2	S-80828ALMP-EAR-T2
2.9V±2.0%	0.145	S-80829ALNP-EAS-T2	S-80829ALY	S-80829ALUP-EAS-T2	—
3.0V±2.0%	0.150	S-80830ALNP-EAT-T2	S-80830ALY	S-80830ALUP-EAT-T2	S-80830ALMP-EAT-T2
3.1V±2.0%	0.155	S-80831ALNP-EAV-T2	S-80831ALY	S-80831ALUP-EAV-T2	—
3.2V±2.0%	0.160	S-80832ALNP-EAW-T2	S-80832ALY	S-80832ALUP-EAW-T2	S-80832ALMP-EAW-T2
3.3V±2.0%	0.165	S-80833ALNP-EAX-T2	S-80833ALY	S-80833ALUP-EAX-T2	S-80833ALMP-EAX-T2
3.4V±2.0%	0.170	S-80834ALNP-EAY-T2	S-80834ALY	S-80834ALUP-EAY-T2	—
3.5V±2.0%	0.175	S-80835ALNP-EAZ-T2	S-80835ALY	S-80835ALUP-EAZ-T2	S-80835ALMP-EAZ-T2
3.6V±2.0%	0.180	S-80836ALNP-EA0-T2	S-80836ALY	S-80836ALUP-EA0-T2	—
3.7V±2.0%	0.185	S-80837ALNP-EA1-T2	S-80837ALY	S-80837ALUP-EA1-T2	—
3.8V±2.0%	0.190	S-80838ALNP-EA2-T2	S-80838ALY	S-80838ALUP-EA2-T2	—
3.9V±2.0%	0.195	S-80839ALNP-EA3-T2	S-80839ALY	S-80839ALUP-EA3-T2	—
4.0V±2.0%	0.200	S-80840ALNP-EA4-T2	S-80840ALY	S-80840ALUP-EA4-T2	S-80840ALMP-EA4-T2
4.1V±2.0%	0.205	S-80841ALNP-EA5-T2	S-80841ALY	S-80841ALUP-EA5-T2	—
4.2V±2.0%	0.210	S-80842ALNP-EA6-T2	S-80842ALY	S-80842ALUP-EA6-T2	S-80842ALMP-EA6-T2
4.3V±2.0%	0.215	S-80843ALNP-EA7-T2	S-80843ALY	S-80843ALUP-EA7-T2	—
4.4V±2.0%	0.220	S-80844ALNP-EA8-T2	S-80844ALY	S-80844ALUP-EA8-T2	—
4.5V±2.0%	0.225	S-80845ALNP-EA9-T2	S-80845ALY	S-80845ALUP-EA9-T2	S-80845ALMP-EA9-T2
4.6V±2.0%	0.230	S-80846ALNP-EEA-T2	S-80846ALY	S-80846ALUP-EEA-T2	—
4.7V±2.0%	0.235	S-80847ALNP-EEB-T2	S-80847ALY	S-80847ALUP-EEB-T2	—
4.8V±2.0%	0.240	S-80848ALNP-EEC-T2	S-80848ALY	S-80848ALUP-EEC-T2	—
4.9V±2.0%	0.245	S-80849ALNP-EED-T2	S-80849ALY	S-80849ALUP-EED-T2	S-80849ALMP-EED-T2
5.0V±2.0%	0.250	S-80850ALNP-EEE-T2	S-80850ALY	S-80850ALUP-EEE-T2	S-80850ALMP-EEE-T2
5.1V±2.0%	0.255	S-80851ALNP-EEF-T2	S-80851ALY	S-80851ALUP-EEF-T2	S-80851ALMP-EEF-T2
5.2V±2.0%	0.260	S-80852ALNP-EEG-T2	—	S-80852ALUP-EEG-T2	S-80852ALMP-EEG-T2
5.3V±2.0%	0.265	S-80853ALNP-EEH-T2	—	—	—
5.4V±2.0%	0.270	S-80854ALNP-EEJ-T2	—	—	—
5.5V±2.0%	0.275	S-80855ALNP-EEK-T2	—	S-80855ALUP-EEK-T2	—
5.6V±2.0%	0.280	S-80856ALNP-EEL-T2	—	—	—
5.7V±2.0%	0.285	S-80857ALNP-EEM-T2	—	—	—
5.8V±2.0%	0.290	S-80858ALNP-EEN-T2	—	—	—
5.9V±2.0%	0.295	S-80859ALNP-EEP-T2	—	—	—
6.0V±2.0%	0.300	S-80860ALNP-EEQ-T2	—	—	—

Remark: Some products described here in are under development. Please contact us for Samples.

■ **Output Configurations**

1. S-808 Series model numbering system

	Nch open-drain (“L” reset type)	CMOS output (“L” reset type)
S-808 Series	“N” is the last letter of the model number. e.g. S-80808AN	“L” is the last letter of the model number. e.g. S-80808AL

2. Output configurations and their implementation

Implementation	Nch(“L”)	CMOS(“L”)
With different power supplies	Yes	No
With active low reset CPUs	Yes	Yes
With active high reset CPUs	No	No
With voltage divider variable resistors	Yes	No

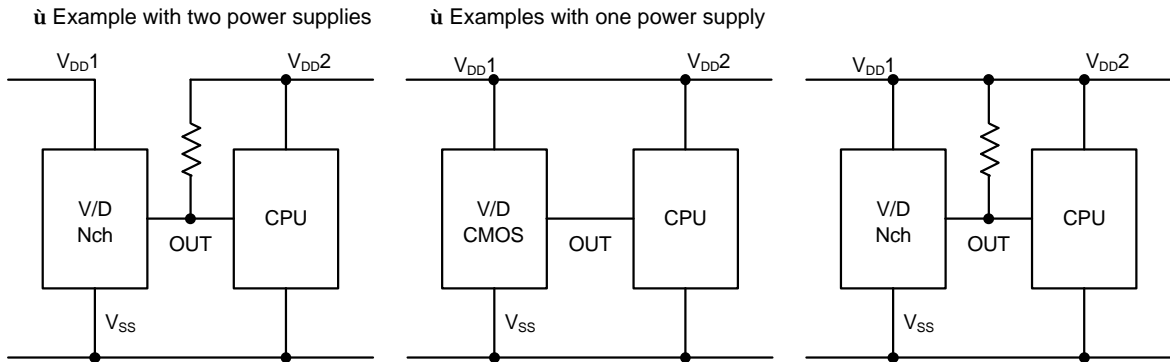

Figure 3

# SUPER-SMALL PACKAGE HIGH-PRECISION VOLTAGE DETECTOR

## S-808 Series

### ■ Absolute Maximum Ratings

1. Products with detection voltage of 1.4 V or less

(Unless otherwise specified: Ta=25°C)

Parameter	Symbol	Ratings	Unit	
Power supply voltage	$V_{DD} - V_{SS}$	7	V	
Output voltage	Nch open-drain CMOS	$V_{OUT}$	$V_{SS}-0.3$ to 7	V
			$V_{SS}-0.3$ to $V_{DD}+0.3$	V
Output current	$I_{OUT}$	50	mA	
Power dissipation	Pd	150	mW	
Operating temperature	Topr	-20 to +70	°C	
Storage temperature	Tstg	-40 to +125	°C	

2. Products with detection voltage of 1.5 V or more

(Unless otherwise specified: Ta=25°C)

Parameter	Symbol	Ratings	Unit	
Power supply voltage	$V_{DD} - V_{SS}$	12	V	
Output voltage	Nch open-drain CMOS	$V_{OUT}$	$V_{SS}-0.3$ to 12	V
			$V_{SS}-0.3$ to $V_{DD}+0.3$	V
Output current	$I_{OUT}$	50	mA	
Power dissipation	Pd	TO-92	400	mW
		SOT-89-3	500	
		SC-82AB,SOT-23-5	150	
Operating temperature	Topr	-40 to +85	°C	
Storage temperature	Tstg	-40 to +125	°C	

Remark: This IC has a built-in protection circuit for static electricity. However, prevent contact with a large static electricity or electrostatic voltage which exceeds the performance of the protection circuit

**SUPER-SMALL PACKAGE HIGH-PRECISION VOLTAGE DETECTOR**  
**S-808 Series**

■ **Electrical Characteristics**

1. Detection voltage (0.8 V to 1.4 V)

(Unless otherwise specified: Ta=25°C)

Parameter	Symbol	Conditions	Min.	Typ.	Max.	Unit	Test circuit	
Detection voltage	-V <sub>DET</sub>	S-80808AX	0.784	0.800	0.816	V	1	
		S-80809AX	0.882	0.900	0.918			
		S-80810AX	0.980	1.000	1.020			
		S-80811AX	1.078	1.100	1.122			
		S-80812AX	1.176	1.200	1.224			
		S-80813AX	1.274	1.300	1.326			
		S-80814AX	1.372	1.400	1.428			
Release voltage	+V <sub>DET</sub>	S-80808AX	0.802	0.834	0.867	V	1	
		S-80809AX	0.910	0.944	0.979			
		S-80810AX	1.017	1.054	1.091			
		S-80811AX	1.125	1.164	1.203			
		S-80812AX	1.232	1.273	1.315			
		S-80813AX	1.340	1.383	1.427			
		S-80814AX	1.448	1.493	1.538			
Hysteresis width	V <sub>HYS</sub>	S-80808AX	0.018	0.034	0.051	V	1	
		S-80809AX	0.028	0.044	0.061			
		S-80810AX	0.037	0.054	0.071			
		S-80811AX	0.047	0.064	0.081			
		S-80812AX	0.056	0.073	0.091			
		S-80813AX	0.066	0.083	0.101			
		S-80814AX	0.076	0.093	0.110			
Current consumption	I <sub>SS</sub>	V <sub>DD</sub> =1.5V	S-80808AX	—	1.3	3.7	μA	2
			S-80809AX					
		V <sub>DD</sub> =2.0V	S-80810AX					
			S-80811AX					
			S-80812AX					
			S-80813AX					
			S-80814AX					
Operating voltage	V <sub>DD</sub>		0.7	—	5.0	V	1	
Output current	I <sub>OUT</sub>	Nch	V <sub>DS</sub> =0.5V	0.04	0.2	—	mA	3
			V <sub>DD</sub> =0.7V					
		Pch(CMOS output)	V <sub>DS</sub> =2.1V	2.9	5.8	—		4
			V <sub>DD</sub> =4.5V					
Leakage current of output transistor	I <sub>LEAK</sub>	Nch(Nch open drain)	V <sub>DS</sub> =5.0V	—	—	60	nA	3
			V <sub>DD</sub> =5.0V					
Temperature characteristic of -V <sub>DET</sub>	Δ-V <sub>DET</sub> ΔTa	Ta=-20°C to +70°C	S-80808AX	—	±0.18	—	mV/°C	1
			S-80809AX	—	±0.20	—		
			S-80810AX	—	±0.22	—		
			S-80811AX	—	±0.24	—		
			S-80812AX	—	±0.27	—		
			S-80813AX	—	±0.29	—		
			S-80814AX	—	±0.31	—		

# SUPER-SMALL PACKAGE HIGH-PRECISION VOLTAGE DETECTOR

## S-808 Series

### 2. Detection voltage (1.5 V to 2.6 V)

(Unless otherwise specified: Ta=25°C)

Parameter	Symbol	Conditions	Min.	Typ.	Max.	Unit	Test circuit	
Detection voltage	-V <sub>DET</sub>	S-80815AX	1.470	1.500	1.530	V	1	
		S-80816AX	1.568	1.600	1.632			
		S-80817AX	1.666	1.700	1.734			
		S-80818AX	1.764	1.800	1.836			
		S-80819AX	1.862	1.900	1.938			
		S-80820AX	1.960	2.000	2.040			
		S-80821AX	2.058	2.100	2.142			
		S-80822AX	2.156	2.200	2.244			
		S-80823AX	2.254	2.300	2.346			
		S-80824AX	2.352	2.400	2.448			
		S-80825AX	2.450	2.500	2.550			
S-80826AX	2.548	2.600	2.652					
Hysteresis width	V <sub>HYS</sub>		-V <sub>DET</sub> ×0.03	-V <sub>DET</sub> ×0.05	-V <sub>DET</sub> ×0.08	V	1	
Current consumption	I <sub>SS</sub>	V <sub>DD</sub> =3.5V	—	0.8	2.4	μA	2	
Operating voltage	V <sub>DD</sub>		0.95	—	10.0	V	1	
Output current	I <sub>OUT</sub>	Nch V <sub>DS</sub> =0.5V V <sub>DD</sub> =1.2V	0.23	0.50	—	mA	3	
		Pch(CMOS output) V <sub>DS</sub> =0.5V V <sub>DD</sub> =4.8V	0.36	0.62	—		4	
Leakage current of output transistor	I <sub>LEAK</sub>	Nch(Nch open drain) V <sub>DS</sub> =10.0 V V <sub>DD</sub> =10.0 V	—	—	0.1	μA	3	
Response time	t <sub>PLH</sub>		—	—	60	μs	1	
Temperature characteristic of -V <sub>DET</sub>	Δ-V <sub>DET</sub> ΔTa	Ta=-40°C to +85°C	S-80815AX	—	±0.18	±0.54	mV/°C	1
			S-80816AX	—	±0.19	±0.57		
			S-80817AX	—	±0.20	±0.60		
			S-80818AX	—	±0.21	±0.63		
			S-80819AX	—	±0.22	±0.66		
			S-80820AX	—	±0.24	±0.72		
			S-80821AX	—	±0.25	±0.75		
			S-80822AX	—	±0.26	±0.78		
			S-80823AX	—	±0.27	±0.81		
			S-80824AX	—	±0.28	±0.84		
			S-80825AX	—	±0.29	±0.87		
S-80826AX	—	±0.31	±0.93					



**SUPER-SMALL PACKAGE HIGH-PRECISION VOLTAGE DETECTOR**  
**S-808 Series**

3. Detection voltage (2.7 V to 3.9 V)

(Unless otherwise specified: Ta=25°C)

Parameter	Symbol	Conditions	Min.	Typ.	Max.	Unit	Test circuit	
Detection voltage	-V <sub>DET</sub>	S-80827AX	2.646	2.700	2.754	V	1	
		S-80828AX	2.744	2.800	2.856			
		S-80829AX	2.842	2.900	2.958			
		S-80830AX	2.940	3.000	3.060			
		S-80831AX	3.038	3.100	3.162			
		S-80832AX	3.136	3.200	3.264			
		S-80833AX	3.234	3.300	3.366			
		S-80834AX	3.332	3.400	3.468			
		S-80835AX	3.430	3.500	3.570			
		S-80836AX	3.528	3.600	3.672			
		S-80837AX	3.626	3.700	3.774			
		S-80838AX	3.724	3.800	3.876			
S-80839AX	3.822	3.900	3.978					
Hysteresis width	V <sub>HYS</sub>		-V <sub>DET</sub> ×0.03	-V <sub>DET</sub> ×0.05	-V <sub>DET</sub> ×0.08	V	1	
Current consumption	I <sub>SS</sub>	V <sub>DD</sub> =4.5V	—	0.9	2.7	μA	2	
Operating voltage	V <sub>DD</sub>		0.95	—	10.0	V	1	
Output current	I <sub>OUT</sub>	Nch	V <sub>DD</sub> =1.2V	0.23	0.50	—	mA	3
		V <sub>DS</sub> =0.5V	V <sub>DD</sub> =2.4V	1.60	3.70	—		
		Pch(CMOS output)	V <sub>DD</sub> =4.8V	0.36	0.62	—		
Leakage current of output transistor	I <sub>LEAK</sub>	Nch(Nch open drain)	V <sub>DS</sub> =10.0 V V <sub>DD</sub> =10.0 V	—	—	0.1	μA	3
Response time	t <sub>PLH</sub>		—	—	60	μs	1	
Temperature characteristic of -V <sub>DET</sub>	$\frac{\Delta-V_{DET}}{\Delta T_a}$	Ta=-40°C to +85°C	S-80827AX	—	±0.32	±0.96	mV/°C	1
			S-80828AX	—	±0.33	±0.99		
			S-80829AX	—	±0.34	±1.02		
			S-80830AX	—	±0.35	±1.05		
			S-80831AX	—	±0.36	±1.08		
			S-80832AX	—	±0.38	±1.14		
			S-80833AX	—	±0.39	±1.17		
			S-80834AX	—	±0.40	±1.20		
			S-80835AX	—	±0.41	±1.23		
			S-80836AX	—	±0.42	±1.26		
			S-80837AX	—	±0.44	±1.32		
			S-80838AX	—	±0.45	±1.35		
S-80839AX	—	±0.46	±1.38					

# SUPER-SMALL PACKAGE HIGH-PRECISION VOLTAGE DETECTOR

## S-808 Series

### 4. Detection voltage (4.0 V to 5.6 V)

(Unless otherwise specified: Ta=25°C)

Parameter	Symbol	Conditions	Min.	Typ.	Max.	Unit	Test circuit	
Detection voltage	-V <sub>DET</sub>	S-80840AX	3.920	4.000	4.080	V	1	
		S-80841AX	4.018	4.100	4.182			
		S-80842AX	4.116	4.200	4.284			
		S-80843AX	4.214	4.300	4.386			
		S-80844AX	4.312	4.400	4.488			
		S-80845AX	4.410	4.500	4.590			
		S-80846AX	4.508	4.600	4.692			
		S-80847AX	4.606	4.700	4.794			
		S-80848AX	4.704	4.800	4.896			
		S-80849AX	4.802	4.900	4.998			
		S-80850AX	4.900	5.000	5.100			
		S-80851AX	4.998	5.100	5.202			
		S-80852AX	5.096	5.200	5.304			
		S-80853AX	5.194	5.300	5.406			
		S-80854AX	5.292	5.400	5.508			
S-80855AX	5.390	5.500	5.610					
S-80856AX	5.488	5.600	5.712					
Hysteresis width	V <sub>HYS</sub>		-V <sub>DET</sub> ×0.03	-V <sub>DET</sub> ×0.05	-V <sub>DET</sub> ×0.08	V	1	
Current consumption	I <sub>SS</sub>	V <sub>DD</sub> =6.0V	—	1.0	3.0	μA	2	
Operating voltage	V <sub>DD</sub>		0.95	—	10.0	V	1	
Output current	I <sub>OUT</sub>	Nch	V <sub>DD</sub> =1.2V	0.23	0.50	—	mA	3
		V <sub>DS</sub> =0.5V	V <sub>DD</sub> =2.4V	1.60	3.70	—		
		Pch(CMOS output)	V <sub>DD</sub> =6.0V	0.46	0.75	—		4
Leakage current of output transistor	I <sub>LEAK</sub>	Nch(Nch open drain)	V <sub>DS</sub> =10.0 V V <sub>DD</sub> =10.0 V	—	—	0.1	μA	3
Response time	tPLH		—	—	60	μs	1	
Temperature characteristic of -V <sub>DET</sub>	$\frac{\Delta -V_{DET}}{\Delta T_a}$	Ta=-40°C to +85°C	S-80840AX	—	±0.47	±1.41	mV/°C	1
			S-80841AX	—	±0.48	±1.44		
			S-80842AX	—	±0.49	±1.47		
			S-80843AX	—	±0.51	±1.53		
			S-80844AX	—	±0.52	±1.56		
			S-80845AX	—	±0.53	±1.59		
			S-80846AX	—	±0.54	±1.62		
			S-80847AX	—	±0.55	±1.65		
			S-80848AX	—	±0.56	±1.68		
			S-80849AX	—	±0.58	±1.74		
			S-80850AX	—	±0.59	±1.77		
			S-80851AX	—	±0.60	±1.80		
			S-80852AX	—	±0.61	±1.83		
			S-80853AX	—	±0.62	±1.86		
			S-80854AX	—	±0.64	±1.92		
S-80855AX	—	±0.65	±1.95					
S-80856AX	—	±0.66	±1.98					

# SUPER-SMALL PACKAGE HIGH-PRECISION VOLTAGE DETECTOR S-808 Series

## 5. Detection voltage (5.7 V to 6.0 V)

(Unless otherwise specified:  $T_a=25^\circ\text{C}$ )

Parameter	Symbol	Conditions	Min.	Typ.	Max.	Unit	Test circuit	
Detection voltage	$-V_{\text{DET}}$	S-80857AX	5.586	5.700	5.814	V	1	
		S-80858AX	5.684	5.800	5.916			
		S-80859AX	5.782	5.900	6.018			
		S-80860AX	5.880	6.000	6.120			
Hysteresis width	$V_{\text{HYS}}$		$-V_{\text{DET}} \times 0.03$	$-V_{\text{DET}} \times 0.05$	$-V_{\text{DET}} \times 0.08$	V	1	
Current consumption	$I_{\text{SS}}$	$V_{\text{DD}}=7.5\text{V}$	—	1.0	3.0	$\mu\text{A}$	2	
Operating voltage	$V_{\text{DD}}$		0.95	—	10.0	V	1	
Output current	$I_{\text{OUT}}$	Nch $V_{\text{DS}}=0.5\text{V}$	$V_{\text{DD}}=1.2\text{V}$ 0.23	0.50	—	mA	3	
			$V_{\text{DD}}=2.4\text{V}$ 1.60	3.70	—			
		Pch(CMOS output) $V_{\text{DS}}=0.5\text{V}$	$V_{\text{DD}}=8.4\text{V}$ 0.59	0.96	—			4
Leakage current of output transistor	$I_{\text{LEAK}}$	Nch(Nch open drain) $V_{\text{DS}}=10.0\text{V}$ $V_{\text{DD}}=10.0\text{V}$	—	—	0.1	$\mu\text{A}$	3	
Response time	$t_{\text{PLH}}$		—	—	60	$\mu\text{s}$	1	
Temperature characteristic of $-V_{\text{DET}}$	$\frac{\Delta -V_{\text{DET}}}{\Delta T_a}$	$T_a=-40^\circ\text{C}$ to $+85^\circ\text{C}$	S-80857AX	—	$\pm 0.67$	$\pm 2.01$	mV/ $^\circ\text{C}$	1
			S-80858AX	—	$\pm 0.68$	$\pm 2.04$		
			S-80859AX	—	$\pm 0.69$	$\pm 2.07$		
			S-80860AX	—	$\pm 0.71$	$\pm 2.13$		

### ■ Test Circuits

(1)

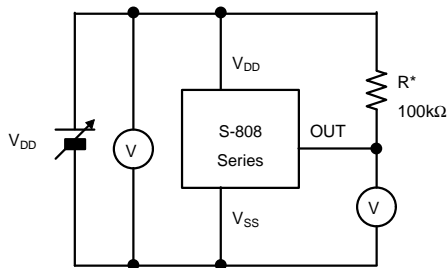

\* R is unnecessary for CMOS output products.

(2)

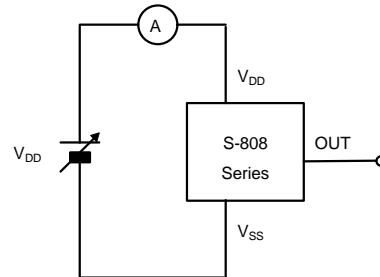

(3)

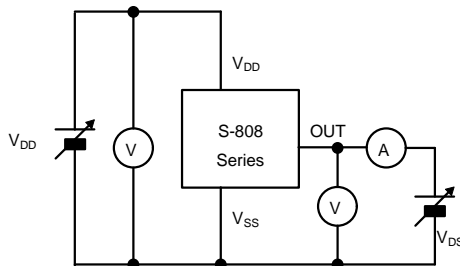

(4)

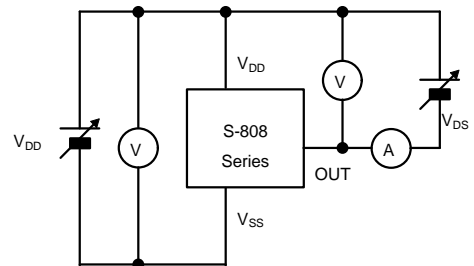

Figure 4

# SUPER-SMALL PACKAGE HIGH-PRECISION VOLTAGE DETECTOR

## S-808 Series

### ■ Technical Terms

#### 1. Detection voltage ( $-V_{DET}$ )

The detection voltage  $-V_{DET}$  is the voltage at which the output switches to low. This detection voltage varies slightly among products of the same type. The variation of voltages between the specified minimum [ $(-V_{DET})_{min.}$ ] and maximum [ $(-V_{DET})_{max.}$ ] values is called the detection voltage range (See Figure 5).

**Example :** For the S-80808AN, detection voltage lies in the range of  $0.784 \leq (-V_{DET}) \leq 0.816$ .

This means that  $-V_{DET}$  is 0.784 in a product while  $-V_{DET}$  is 0.816 in another of the same S-80808AN.

#### 2. Release voltage ( $+V_{DET}$ )

The release voltage  $+V_{DET}$  is the voltage at which the output returns (is “released”) to high. This release voltage varies slightly among products of the same type. The variation of voltages between the specified minimum [ $(+V_{DET})_{min.}$ ] and maximum [ $(+V_{DET})_{max.}$ ] values is called the release voltage range (See Figure 6).

**Example :** For the S-80808AN, the release voltage lies in the range of  $0.802 \leq (+V_{DET}) \leq 0.867$ . This means that  $+V_{DET}$  is 0.802 in a product while  $+V_{DET}$  is 0.867 in another of the same S-80808AN.

**Remark:** Although the detection voltage and release voltage overlap in the range of 0.802 V to 0.816 V,  $+V_{DET}$  will always be larger than  $-V_{DET}$ .

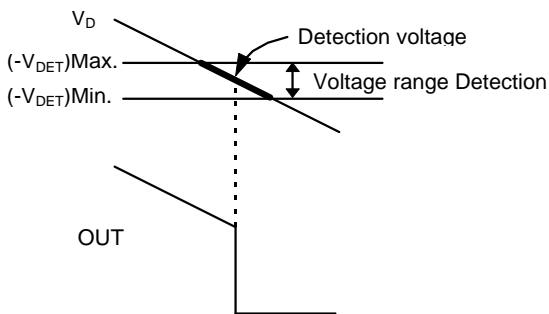

Figure 5

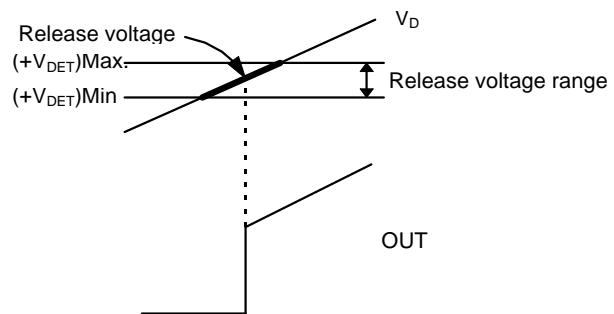

Figure 6

#### 3. Hysteresis width ( $V_{HYS}$ )

The hysteresis width is the voltage difference between the detection voltage and the release voltage ( $B-A=V_{HYS}$  in Figure 10). By giving a device hysteresis, trouble such as noise at the input is avoided.

#### 4. Through-type current

Through-type current refers to the current which flows instantaneously at the time of detection and release of a voltage detector. Through-type current is large in CMOS output devices, and also flows to some extent in Nch open-drain output devices.

5. Oscillation

In applications where a resistor is connected to the voltage detector input (Figure 7), in the CMOS active low products for example, the through-type current generated when the output goes from low to high (release) causes a voltage drop equal to [through-type current]×[input resistance] across the resistor. When the resultant input voltage drops below the detection voltage  $-V_{DET}$ , the output voltage returns to its low level. In this state, the through-type current and its resultant voltage drop have disappeared, and the output goes back from low to high. A through-type current is again generated, a voltage drop appears, and the process repeats. This unstable condition is referred to as oscillation.

⚠ Misimplementation with input voltage divider

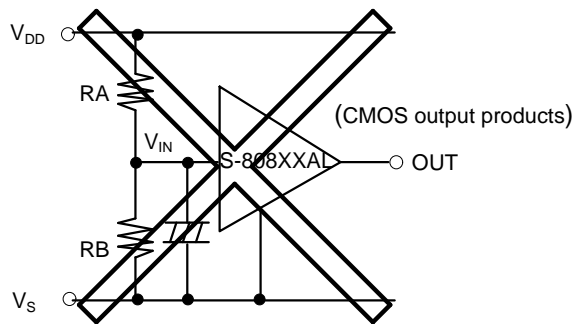
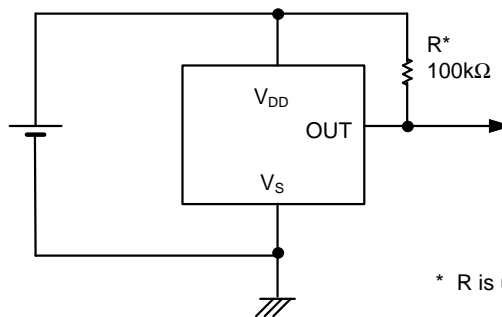

Figure 7

■ Standard Circuit



\* R is unnecessary for\* CMOS output

Figure 8

# SUPER-SMALL PACKAGE HIGH-PRECISION VOLTAGE DETECTOR

## S-808 Series

### ■ Operation

#### 1. Basic operation : CMOS active low output

- (1) When power supply voltage  $V_{DD}$  is greater than the release voltage  $+V_{DET}$ , the Nch transistor is OFF and the Pch transistor ON, causing  $V_{DD}$  (high) to appear at the output. With the Nch transistor N1 of Figure 9 OFF, the comparator input voltage is  $(RB+RC)/(RA+RB+RC) \times V_{DD}$ .
- (2) When power supply voltage  $V_{DD}$  goes below  $+V_{DET}$ , the output maintains the power supply voltage level, as long as  $V_{DD}$  remains above the detection voltage  $-V_{DET}$ . When  $V_{DD}$  does fall below  $-V_{DET}$  (A in Figure 10), the Nch transistor goes ON, the Pch transistor goes OFF, and  $V_{SS}$  appears at the output. With the Nch transistor N 1 of Figure 9 ON, the comparator input voltage is  $RB/(RA+RB) \times V_{DD}$ .
- (3) When  $V_{DD}$  falls below the minimum operating voltage, the output becomes undefined. However, output will revert to  $V_{DD}$  if a pull-up has been employed.
- (4)  $V_{SS}$  will again be output when  $V_{DD}$  rises above the minimum operating voltage.  $V_{SS}$  will continue to be output even when  $V_{DD}$  surpasses  $-V_{DET}$ , as long as it does not exceed the release voltage  $+V_{DET}$ .
- (5) When  $V_{DD}$  rises above  $+V_{DET}$  (B in Figure 10), the Nch transistor goes OFF, the Pch transistor goes ON, and  $V_{DD}$  appears at the output.

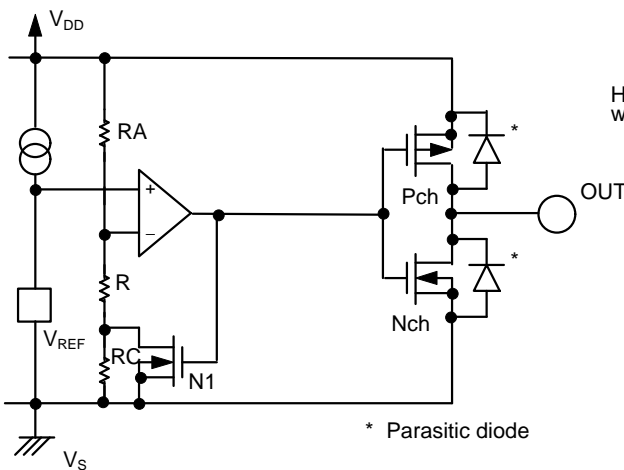

Figure 9

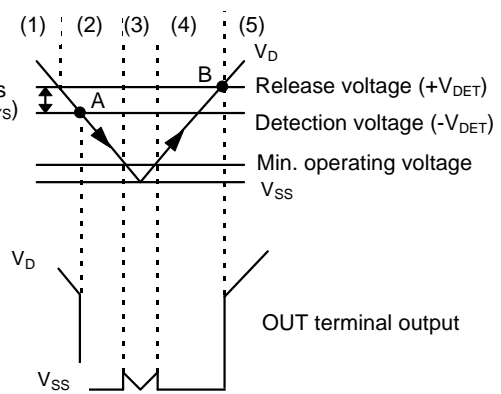

Figure 10

2. Other characteristics

(1) Temperature characteristic of detection voltage

The temperature characteristics of the detection voltage are expressed by the oblique line parts in Figure 11.

S-80815AXNP:

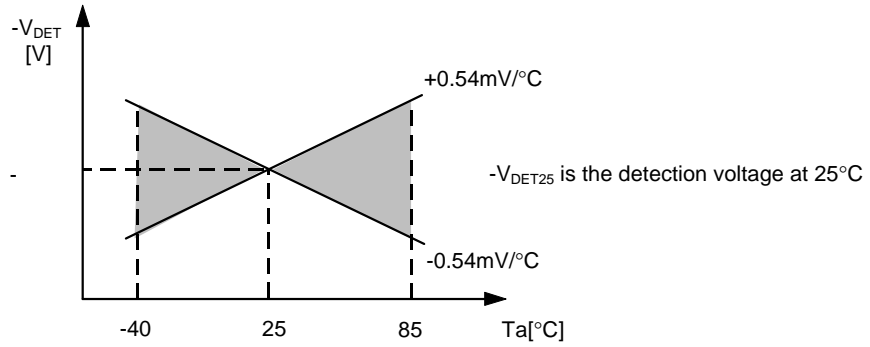

**Figure 11**

(2) Temperature characteristics of release voltage

The temperature factor  $\left(\frac{\Delta+V_{DET}}{\Delta Ta}\right)$  of the release voltage is calculated by the temperature factor of the detection voltage as follows:

$$\frac{\Delta+V_{DET}}{\Delta Ta} = \frac{+V_{DET}}{-V_{DET}} \times \frac{\Delta-V_{DET}}{\Delta Ta}$$

The temperature factor of the release voltage has a same sign characteristics as the temperature factor of the detection voltage.

(3) Temperature characteristics of hysteresis voltage

The temperature characteristics of hysteresis voltage  $\left(\frac{\Delta+V_{DET}}{\Delta Ta} - \frac{\Delta-V_{DET}}{\Delta Ta}\right)$  is calculated as

$$\frac{\Delta+V_{DET}}{\Delta Ta} - \frac{\Delta-V_{DET}}{\Delta Ta} = \frac{V_{HY}}{-V_{DET}} \times \frac{\Delta-V_{DET}}{\Delta Ta}$$

Remark: An example of temperature characteristics of (1) to (3) is shown on pages 16 and 17.

# SUPER-SMALL PACKAGE HIGH-PRECISION VOLTAGE DETECTOR

## S-808 Series

### ■ Characteristics (typical characteristics)

(1) Detection voltage ( $V_{DET}$ ) - Temperature ( $T_a$ )

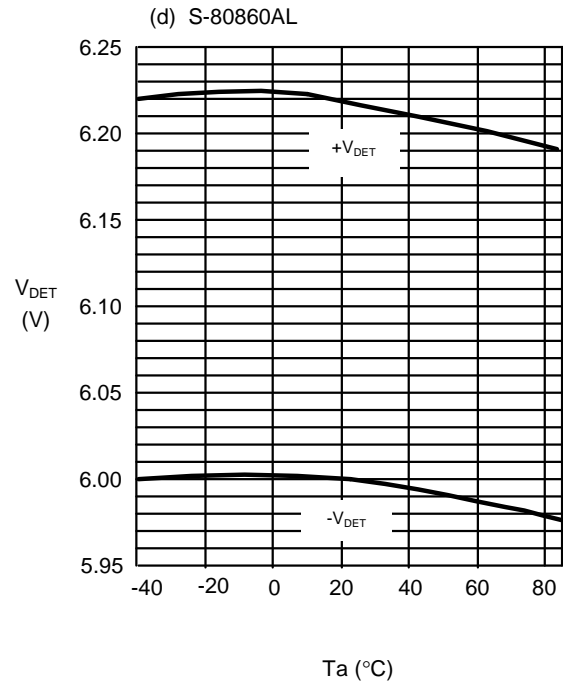
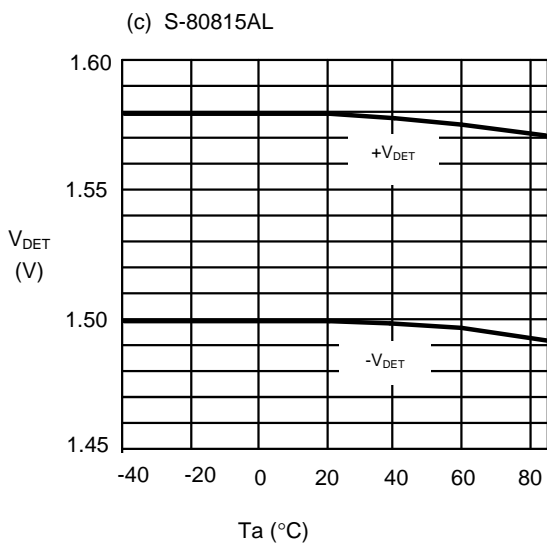
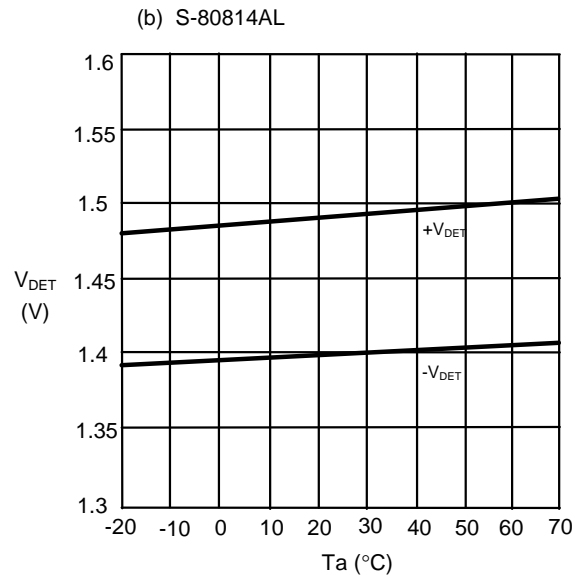
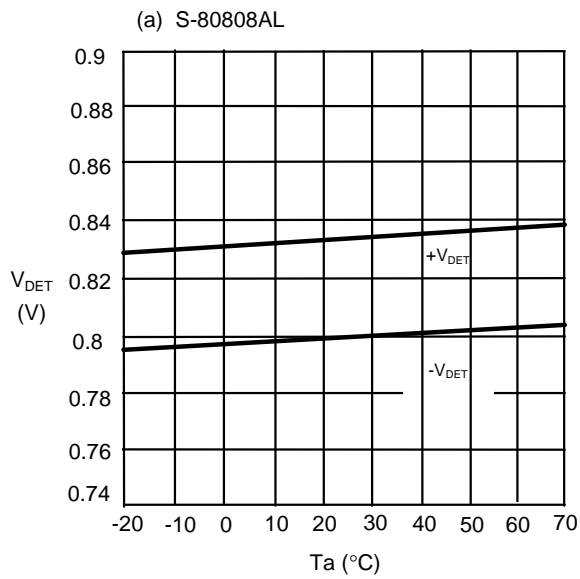



# SUPER-SMALL PACKAGE HIGH-PRECISION VOLTAGE DETECTOR

## S-808 Series

(2) Hysteresis voltage width ( $V_{HYS}$ ) - Temperature ( $T_a$ )

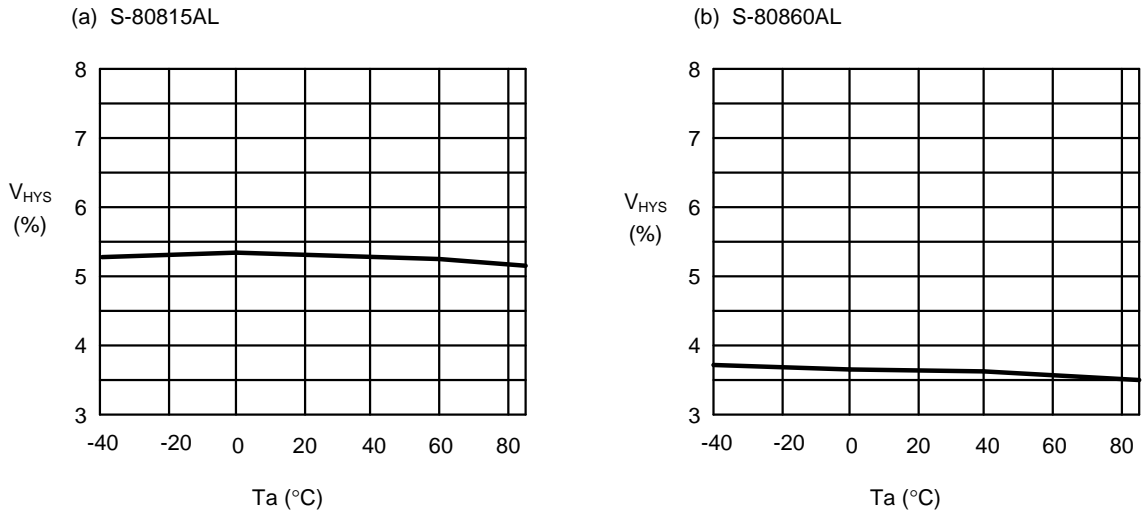

(3) Current consumption ( $I_{SS}$ ) - Input voltage ( $V_{DD}$ )

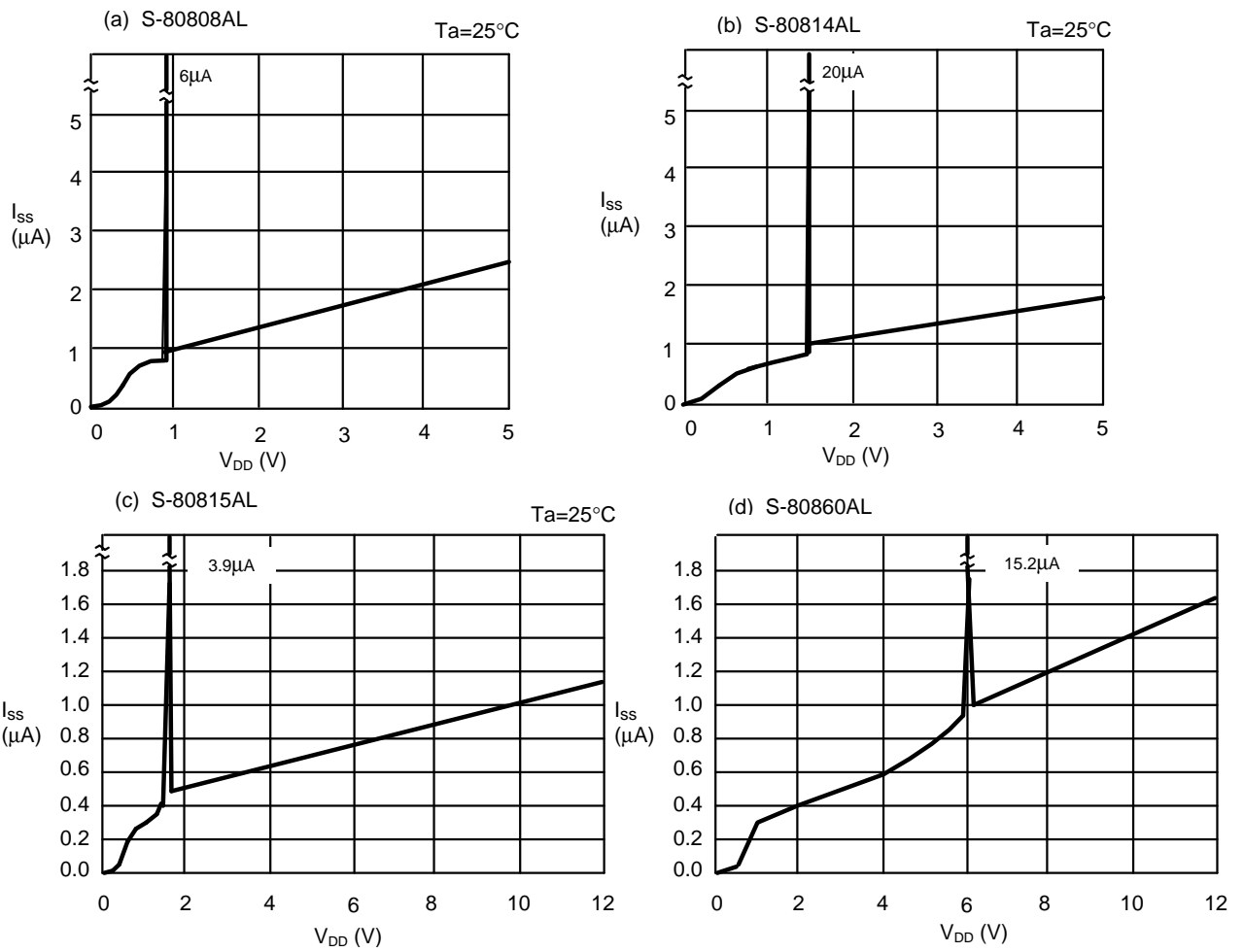

**SUPER-SMALL PACKAGE HIGH-PRECISION VOLTAGE DETECTOR**  
**S-808 Series**

---

(4) Current consumption ( $I_{SS}$ ) - Temperature ( $T_a$ )

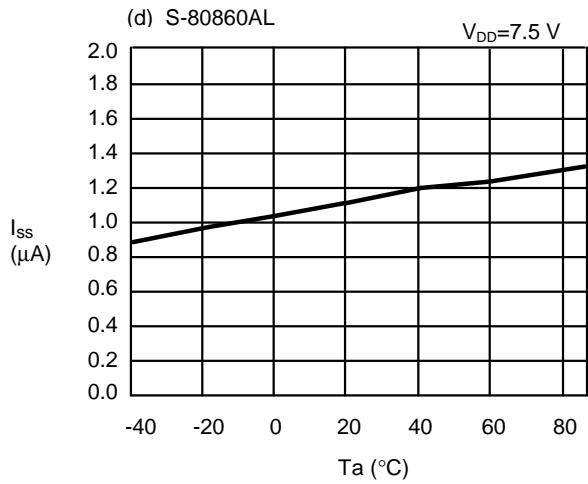
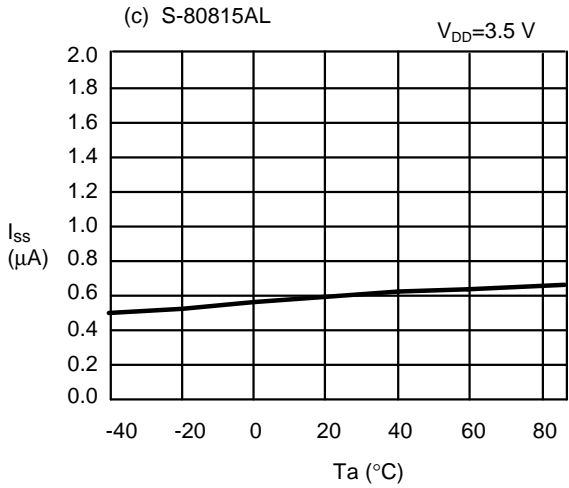
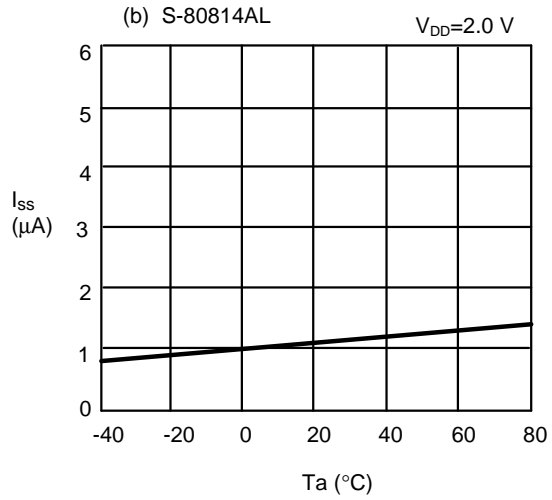
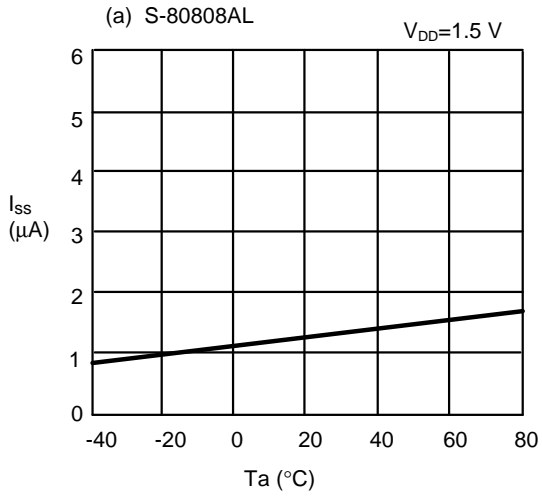

**SUPER-SMALL PACKAGE HIGH-PRECISION VOLTAGE DETECTOR**  
**S-808 Series**

(5) Nch transistor output current ( $I_{OUT}$ ) -  $V_{DS}$

(a) S-80814AL/AN

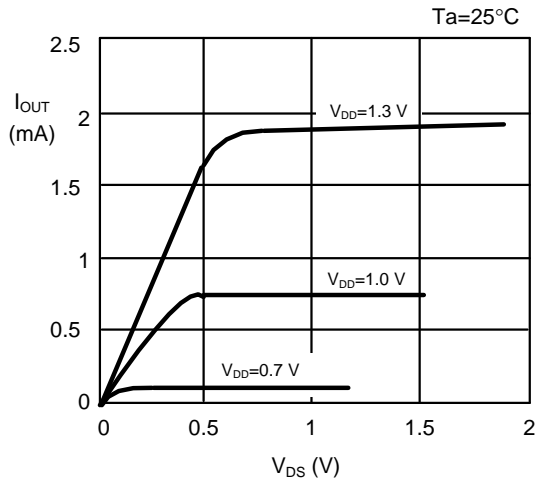

(b) S-80860AL/AN

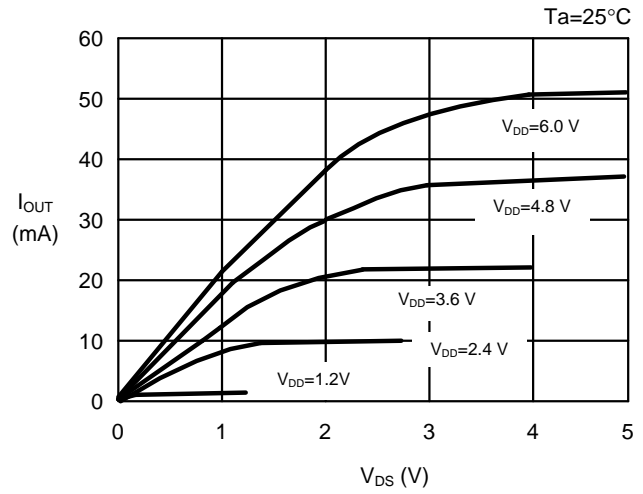

(6) Pch transistor output current ( $I_{OUT}$ ) -  $V_{DS}$

(a) S-80808AL

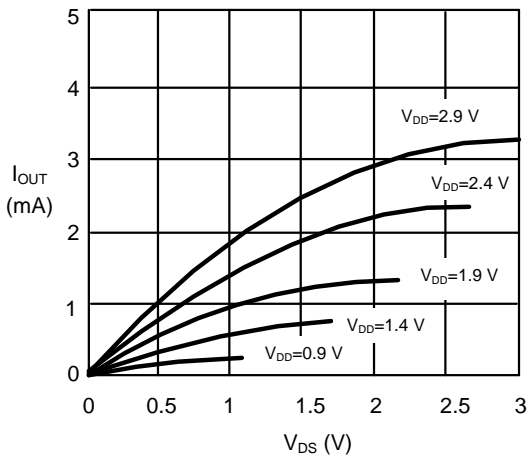

(b) S-80815AL

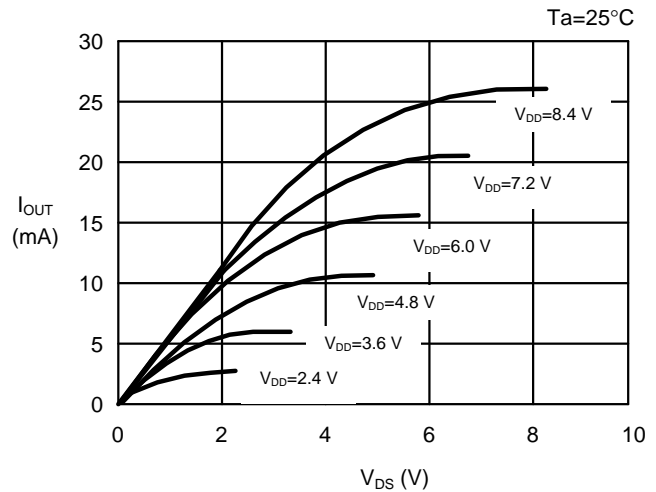

(7) Nch transistor output current ( $I_{OUT}$ ) - Input voltage ( $V_{DD}$ )

(a) S-80814AL/AN

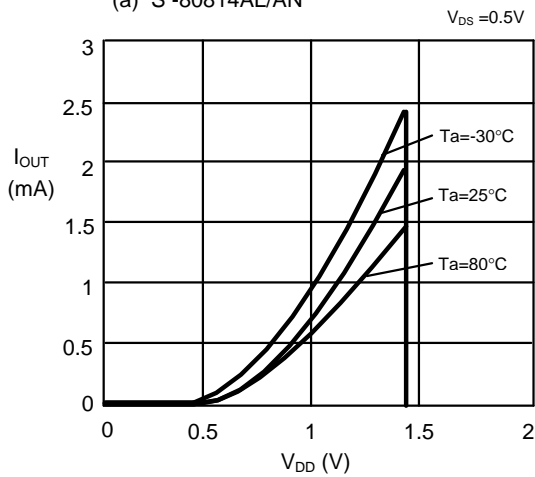

(b) S-80860AL/AN

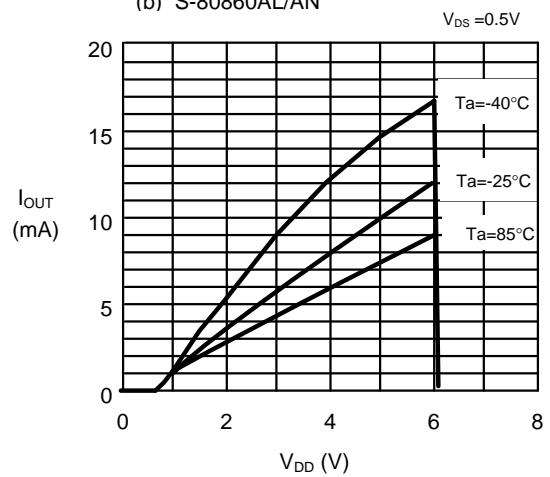

# SUPER-SMALL PACKAGE HIGH-PRECISION VOLTAGE DETECTOR

## S-808 Series

(8) Pch transistor output current ( $I_{OUT}$ ) - Input voltage ( $V_{DD}$ )

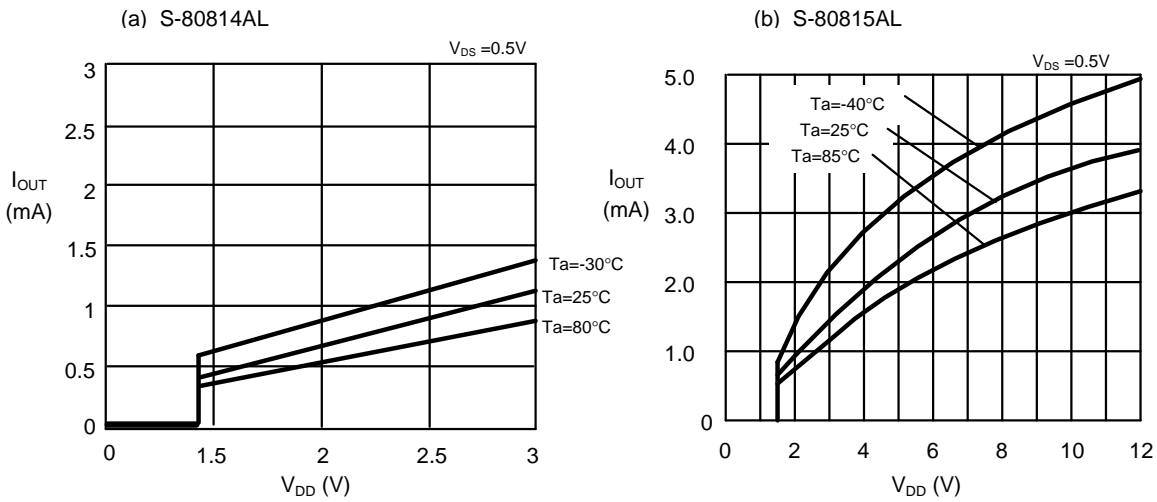

(9) Minimum operating voltage

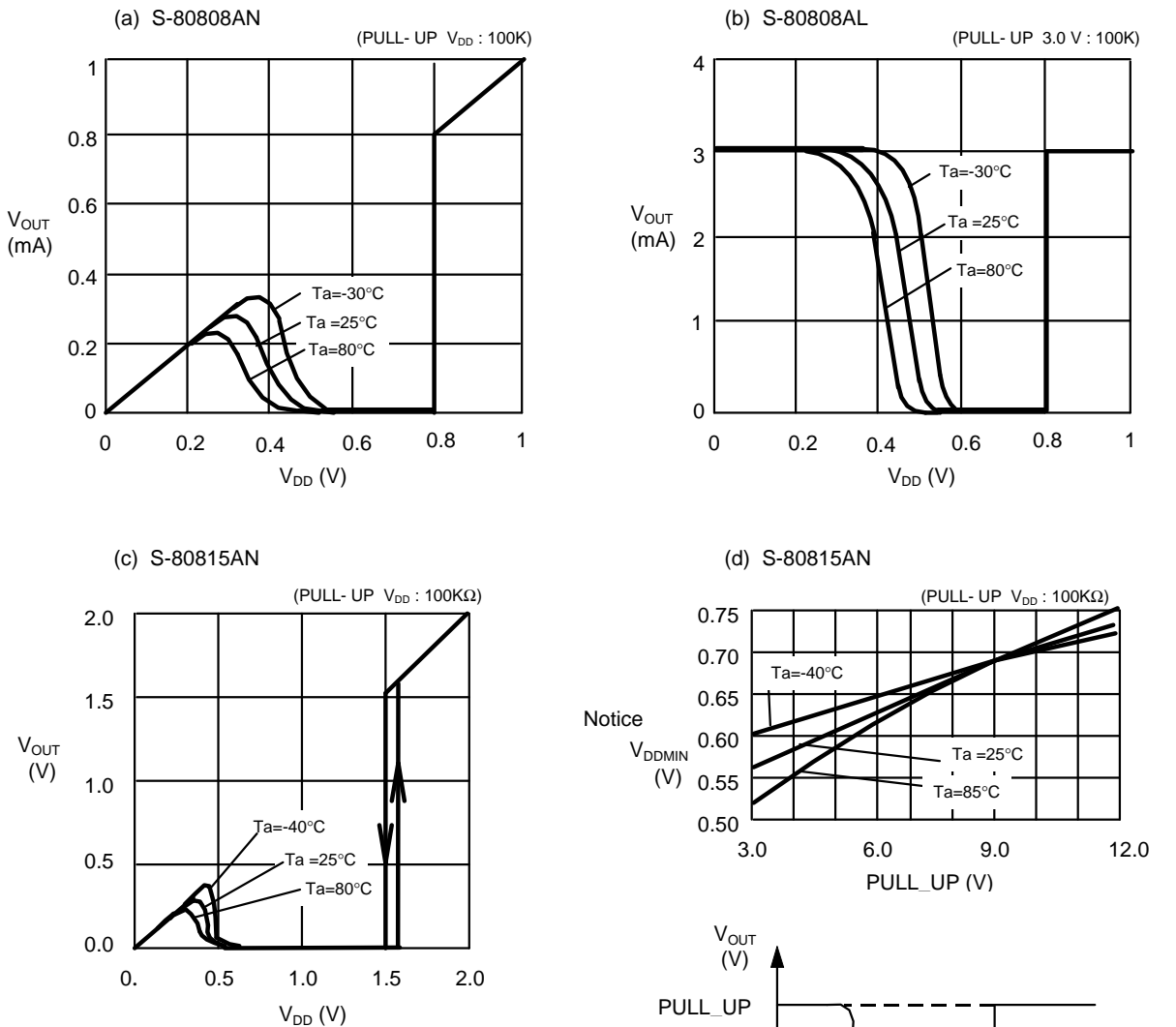

Remark:  
 $V_{DDMIN}$  is defined with  $V_{DD}$  when  $V_{OUT}$  goes below 10% of the PULL UP voltage as shown in Figure 12 when raising  $V_{DD}$  from 0 V.

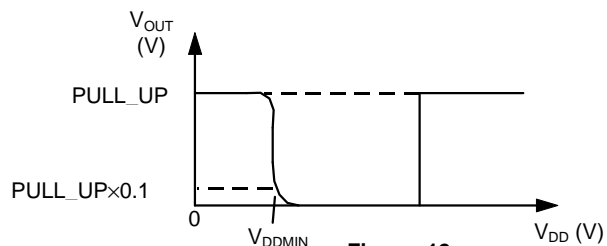

**SUPER-SMALL PACKAGE HIGH-PRECISION VOLTAGE DETECTOR**  
**S-808 Series**

(10) Dynamic response

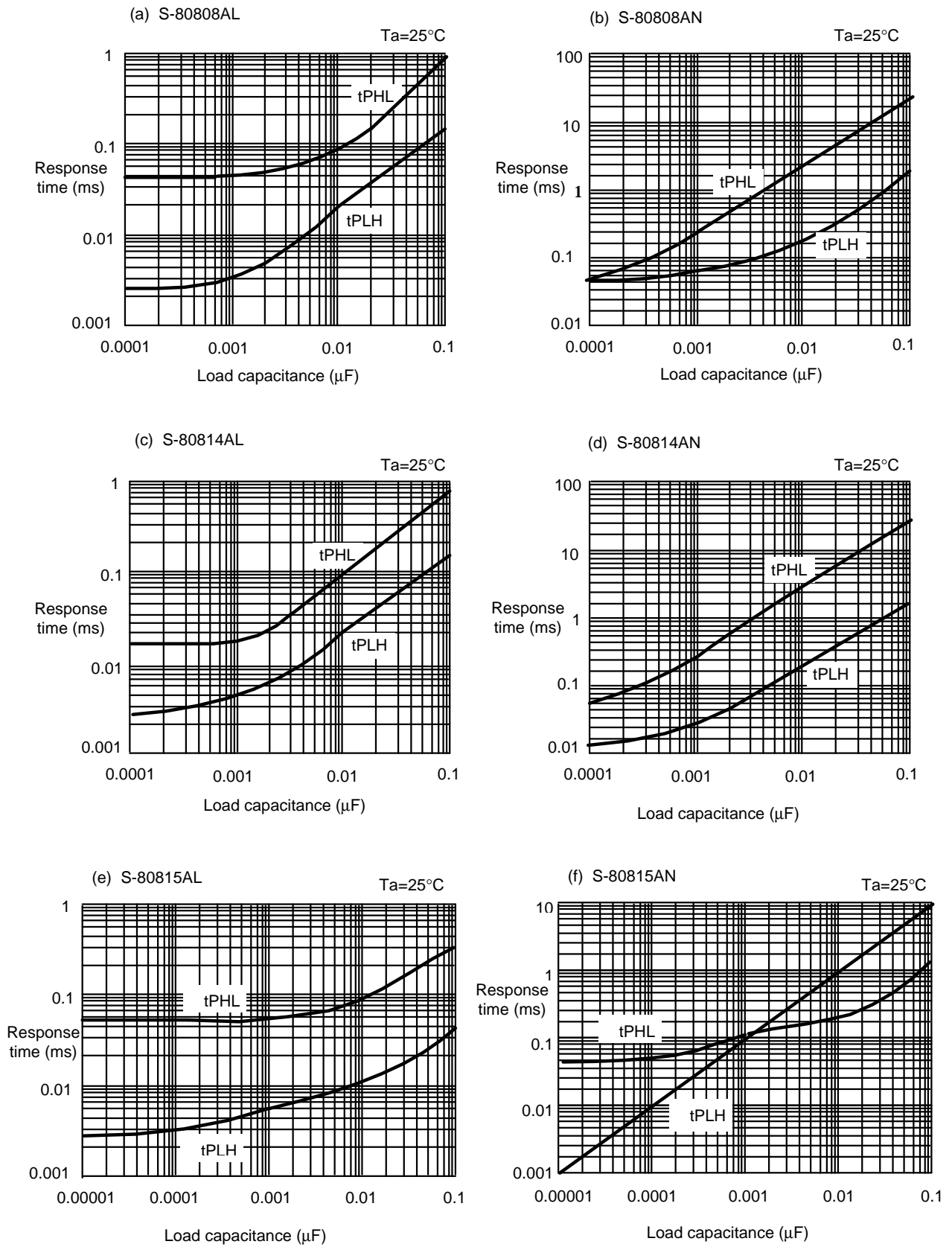

**SUPER-SMALL PACKAGE HIGH-PRECISION VOLTAGE DETECTOR**  
**S-808 Series**

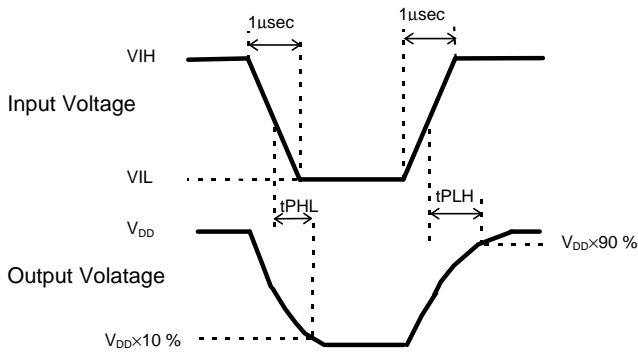
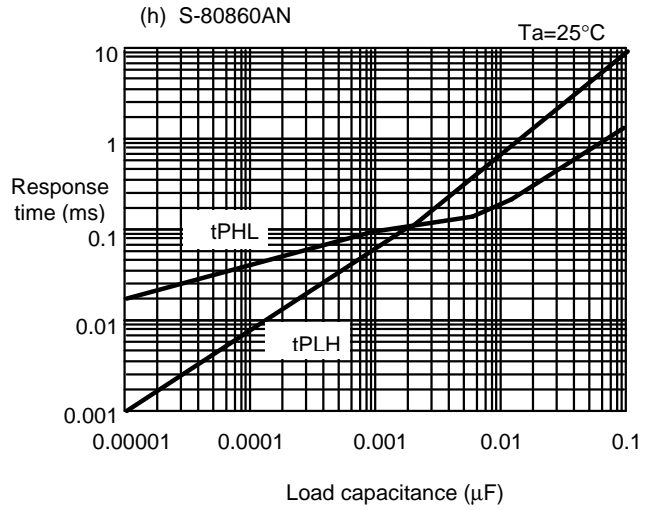
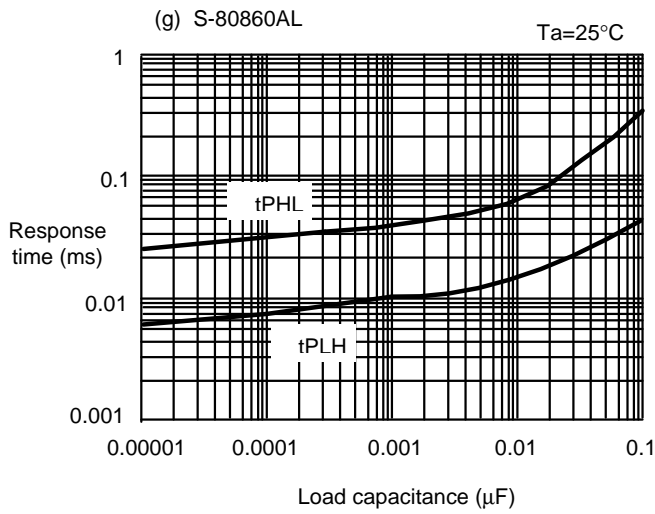

(a) - (d) :  $V_{IH}=5.0\text{V}$ ,  $V_{IL}=0.7\text{V}$   
 (e) - (h) :  $V_{IH}=10\text{V}$ ,  $V_{IL}=0.95\text{V}$

**Figure 13**

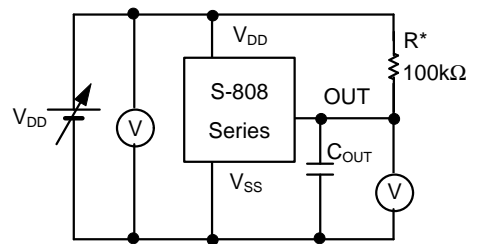

\* 'R' is not needed for CMOS output products.

**Figure 14**

■ **Application Circuit Examples**

1. Microcomputer reset circuits

If the power supply voltage to a microcomputer falls below the specified level, an unspecified operation may be performed or the contents of the memory register may be lost. When power supply voltage returns to normal, the microcomputer needs to be initialized before normal operations can be done.

Reset circuits protect microcomputers in the event of current being momentarily switched off or lowered. With the S-808 Series which has a low operating voltage, a high-precision detection voltage and hysteresis characteristic, the reset circuits shown in Figures 15 to 16 can be easily constructed.

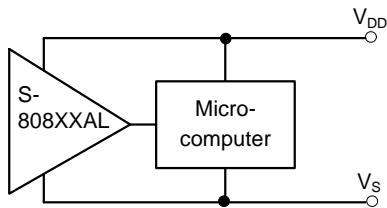

**Figure 15**

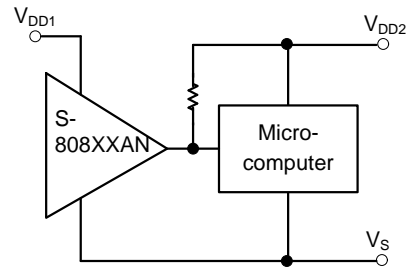

(Nch open-drain output products only)

**Figure 16**

2. Addition of power-on reset circuit

A power-on reset circuit can be constructed using Nch open-drain product of S-808 Series.

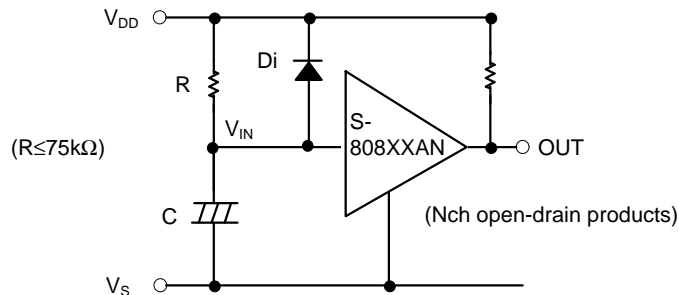

Note 1: R should be 75 kΩ or less for purpose of protection against oscillation.

Note 2: Di instantaneously discharges the electric charge stored by C at the falling of the power. Di is not necessary if delay in falling time is normal.

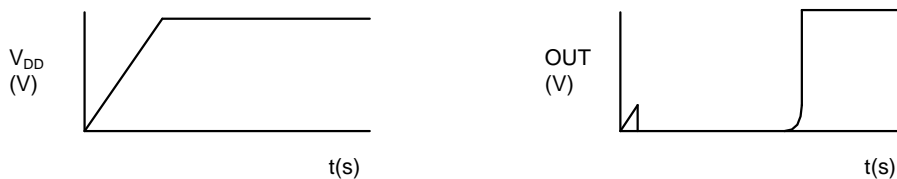

**Figure 17**

Note 3: When the power steeply rises, output may go high for a instant due to the IC inconstant region characteristics (output voltage is unstable in the region under minimum operating voltage) as shown in Figure. 18.

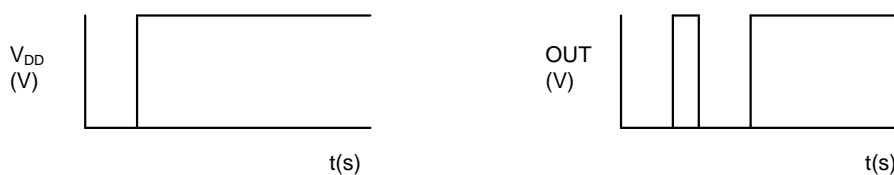
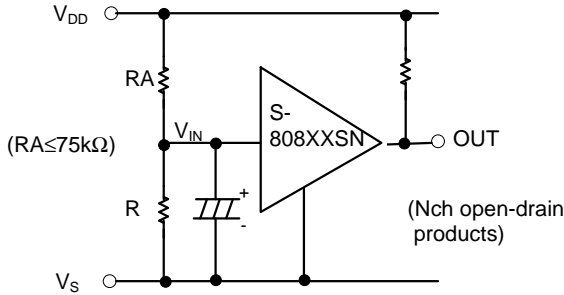

**Figure 18**

**SUPER-SMALL PACKAGE HIGH-PRECISION VOLTAGE DETECTOR**  
**S-808 Series**

3. Change of detection voltage

In Nch open-drain output products of the S-808 Series, detection voltage can be changed using resistance dividers or diodes as shown in Figures 19 and 20. In Figure 19, hysteresis width is also changed.



$$\text{Detection voltage} = \frac{RA+RB}{RB} \dot{u} -V_{DET}$$

$$\text{Hysteresis width} = \frac{RA+RB}{RB} \dot{u} V_{HYS}$$

Note1: If RA and RB are large, the hysteresis width may be larger than the value given by the formula above due to through-type current (which flows slightly in Nch open-drain circuit).

Note2: RA should be 75kΩ or less for purpose of protection against oscillation.

**Figure 19**

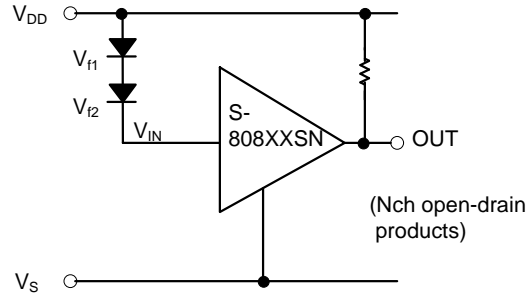

$$\text{Detection voltage} = V_{f1}+V_{f2}+ (-V_{DET})$$

**Figure 20**

■ **Remarks**

- In CMOS output products of the S-808 Series, through-type current flows when the device is detecting or releasing. If a high impedance is connected to the input, oscillation may be caused due to the fall of the voltage by the through-type current when lowering the voltage during releasing.
- When designing for mass production using an application circuit described herein, take the product deviation and temperature characteristic into consideration.
- Seiko Instruments Inc. shall not bear any responsibility for the patents on the circuits described herein.



# TO-92

YF003-A 990531

## Dimensions

### (1) Loose

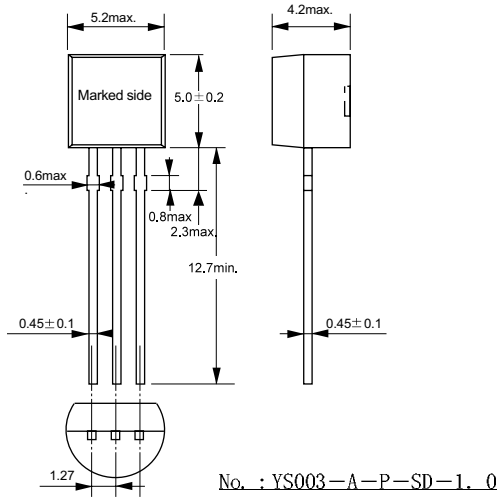

### (2) Taped (reel/zigzag) Unit:mm

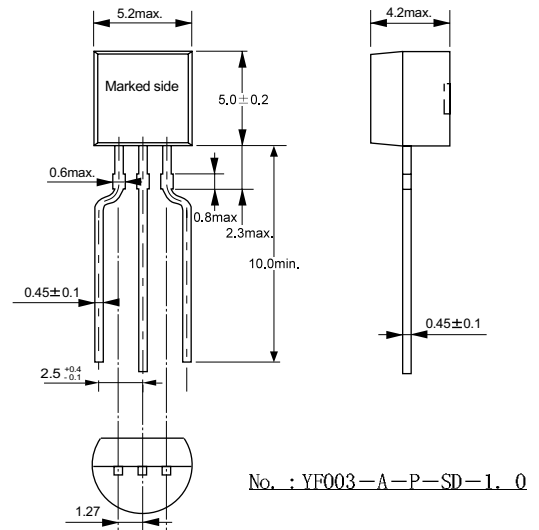

## Taping Specifications

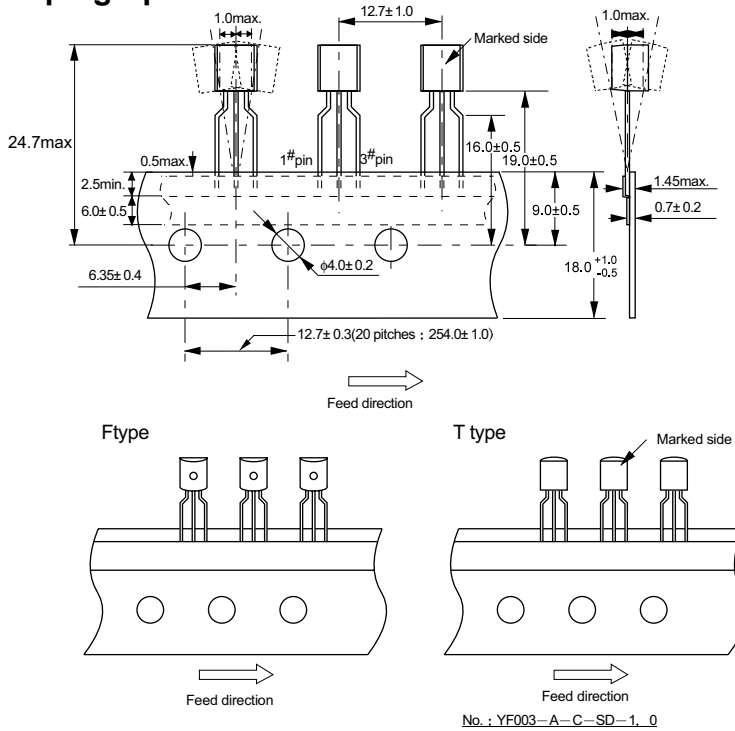

## Switch-back(wrap) Specifications

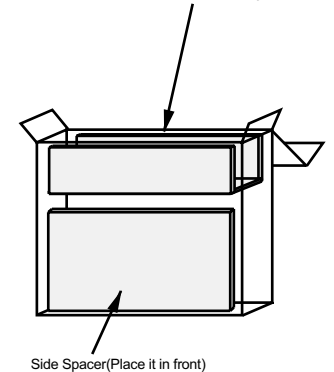
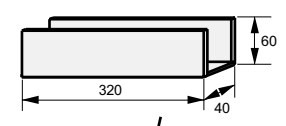
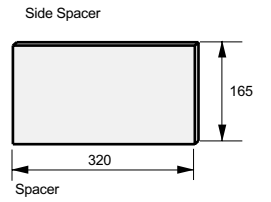

## Reel Specifications

1 reel holds 2000 ICs.

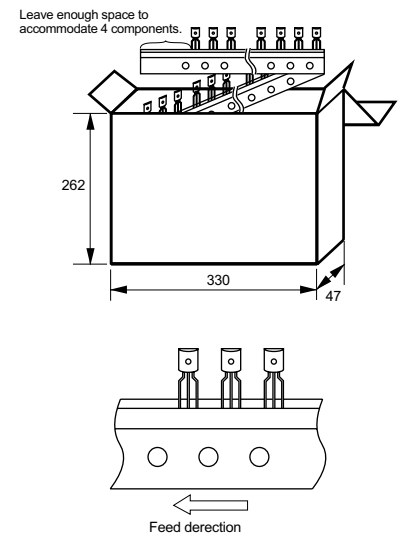
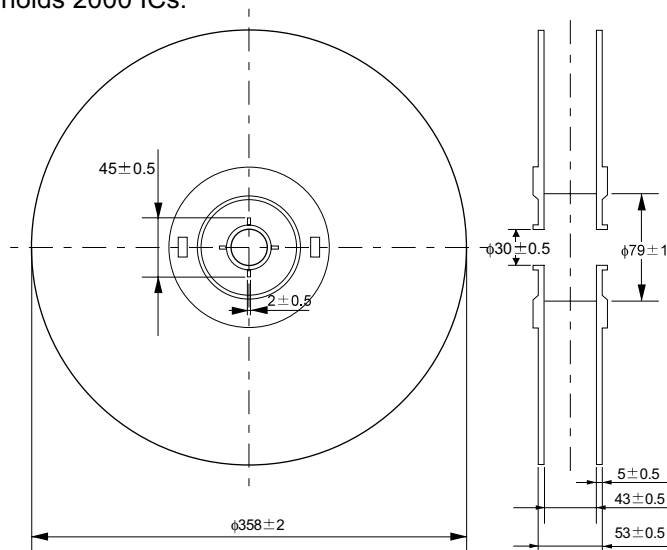

Unit:mm

●Dimensions

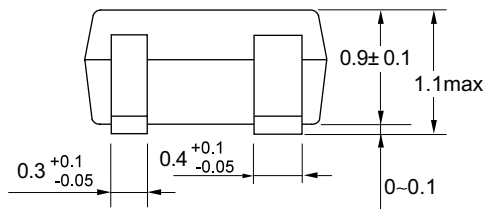
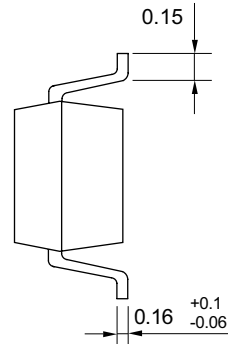
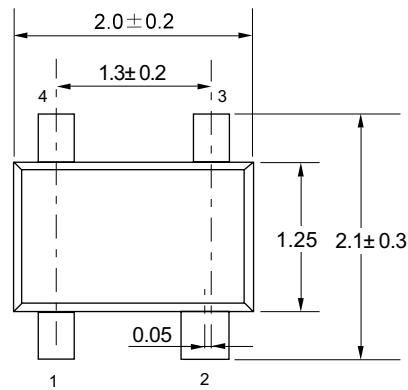

No. : NP004-A-P-SD-1.0

●Taping Specifications

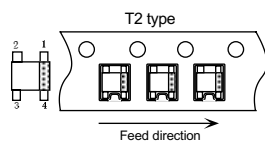
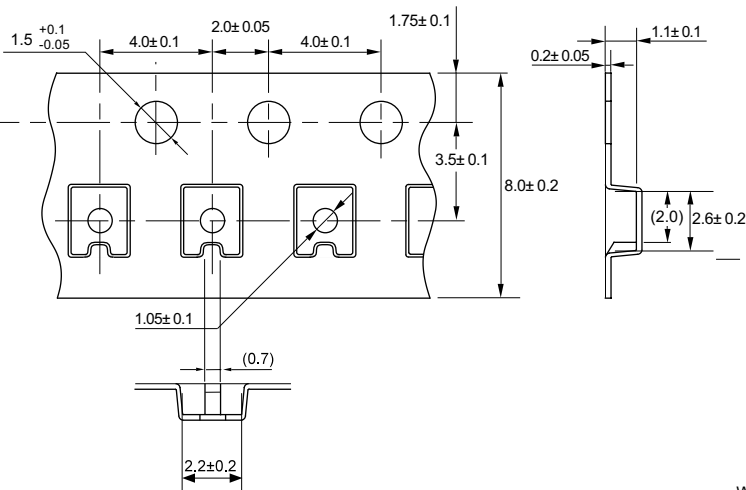

No. : NP004-A-C-SD-1.0

●Reel Specifications

1 reel holds 3000 ICs.

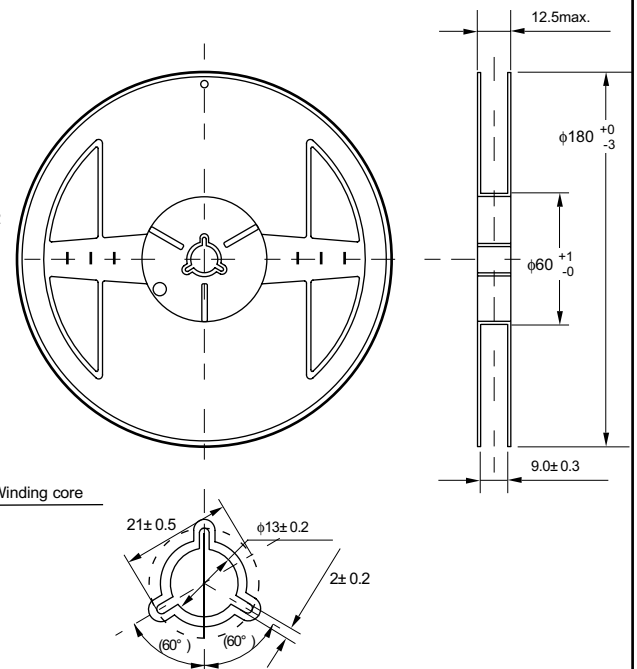

No. : NP004-A-R-SD-1.0

● Dimensions 外形図

Unit : mm

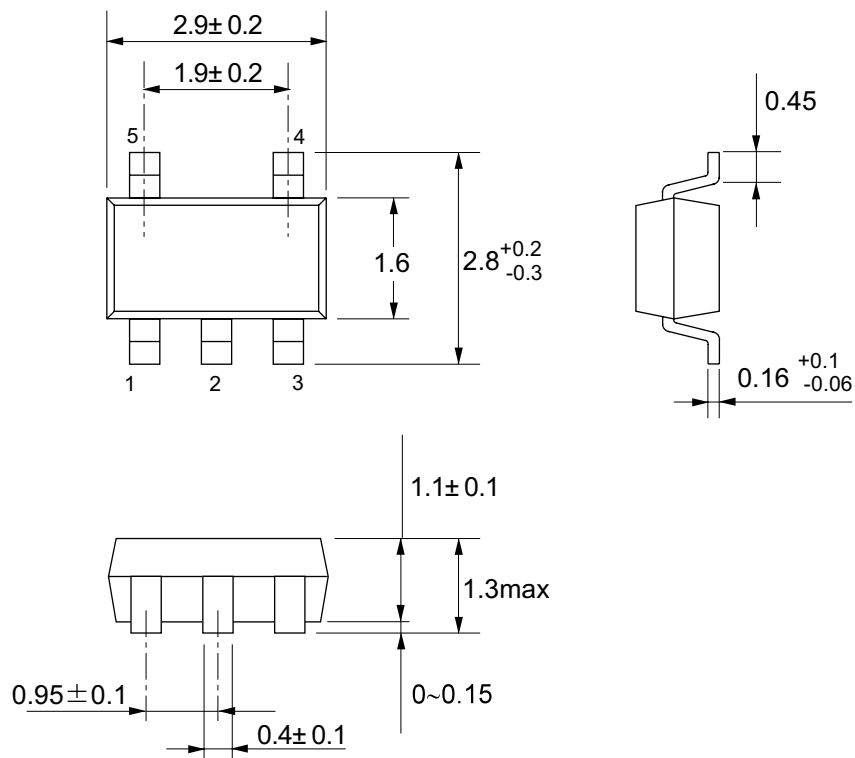

No. : MP005-A-P-SD-1.1

● Taping Specifications テーピング図

● Reel Specifications リール図

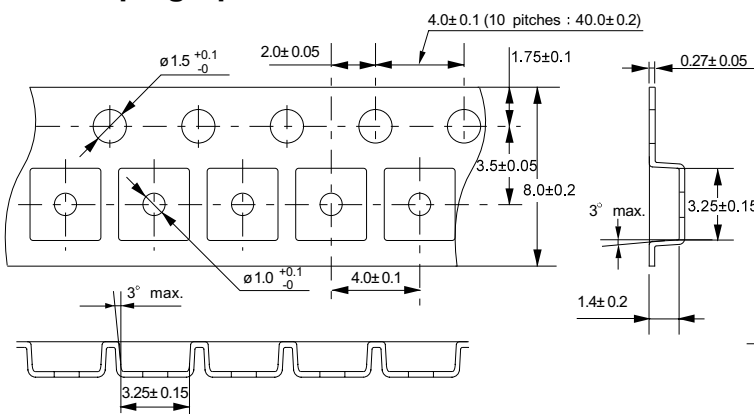

3000 pcs./reel

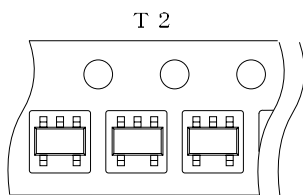
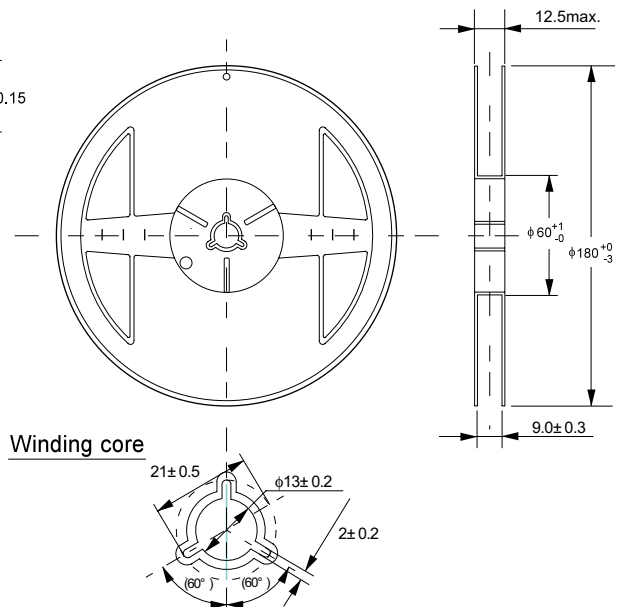

Feed direction  
引き出し方向

No. : MP005-A-C-SD-1.0

No. : MP005-A-R-SD-1.0

● Dimensions

Unit:mm

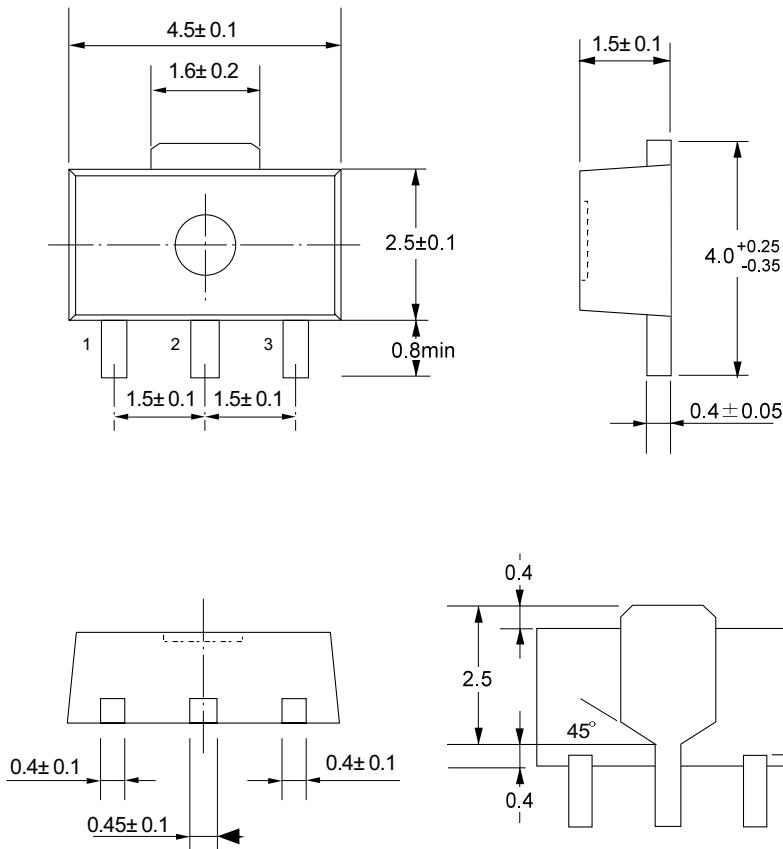

No. : UP003-A-P-SD-1.0

● Taping Specifications

● Reel Specifications

1 reel holds 1000 ICs.

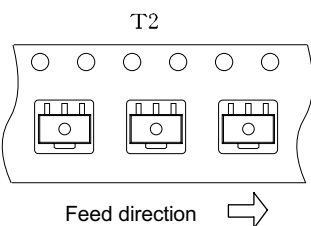
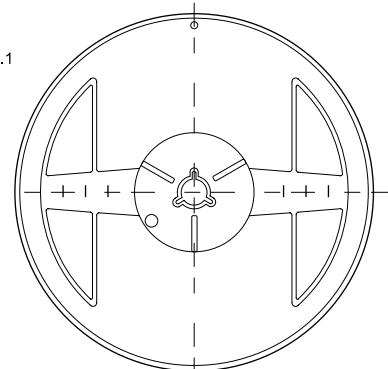
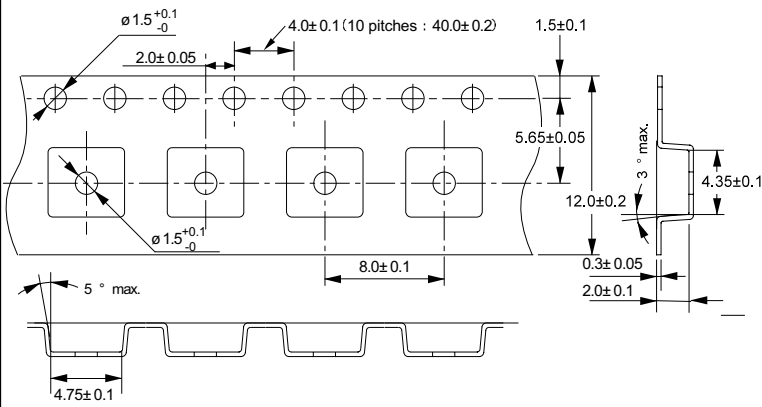

Winding core

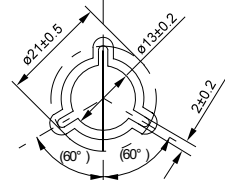

No. : UP003-A-C-SD-1.0

No. : UP003-A-R-SD-1.0

● TO-92

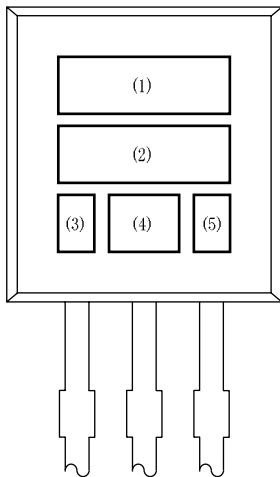

- (1) to (2) : Product name
- (3) : Year of assembly
- (4) : Month of assembly and week code
- (5) : Wafer lot No. (last digit)

No. : YF003-A-M-S1-1.0

● SC-82AB

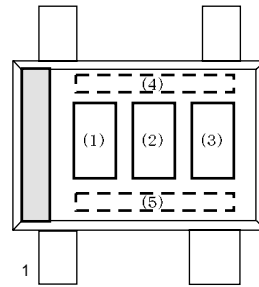

- (1) to (3) : Product name (abbreviation)
- (4) and (5) : Product lot

No. : NP004-A-M-S1-1.0

● SOT-23-5

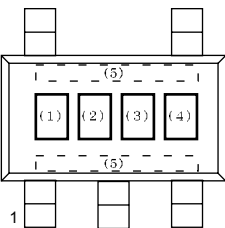

- (1) to (3) : Product name (abbreviation)
- (4) : Month of assembly
- (5) : Dot on one side  
(Year and week of assembly)

No. : MP005-A-M-S1-1.0

● SOT-89-3

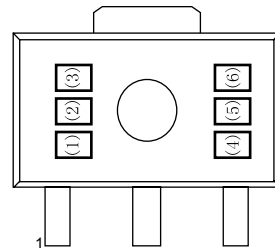

- (1) to (3) : Product name (abbreviation)
- (4) : Year of assembly
- (5) : Month of assembly
- (6) : Week of assembly

No. : UP003-A-M-S1-1.0

- The information herein is subject to change without notice.
- Seiko Instruments Inc. is not responsible for any problems caused by circuits or other diagrams described herein whose industrial properties, patents or other rights belong to third parties. The application circuit examples explain typical applications of the products, and do not guarantee any mass-production design.
- When the products described herein include Strategic Products (or Service) subject to regulations, they should not be exported without authorization from the appropriate governmental authorities.
- The products described herein cannot be used as part of any device or equipment which influences the human body, such as physical exercise equipment, medical equipment, security system, gas equipment, vehicle or airplane, without prior written permission of Seiko Instruments Inc.