

LOW VOLTAGE VERSATILE TELEPHONE TRANSMISSION CIRCUIT WITH DIALLER INTERFACE AND TRANSMIT LEVEL DYNAMIC LIMITING

GENERAL DESCRIPTION

The TEA1063 is a bipolar integrated circuit that performs all the speech and line interface functions required in fully electronic telephone sets. It performs electronic switching between dialling and speech and has a powerful DC supply for peripheral circuits. The IC operates at line voltages down to 1.6 V DC (with reduced performance) to facilitate the use of more telephone sets connected in parallel. The transmit signal on the line is dynamically limited (speech-controlled) to prevent distortion at high transmit levels of both the sending signal and the sidetone.

Features

- Low DC line voltage; operates down to 1.6 V (excluding polarity guard)
- Voltage regulator with low voltage drop and adjustable static resistance
- DC line voltage adjustment facility
- Provides a supply for external circuits in two options:
 - unregulated supply, regulated line voltage;
 - stabilized supply, line voltage varies with supply current
- Dynamic limiting (speech-controlled) in transmit direction prevents distortion of line signal and sidetone
- Symmetrical high-impedance inputs (64 k Ω) for dynamic, magnetic or piezo-electric microphones
- Asymmetrical high-impedance input (32 k Ω) for electret microphones
- DTMF signal input
- Confidence tone in the earpiece during DTMF dialling
- Mute input for disabling speech during pulse or DTMF dialling
- Power-down input for improved performance during pulse dial or register recall (flash)
- Receiving amplifier for magnetic, dynamic or piezo-electric earpieces
- Large amplification setting ranges on microphone and earpiece amplifiers
- Line loss compensation (line current dependent) for microphone and earpiece amplifiers (not used for DTMF amplifier)
- Gain control curve adaptable to exchange supply
- Automatic disabling of the DTMF amplifier in extremely-low voltage conditions

PACKAGE OUTLINES

TEA1063 : 20-lead DIL; plastic (SOT146).

TEA1063T: 20-lead mini-pack; plastic (SO20; SOT163A).

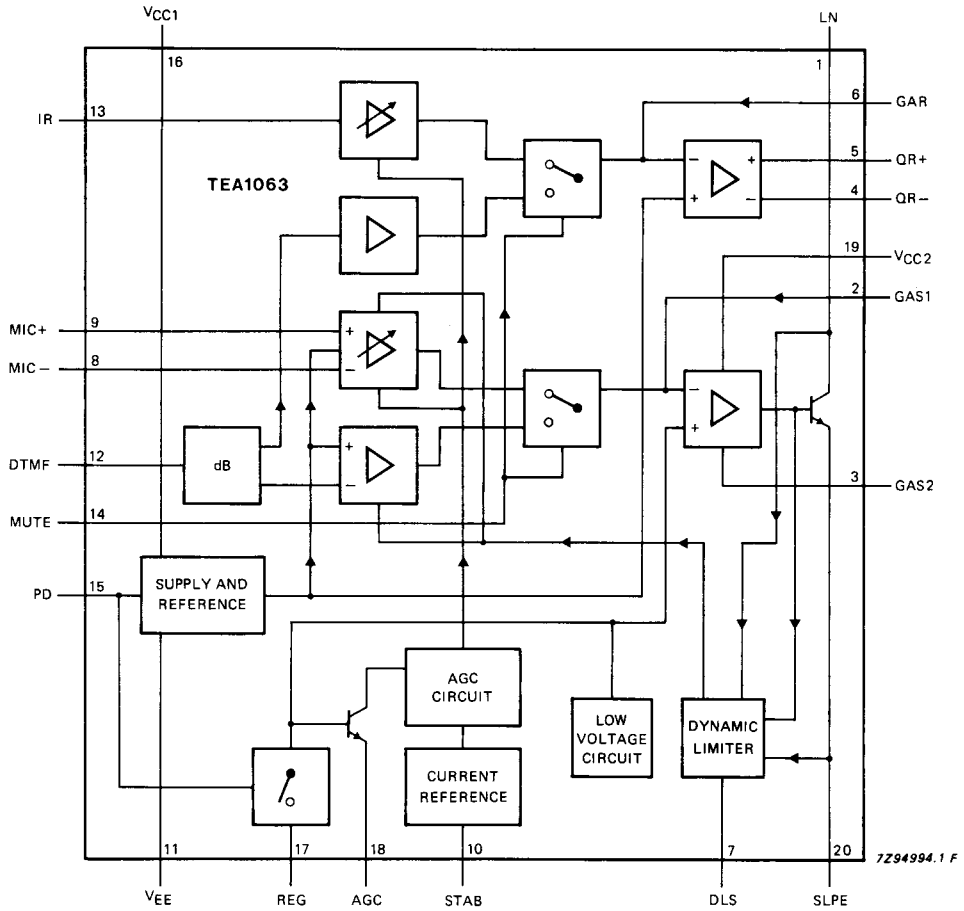

Fig. 1 Block diagram.

QUICK REFERENCE DATA

DEVELOPMENT DATA

parameter	conditions	symbol	min.	typ.	max.	unit
Operating ambient temperature range		T_{amb}	-25	-	+75	$^{\circ}C$
Line current operating range: normal operation		I_{line}	11	-	140*	mA
with reduced performance		I_{line}	2	-	11	mA
Internal supply current: power-down input LOW	$V_{CC1} = 3.1 V$	I_{CC1}	-	1.35	-	mA
power-down input HIGH	$V_{CC1} = 3.1 V$	I_{CC1}	-	60	-	μA
Voltage gain range: microphone amplifier		G_v	47	-	55	dB
receiving amplifier	Single ended	G_v	23	-	42	dB
	Differential	G_v	29	-	48	dB
Line loss compensation: gain control range		G_v	-	8.6	-	dB
exchange supply voltage range		V_{exch}	36	-	60	V
exchange feeding bridge resistance range		R_{exch}	400	-	1000	Ω
Maximum output voltage swing on LN (peak-to-peak value)	$R_{15} + R_{16} = 448 \Omega$ $I_{line} = 15 mA$ $I_p = 2 mA$ $I_p = 4 mA$	$V_{LN(p-p)}$ $V_{LN(p-p)}$	-	4.1 3.25	-	V V
<i>Regulated line voltage application</i>						
Supply for peripherals	$R_{15} = 0 \Omega$; $R_{16} = 392 \Omega$ $I_{line} = 15 mA$ $I_p = 1.65 mA$ $I_p = 1.8 mA$; $R_{REG-SLPE} = 68.1 k\Omega$	V_p V_p	2.7 3.0	- -	- -	V V
DC line voltage	$I_{line} = 15 mA$ without $R_{REG-SLPE}$ $R_{REG-SLPE} = 68.1 k\Omega$	V_{LN} V_{LN}	- -	4.0 4.3	- -	V V
<i>Stabilized supply voltage application</i>						
Supply for peripherals	$R_{15} = 392 \Omega$; $R_{16} = 56 \Omega$ $I_{line} = 15 mA$ $I_p = 0$ to 4 mA	$V_{CC2-SLPE}$	3.35	3.6	3.85	V
DC line voltage	$I_{line} = 15 mA$ $I_p = 2 mA$ $I_p = 4 mA$	V_{LN} V_{LN}	- -	4.8 5.5	- -	V V

* For TEA1063T the maximum line current depends on the heat dissipating qualities of the mounted device.

PINNING

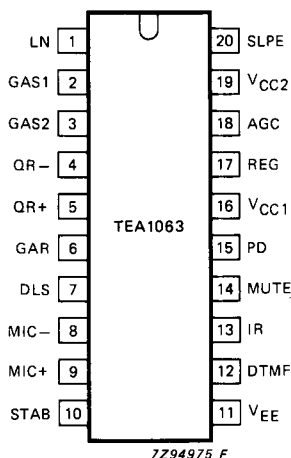

1	LN	positive line terminal
2	GAS1	gain adjustment; transmitting amplifier
3	GAS2	gain adjustment; transmitting amplifier
4	QR-	inverting output, receiving amplifier
5	QR+	non-inverting output, receiving amplifier
6	GAR	gain adjustment; receiving amplifier
7	DLS	decoupling for transmit amplifier dynamic limiter
8	MIC-	inverting microphone input
9	MIC+	non-inverting microphone input
10	STAB	current stabilizer
11	V _{EE}	negative line terminal
12	DTMF	dual-tone multi-frequency input
13	IR	receiving amplifier input
14	MUTE	mute input
15	PD	power-down input
16	V _{CC1}	internal supply decoupling
17	REG	voltage regulator decoupling
18	AGC	automatic gain control input
19	V _{CC2}	reference voltage with respect to SLPE
20	SLPE	slope adjustment for DC curve/reference for peripheral circuits

Fig. 2 Pinning diagram.

FUNCTIONAL DESCRIPTION

Supplies V_{CC1}, V_{CC2}, LN, SLPE, REG and STAB (Fig. 3)

Power for the TEA1063 and its peripheral circuits is usually obtained from the telephone line. The IC develops its own supply voltage at V_{CC1} and regulates its voltage drop. The internal supply requires a decoupling capacitor between V_{CC1} and V_{EE}. The internal current stabilizer is set by a 3.6 k Ω resistor between STAB and V_{EE}.

The DC current flowing into the set is determined by the exchange supply voltage V_{exch}, the feeding bridge resistance R_{exch}, the subscriber line DC resistance R_{line} and the DC voltage (including polarity guard) on the subscriber set (see Fig. 3).

The internal voltage regulator generates a temperature-compensated reference voltage that is available between V_{CC2} and SLPE [V_{ref} = V_{CC2}-SLPE = 3.6 V (typ.)]. This internal voltage regulator requires decoupling by a capacitor between REG and V_{EE} (C3).

The reference voltage can be used to:

- regulate directly the line voltage (stabilized V_{LN-SLPE} = V_{CC2-SLPE})
- to stabilize the supply voltage for peripherals.

Regulated line voltage

In this application the V_{CC2} pin is connected to the LN pin as shown in Fig. 3. This configuration gives a stabilized voltage across pins LN and SLPE which, applied via the low-pass filter R16, C15, provides a supply to the peripherals that is independent of the line current and depends only on the peripheral supply current.

The value of R16 and the level of the DC voltage V_{LN-SLPE} determine the supply capabilities. In the basic application R16 = 392 Ω and C15 = 220 μ F. The worst-case peripheral supply current as a function of supply voltage is shown in Fig. 4. To increase the supply capabilities, the DC voltage V_{LN-SLPE} can be increased by using R_{VA}(REG-SLPE) or by decreasing the value of R16.

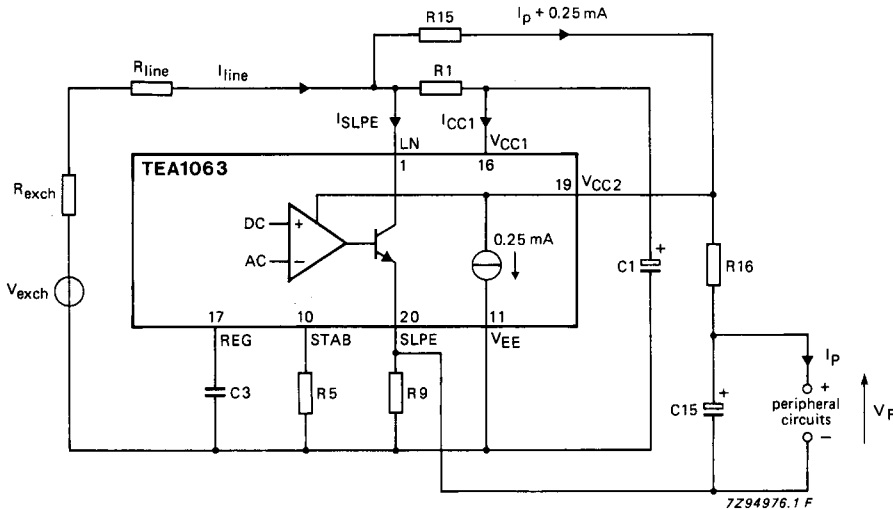

Fig. 3 Application with regulated line voltage (stabilized $V_{LN-SLPE}$). The voltage $V_{LN-SLPE}$ is fixed to $V_{ref} = 3.6 \pm 0.25$ V. Resistor R16 together with the line current determine the supply capabilities and the maximum output swing on the line (no loop damping is necessary). The line voltage $V_{LN} = V_{ref} + ([I_{line} - I_{CC1} - 0.25 \text{ mA}] \times R9)$.

DEVELOPMENT DATA

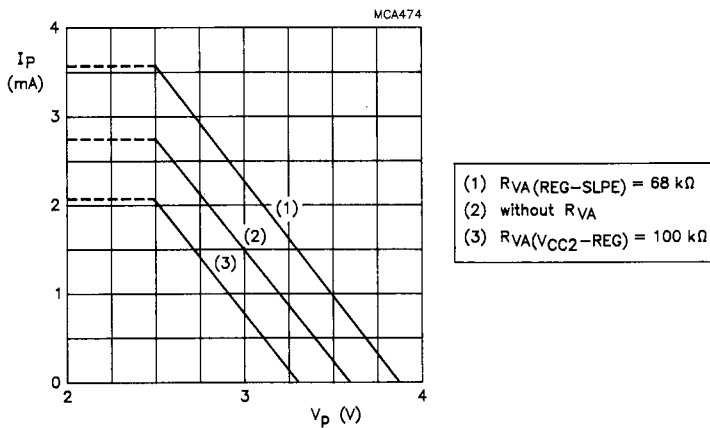

Fig. 4 Minimum supply current for peripherals (I_P) as a function of the peripheral supply voltage (V_P): $I_{line} = 15$ mA; $R16 = 392 \Omega$; $R15 = 0 \Omega$; valid for MUTE = 0 and 1. Line current has very little influence.

FUNCTIONAL DESCRIPTION (continued)*Regulated line voltage* (continued)

The maximum AC output swing on the line at low line currents is influenced by R16 (limited by current) and the maximum output swing on the line at high line currents is influenced by the DC voltage $V_{LN-SLPE}$ (limited by voltage). In both these situations, the internal dynamic limiter in the sending channel prevents distortion when the microphone input is overdriven. The maximum AC output swing on LN is shown in Fig. 5; practical values for R16 are from 200 to 600 Ω and this influences both the maximum output swing at low line currents and the supply capabilities.

The SLPE pin is the ground reference for peripheral circuits, therefore inputs MUTE, PD and DTMF are also referenced to SLPE.

Active microphones can be supplied between V_{CC1} and V_{EE} . Low-power circuits that provide only MUTE and/or PD inputs to the TEA1063 also can be powered from V_{CC1} . However V_{CC1} cannot be used for circuits that provide DTMF signals to the TEA1063 because V_{CC1} is referred to ground.

If the line current I_{line} exceeds $I_{CC1} + 0.25$ mA, the voltage converter shunts the excess current to SLPE via LN; where $I_{CC1} \approx 1.35$ mA, the value required by the IC for normal operation.

The DC line voltage on LN is:

$$V_{LN} = V_{LN-SLPE} + (I_{SLPE} \times R9)$$

$$V_{LN} = V_{ref} + ((I_{line} - I_{CC1} - 0.25 \times 10^{-3}) \times R9)$$

in which

$V_{ref} = 3.6$ V \pm 0.25 V is the internal reference voltage between V_{CC2} and SLPE; its value can be adjusted by external resistor R_{VA}

$R9$ = external resistor between SLPE and V_{EE} (20 Ω in basic application).

With $R9 = 20$ Ω , this results in:

$$V_{LN} = 3.85 \pm 0.25$$
 V at $I_{line} = 15$ mA

$$V_{LN} = 4.15 \pm 0.3$$
 V at $I_{line} = 15$ mA, $R_{VA}(REG-SLPE) = 68.1$ k Ω

$$V_{LN} = 3.55 \pm 0.3$$
 V at $I_{line} = 15$ mA, $R_{VA}(V_{CC2} - REG) = 100$ k Ω ;

The preferred value for R9 is 20 Ω . Changing R9 influences microphone gain, DTMF gain, the gain control characteristics, sidetone, and the DC characteristics (especially the low voltage characteristics).

In normal conditions, $I_{SLPE} \gg (I_{CC1} + 0.25$ mA) and the static behaviour is equivalent to a voltage regulator diode with an internal resistance of R9. In the audio frequency range the dynamic impedance is determined mainly by R1. The equivalent impedance of the circuit in the audio frequency range is shown in Fig. 6.

The internal reference voltage $V_{CC2-SLPE}$ can be increased by external resistor $R_{VA}(REG-SLPE)$ connected between REG and SLPE or decreased by external resistor $R_{VA}(V_{CC2} - REG)$ connected between V_{CC2} and REG. The supply voltage $V_{CC2-SLPE}$ is shown as a function of R_{VA} in Fig.7. Changing the reference voltage influences the output swing of both sending and receiving amplifiers.

At line currents below 10 mA (typ.), the DC voltage dropped across the circuit is adjusted to a lower level automatically (approximately 1.6 V at 2 mA). This gives the possibility of operating more telephone sets in parallel with DC line voltages (excluding polarity guard) down to an absolute minimum of 1.6 V. At line currents below 10 mA (typ.), the circuit has limited sending and receiving levels.

DEVELOPMENT DATA

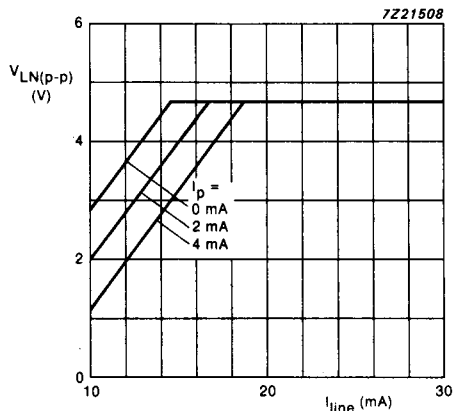

Fig. 5 Maximum AC output swing on the line as a function of line current with peripheral supply current as a parameter: $R_{15} = 0 \Omega$; $R_{16} = 392 \Omega$.

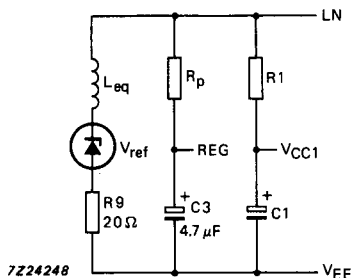

Fig. 6 Equivalent impedance between LN and V_{EE} in the application with stabilized $V_{LN-SLPE}$:

$R_{15} = 0 \Omega$
 $L_{eq} = C_3 \times R_9 \times R_p$
 $R_p = 15 \text{ k}\Omega$.

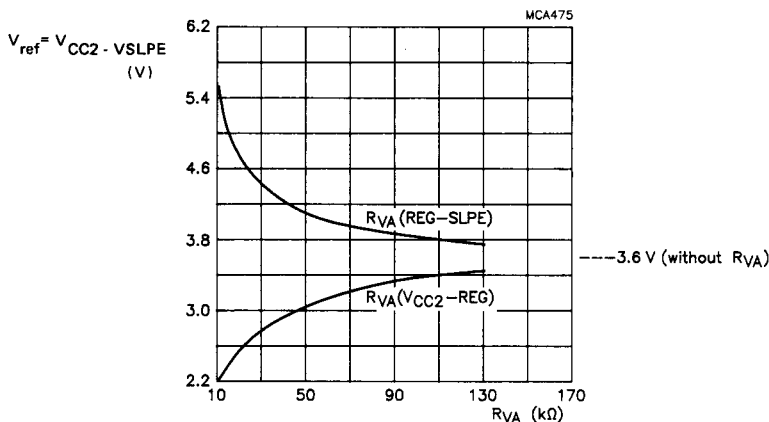

Fig. 7 Internal reference voltage $V_{CC2-SLPE}$ as a function of resistor $R_{VA}(REG-SLPE)$ for line currents between 11 and 140 mA.

In the stabilized peripheral supply voltage application;

$$V_{LN} = V_{CC2-SLPE} + ([I_p + 0.25 \times 10^{-3}] \times R_{15}) + ([I_{line} - I_{CC1} - 0.25 \text{ mA}] \times R_9) \text{ V}$$

In the regulated line voltage application ($R_{15} = 0 \Omega$);

$$V_{LN} = V_{CC2-SLPE} + ([I_{line} - I_{CC1} - 0.25 \text{ mA}] \times R_9) \text{ V}$$

FUNCTIONAL DESCRIPTION (continued)*Stabilized peripheral supply voltage*

The configuration shown in Fig. 8 provides a stabilized voltage across pins V_{CC2} and $SLPE$ for peripheral circuits (such as dialling and control circuits); the DC voltage V_{LN} now varies with the peripheral supply current.

The V_{CC2} - $SLPE$ supply must be decoupled by capacitor $C15$. For stable loop operation, resistor $R16$ ($\approx 50 \Omega$) is connected between V_{CC2} and $SLPE$ in series with $C15$. The voltage regulator control loop is completed by resistor $R15$ between LN and V_{CC2} .

For sets with an impedance of 600Ω , practical values are: $R15 = 200$ to 600Ω ; $C15 = 220 \mu F$; $C3 = 470$ nF. The ratio $R15/R16 \leq 8$ is for stable loop operation with sufficient phase margin, and $R15/R16 \geq 6$ is for satisfactory set impedance in the audio frequency range.

For sets with complex impedance, the value of $C3$ and the ratio $R15/R16$ are different.

The peripheral supply capability depends mainly on the available line current, the required AC output swing on the line, the maximum permitted DC voltage on the line and the values of external components (especially $R15$). With $R15 = 392 \Omega$ and $R16 = 56 \Omega$ (basic application) the maximum possible AC output swing on the line as a function of line current is as shown in Fig. 9, the curve parameter is the peripheral supply current (I_p). Different values for $R15$ (from 200 to 600Ω) maintaining $6 < R15/R16 < 8$ give different results.

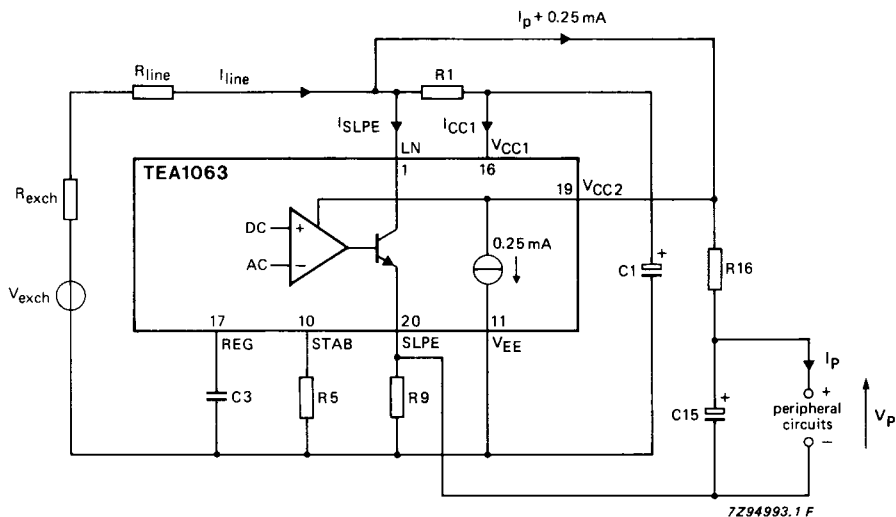

Fig. 8 Application with stabilized supply voltage for peripheral circuits: $R15 = 392 \Omega$; $R16 = 56 \Omega$.

The DC line voltage on LN is

$$V_{LN} = V_{LN-SLPE} + (I_{SLPE} \times R9).$$

Therefore

$$V_{LN} = V_{ref} + ([I_p + 0.25 \times 10^{-3}] \times R15) + ([I_{line} - I_{CC1} - 0.25 \times 10^{-3}] \times R9)$$

in which:

V_{ref} is the internal reference voltage between V_{CC2} and SLPE (the value of V_{ref} can be adjusted by an external resistor, R_{VA}). $V_{ref} = 3.6$ V (typ.) without R_{VA}

I_p is the supply current used by peripheral circuits

R15 is an external resistor between LN and V_{CC2} (392 Ω in the basic application)

R9 is an external resistor between SLPE and V_{EE} (20 Ω in the basic application)

DEVELOPMENT DATA

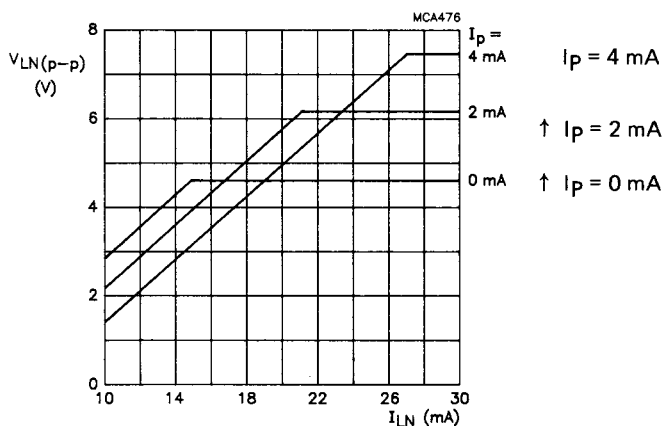

Fig. 9 Maximum output swing on line as a function of line current with the peripheral supply current as a parameter; R15 = 392 Ω ; R16 = 56 Ω . As different values of R15 and R16 are allowed, different curves would then apply.

The DC voltage $V_{LN-SLPE}$ as a function of I_p with R15 as a parameter is shown in Fig. 10. In the audio frequency range, the dynamic impedance is determined mainly by R1. The equivalent impedance in the audio range of the circuit (Fig. 8) is shown in Fig. 11.

FUNCTIONAL DESCRIPTION (continued)

Stabilized peripheral supply voltage (continued)

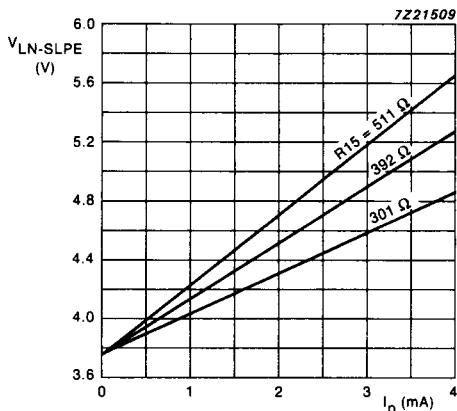
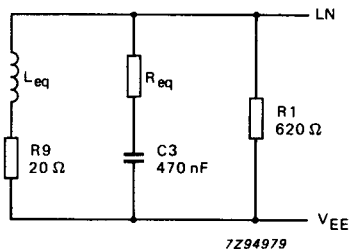

Fig. 10 Curves showing the typical voltage drop between LN and SLPE as a function of the supply current for peripherals with R15 as a parameter: $V_{CC2-SLPE} = 3.6\text{ V}$ (R_{VA} not connected). $V_{CC2-SLPE}$ can be adjusted between approximately 2.6 and 5 V by changing the value of R_{VA} , this results in a parallel-shift of the curves.

The total voltage drop $V_{LN} \approx V_{LN-SLPE} + ([I_{line} - I_{CC1} - 0.25\text{ mA}] \times R_9)$



$$R_{eq} = R_p \left(\frac{R_{15}}{R_{16}} + 1 \right)$$

$$L_{eq} = C_3 \times R_9 \times R_{eq}$$

with $R_p = 15\text{ k}\Omega$

Fig. 11 Equivalent impedance between LN and V_{EE} at $f > 300\text{ Hz}$ in the application with stabilized supply voltage for peripheral circuits.

Microphone inputs MIC+ and MIC- and gain pins GAS1 and GAS2

The TEA1063 has symmetrical microphone inputs, its input impedance is $64\text{ k}\Omega$ ($2 \times 32\text{ k}\Omega$) and its voltage amplification is typ. 55 dB with $R_7 = 68\text{ k}\Omega$. Either dynamic, magnetic or piezo-electric microphones can be used, or an electret microphone with a built-in FET buffer. Arrangements for the microphone types are shown in Fig. 12.

The gain of the microphone amplifier is proportional to external resistor R7 connected between GAS1 and GAS2 and with this it can be adjusted between 47 dB and 55 dB to suit the sensitivity of the transducer.

An external 100 pF capacitor (C6) is required between GAS1 and SLPE to ensure stability. A larger value of C6 may be chosen to obtain a first-order low-pass filter with a cut-off frequency corresponding to the time constant $R_7 \times C_6$.

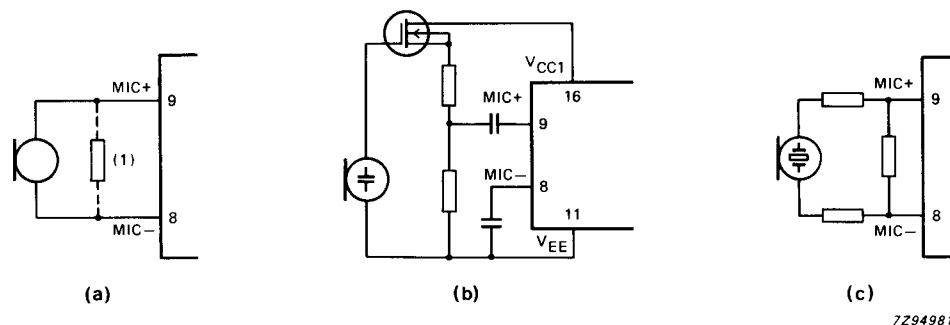

Fig. 12 Microphone arrangements: a) magnetic or dynamic microphone, the resistor (1) may be connected to reduce the terminating impedance, or for sensitive types a resistive attenuator can be used to prevent overloading the microphone inputs; b) electret microphone; c) piezo-electric microphone.

Dynamic limiter (sending) pin DLS

To prevent distortion of the transmitted signal, the gain of the microphone amplifier is reduced rapidly when peaks of the signal on the line exceed an internally-determined threshold. The time in which gain reduction is effected (attack time) is very short. The circuit stays in the gain-reduced condition until the peaks of the sending signal remain below the threshold level. The microphone gain then returns to normal after a time determined by the capacitor connected to DLS (release time).

The internal threshold adapts automatically to the DC voltage setting of the circuit (voltage $V_{LN-SLPE}$). This means that the maximum output swing on the line will be higher if the DC voltage dropped across the circuit is increased.

Fig. 13 shows the maximum possible output swing on the line as a function of the DC voltage drop ($V_{LN-SLPE}$) with $I_{line} - I_p$ as a parameter.

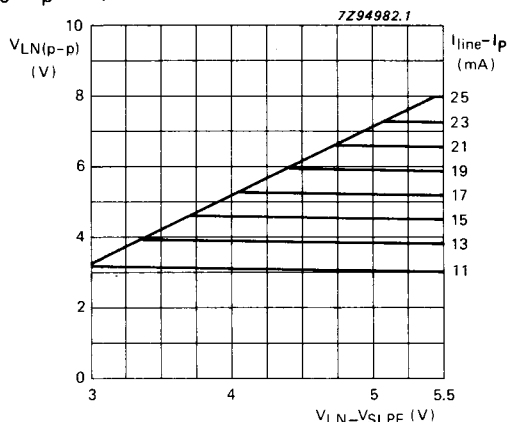

Fig. 13 Maximum output swing on line as a function of the DC voltage drop $V_{LN-SLPE}$ with $I_{line} - I_p$ as a parameter: $R_{15} = 392 \Omega$; $R_{16} = 56 \Omega$; or $R_{15} = 0 \Omega$ and $R_{16} = 392 + 56 = 448 \Omega$.

The internal threshold level is lowered automatically if the DC current in the transmit output stage is insufficient. This prevents distortion of the sending signal in applications using parallel-connected telephones or telephones operating over long lines, for example.

Dynamic limiting also considerably improves sidetone performance in over-drive conditions (less distortion; limited sidetone level).

DEVELOPMENT DATA

FUNCTIONAL DESCRIPTION (continued)

Receiving amplifier IR, QR+, QR– and GAR

The receiving amplifier has one input IR and two complementary outputs, QR+ (non-inverting) and QR– (inverting). These outputs may be used for single-ended or differential drive, depending on the type and sensitivity of the earpiece used (see Fig. 14). Gain from IR to QR+ is typically 34 dB with $R_4 = 100\text{ k}\Omega$, sufficient for low-impedance magnetic or dynamic earpieces which are suitable for single-ended drive. By using both outputs (differential drive) the gain is increased by 6 dB. Differential drive can be used when the earpiece impedance exceeds $450\ \Omega$ as with high-impedance dynamic, magnetic or piezo-electric earpieces.

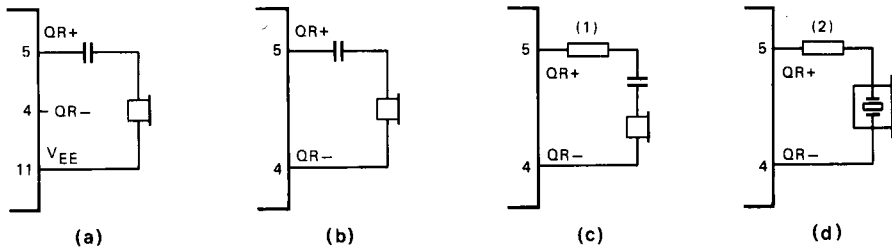

7Z94983

Fig. 14 Alternative receiver arrangements: a) dynamic earpiece with an impedance less than $450\ \Omega$; b) dynamic earpiece with an impedance more than $450\ \Omega$; c) magnetic earpiece with an impedance more than $450\ \Omega$, resistor (1) may be connected to prevent distortion (inductive load); d) piezo-electric earpiece, resistor (2) is required to increase the phase margin (stability with capacitive load).

The output voltage of the receiving amplifier is specified for continuous-wave drive. Fig. 15 shows the maximum output swing of the receiving amplifier as a function of the DC voltage drop (V_{LN}). The maximum output voltage will be higher under speech conditions, where the ratio of the peak to the RMS value is higher.

The gain of the receiving amplifier can be adjusted to suit the sensitivity of the transducer used. The adjustment range is between 23 dB and 42 dB with single-ended drive and between 29 dB and 48 dB with differential drive. The gain is proportional to the external resistor R_4 connected between GAR and QR+. The overall gain between LN and QR+ can be found by subtracting the attenuation of the anti-sidetone network (32 dB) from the amplifier gain.

Two external capacitors ($C_4 = 100\text{ pF}$ and $C_7 = 10 \times C_4 = 1\text{ nF}$) ensure stability. A larger value may be chosen to obtain a first-order low-pass filter. The cut-off frequency corresponds with the time constant $R_4 \times C_4$. The relationship $C_7 = 10 \times C_4$ must be maintained.

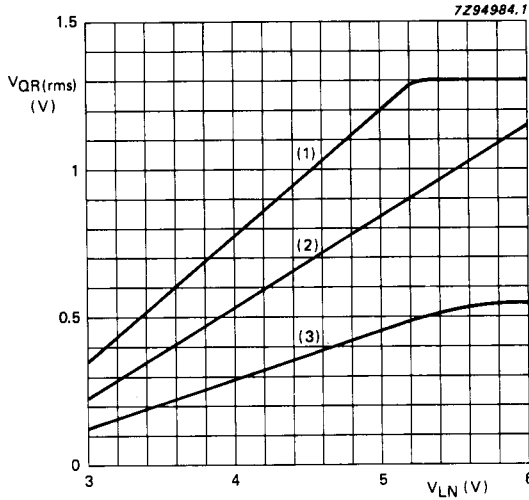

Fig. 15 Maximum output swing of the receiving amplifier as a function of DC voltage drop V_{LN} with the load at the receiver output as parameter; valid for both supply options; THD = 2%; $I_{line} = 15$ mA. Curve (1) is for a differential load of 47 nF (series resistance = 100 Ω); $f = 3400$ Hz. Curve (2) is for a differential load of 450 Ω ; $f = 1$ kHz. Curve (3) is for a single-ended load of 150 Ω ; $f = 1$ kHz.

Automatic gain control input AGC

Automatic compensation of line loss is obtained by connecting a resistor (R_6) between AGC and V_{EE} . This automatic gain control varies the gain of the microphone amplifier and receiving amplifier in accordance with the DC line current. The control range is 9 dB; this corresponds to a 5 km line of 0.4 mm diameter copper twisted-pair cable (DC resistance = 280 Ω /km, average attenuation = 1.8 dB/km). The DTMF gain is not affected by this feature.

The value of R_6 must be chosen with reference to the exchange supply voltage and its feeding bridge resistance (see Fig. 16 and Table 1). Different values of R_6 give the same line current ratios at the start and the end of the control range. If automatic line-loss compensation is not required the AGC pin can be left open, the amplifiers then give their maximum adjusted gain.

DEVELOPMENT DATA

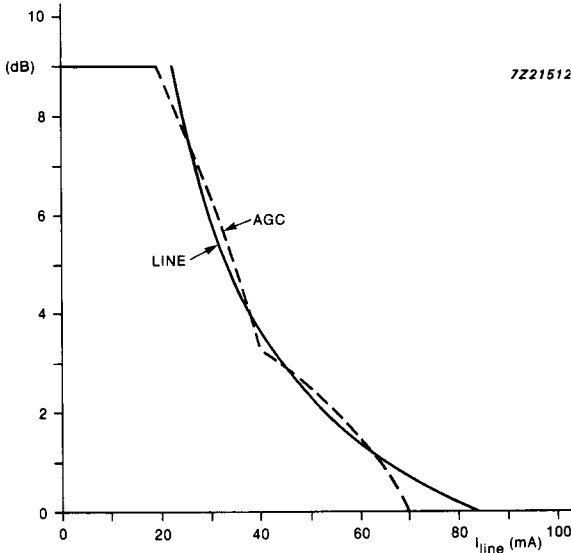

Fig. 16 Variation of amplification as a function of line current with R_6 as a parameter; $R_9 = 20$ Ω .

* Value to be fixed.

FUNCTIONAL DESCRIPTION (continued)**Automatic gain control input AGC** (continued)**Table 1** Values of R6 giving optimum line-loss compensation at various values of exchange supply voltage (V_{exch}) and exchange feeding bridge resistance (R_{exch}); $R_9 = 20 \Omega$.

		$R_{exch} (\Omega)$				
		400	500	600	800	1000
V_{exch} (V)		$R_6 (k\Omega)$				
		36	41.2 K	37.5 K	32.4 K	X
48	56.2 K	51 k Ω	47.5 K	40.2 K	X	
60	X	X	59 K	52.3 K	46.4 K	

MUTE input (see notes 1 and 2)

MUTE = HIGH enables the DTMF input and inhibits the microphone and receiving amplifier inputs.

MUTE = LOW or open-circuit disables the DTMF input and enables the microphone and receiving amplifier inputs.

Switching MUTE gives negligible clicks at the telephone outputs and on the line.

The MUTE function is operational down to $V_{LN} = 2.8 \text{ V}$ ($V_{CC1} = 2.1 \text{ V}$). It is not possible to enable the DTMF amplifier for $V_{LN} < 2.8 \text{ V}$, in this way the optimum performance of the speech amplifiers is guaranteed under extremely low voltage conditions (parallel operation). The speech amplifiers can be disabled by means of the MUTE function down to $V_{LN} = 1.6 \text{ V}$.

Dual-tone multi-frequency input DTMF (see note 1)

When the DTMF input is enabled, dialling tones may be sent on to the line. The voltage gain between DTMF-SLPE and LN- V_{EE} is typ. 29 dB less than the gain of the microphone amplifier and varies with R7 in the same way as the gain of the microphone amplifier. This means that the tone level at the DTMF input has to be adjusted after setting the gain of the microphone amplifier.

With $R_7 = 68 \text{ k}\Omega$ the gain is typically 26 dB.

The signalling tones can be heard in the earpiece at a low level (confidence tone).

Power-down input PD (see notes 1 and 2)

During pulse dialling or register recall (timed loop break) the telephone line is interrupted; as a consequence it provides no supply for the transmission circuit connected to V_{CC1} or for the peripherals between V_{CC2} and SLPE.

These supply gaps are bridged by the charges in the capacitors C1 and C15. The requirements on these capacitors are eased by applying a HIGH level to the PD input during the time of the loop break. This reduces the internal supply current I_{CC1} from (typ.) 1.3 mA to (typ.) 60 μA and switches off the voltage regulator to prevent discharge via LN and V_{CC2} .

A HIGH level at PD also internally disconnects the capacitor at REG so that the voltage stabilizer has no switch-on delay after line interruptions. This minimizes the contribution of the IC to the current waveform during pulse dialling or register recall.

When the power-down facility is not required, the PD pin can be left open-circuit or connected to SLPE.

Side-tone suppression

Suppression of the transmitted signal in the earpiece is obtained by the anti-sidetone network comprising $R1//Z_{line}$, $R2$, $R3$, $R8$, $R9$ and Z_{bal} (see Fig. 17). Maximum compensation is obtained when the following conditions are fulfilled:

- a) $R9 \times R2 = R1 \times (R3 + [R8//Z_{bal}])$
- b) $(Z_{bal}/[Z_{bal} + R8]) = (Z_{line}/[Z_{line} + R1])$

If fixed values are chosen for $R1$, $R2$, $R3$ and $R9$, then condition a) is always fulfilled provided $|R8//Z_{bal}| \ll R3$.

To obtain optimum sidetone suppression, condition b) has to be fulfilled, resulting in:

$$Z_{bal} = (R8/R1) \times Z_{line} = k \times Z_{line}$$

where k is a scale factor; $k = (R8/R1)$.

The scale factor k (value of $R8$) is chosen to meet the following criteria:

- compatibility with a standard capacitor from the E6 or E12 range for Z_{bal} ;
- $|Z_{bal}//R8| \ll R3$ to fulfill condition a) and thus ensure correct anti-sidetone bridge operation;
- $|Z_{bal} + R8| \gg R9$ to avoid influencing the transmit gain.

In practice Z_{line} varies considerably with the line length and line type. Therefore the value chosen for Z_{bal} should be for an average line length giving satisfactory sidetone suppression with short and long lines. The suppression also depends on the accuracy of the match between Z_{bal} and the impedance of the average line.

Example

The line impedance for which optimum suppression is to be obtained can be represented by $210 \Omega + (1265 \Omega // 140 \text{ nF})$. This represents a 5 km line of 0.5 mm diameter copper twisted-pair cable matched with 600Ω ($176 \Omega/\text{km}$; $38 \text{ nF}/\text{km}$).

With $k = 0.64$ this results in: $R8 = 390 \Omega$; $Z_{bal} = 130 \Omega + (820 \Omega // 220 \text{ nF})$.

The anti-sidetone network for the TEA1060 family shown in Fig. 17 attenuates the signal received from the line by 32 dB before it enters the receiving amplifier. The attenuation is almost constant over the whole audio-frequency range.

Alternatively a conventional Wheatstone bridge can be used as an anti-sidetone circuit (Fig. 18). Both bridge types can be used with either resistive or complex set impedances. (More information on the balancing of anti-sidetone bridges can be obtained in our publication 'Versatile speech transmission ICs for electronic telephone sets', order number 9398 341 10011.)

Notes

1. The reference used for the MUTE, DTMF and PD inputs is SLPE.
2. A LOW level for any of these pins is defined by connection to SLPE, a HIGH level is defined as a voltage greater than $V_{SLPE} + 1.5 \text{ V}$ and smaller than $V_{CC1} + 0.4 \text{ V}$.

Side-tone suppression (continued)

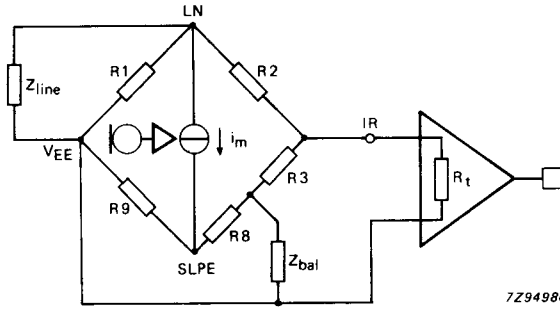

Fig. 17 Equivalent circuit of TEA1060 family anti-side-tone bridge.

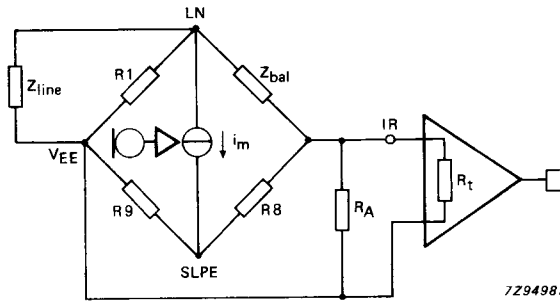

Fig. 18 Equivalent circuit of an anti-sidetone network in the Wheatstone bridge configuration.

RATINGS

Limiting values in accordance with the Absolute Maximum System (IEC 134)

parameter	conditions	symbol	min.	max.	unit
Positive line voltage continuous		V_{LN}	—	12	V
Repetitive line voltage during switch-on or line interruption		V_{LN}	—	13.2	V
Repetitive peak line voltage; one 1 ms pulse per 5 s	$R9 = 20 \Omega$; $R10 = 13 \Omega$ (Fig. 23)	V_{LN}	—	28	V
Line current TEA1063 (1)		I_{line}	—	140	mA
Line current TEA1063T (1)		I_{line}	—	140	mA
Input voltage on pins other than LN and V_{CC2}		V_i	$V_{EE} - 0.7$	$V_{CC1} + 0.7$	V
Total power dissipation (2)	$Rg = 20 \Omega$	P_{tot}	—	715	mW
TEA1063		P_{tot}	—	550	mW
TEA1063T					
Storage temperature range		T_{stg}	-40	+125	°C
Operating ambient temperature range		T_{amb}	-25	+75	°C
Junction temperature		T_j	—	+125	°C

DEVELOPMENT DATA

1. The value depends mostly on the maximum required T_{amb} and on the voltage between LN and SLPE (see Figs 19 and 20) to determine the current as a function of the required voltage and temperature.
2. Calculated for maximum $T_{amb} = 75 \text{ }^\circ\text{C}$ and a maximum junction temperature of 125 °C.

THERMAL RESISTANCE

From junction to ambient in free air

TEA1063	$R_{th j-a}$	typ.	70 K/W
TEA1063T mounted on glass epoxy boards 41 x 19 x 1.5 mm	$R_{th j-a}$	typ.	90 K/W

CHARACTERISTICS

$I_{line} = 11$ to 140 mA; $V_{EE} = 0$ V; $f = 800$ Hz; $T_{amb} = 25$ °C; $R_I = 600$ Ω; tested in the circuit of Fig. 21 or 22); unless otherwise specified.

parameter	conditions	symbol	min.	typ.	max.	unit
Supplies LN, V_{CC1}, V_{CC2} (pins 1, 16, 19)						
Reference DC voltage between V _{CC2} and SLPE	$I_{line} = 15$ mA $I_p = 0$; 4 mA					
R_{VA} not connected		V _{CC2-SLPE}	3.35	3.6	3.85	V
Variation with temperature	$I_{line} = 15$ mA	$\frac{\Delta V_{CC2-SLPE}}{\Delta T}$	-2	-1	1	mV/K
Variation with line current referred to 15 mA	$I_{line} = 100$ mA	$\Delta V_{CC2-SLPE}$	-	40	-	mV
With R_{VA} connected between REG and SLPE	$R_{VA} = 68.1$ kΩ	V _{CC2-SLPE}	3.6	3.9	4.2	V
between REG and LN	$R_{VA} = 100$ kΩ	V _{CC2-SLPE}	3.0	3.3	3.6	V
DC line voltage: voltage drop between LN and V _{EE}						
	MIC-, MIC+ inputs open; $R_{15} = 392$ Ω; without R_{VA}					
at $I_{line} = 15$ mA	$I_p = 0$ mA	V _{LN}	3.7	4.0	4.3	V
	$I_p = 2$ mA	V _{LN}	4.5	4.8	5.1	V
	$I_p = 4$ mA	V _{LN}	5.2	5.5	5.8	V
at $I_{line} = 100$ mA	$I_p = 2$ mA	V _{LN}	-	6.5	7.1	V
at $I_{line} = 140$ mA	$I_p = 2$ mA	V _{LN}	-	7.25	8.1	V
Voltage drop under low current conditions						
	$I_p = 0$ mA					
	$I_{line} = 2$ mA	V _{LN}	-	1.8	-	V
	$I_{line} = 4$ mA	V _{LN}	1.8	2.1	2.4	V
	$I_{line} = 7$ mA	V _{LN}	2.5	2.8	3.1	V
	$I_{line} = 11$ mA	V _{LN}	3.6	3.9	4.2	V
Internal supply current I _{CC1} : current into pin V _{CC1}						
	V _{CC1} = 3.1 V					
	PD = LOW	I _{CC1}	-	1.35	1.65	mA
	PD = HIGH	I _{CC1}	-	60	90	μA
Microphone inputs MIC-, MIC+ (pins 8, 9)						
Input impedance:						
differential		Z _i	51	64	77	kΩ
single-ended		Z _i	25.5	32.0	38.5	kΩ

DEVELOPMENT DATA

parameter	conditions	symbol	min.	typ.	max.	unit
Common mode rejection ratio		CMRR	—	82	—	dB
Voltage gain (see Fig. 21)	$I_{line} = 15 \text{ mA};$ $R7 = 68 \text{ k}\Omega$	G_V	54	55	56	dB
Variation of G_V with frequency, referred to 0.8 kHz	$f = 300 \text{ and } 3400 \text{ Hz}$	ΔG_{Vf}	-0.5	± 0.15	+0.5	dB
Variation of G_V with temperature, referred to 25 °C	without R6; $I_{line} = 50 \text{ mA};$ $T_{amb} = -25 \text{ and } +75 \text{ }^\circ\text{C}$	ΔG_{VT}	—	± 0.2	—	dB
DTMF input (pin 12)						
Input impedance		Z_i	16.1	20.0	23.9	k Ω
Voltage gain (see Fig. 21)	$I_{line} = 15 \text{ mA};$ $R7 = 68 \text{ k}\Omega$	G_V	25	26	27	dB
Variation of G_V with frequency, referred to 0.8 kHz	$f = 300 \text{ and } 3400 \text{ Hz}$	ΔG_{Vf}	-0.5	± 0.1	+0.5	dB
	$f = 697 \text{ and } 1633 \text{ Hz}$	ΔG_{Vf}	-0.2	± 0.05	+0.2	dB
Variation of G_V with temperature, referred to 25 °C	$I_{line} = 50 \text{ mA};$ $T_{amb} = -25 \text{ and } +75 \text{ }^\circ\text{C}$	ΔG_{VT}	—	± 0.2	—	dB
Gain adjustment inputs GAS1, GAS2 (pins 2, 3)						
Transmitting amplifier, gain adjustment range		ΔG_V	-8	—	+0	dB
Sending amplifier output LN (pin 1)						
<i>Dynamic limiter</i>						
Output voltage swing (peak-to-peak value)	$I_{line} = 15 \text{ mA};$ $R7 = 68 \text{ k}\Omega;$ $I_p = 0 \text{ mA};$ $V_i(\text{rms}) = 2.9 \text{ mV}$	$V_{LN(p-p)}$	4.15	4.55	4.95	V
Total harmonic distortion	$V_i = 2.9 \text{ mV} + 10 \text{ dB}$	THD	—	1.0	2.0	%
	$V_i = 2.9 \text{ mV} + 15 \text{ dB}$	THD	—	2.5	10.0	%
Output voltage swing (peak-to-peak value)	$V_i = 2.9 \text{ mV} + 10 \text{ dB}$					
	$I_p = 2 \text{ mA}$	$V_{LN(p-p)}$	3.7	3.95	4.25	V
	$I_p = 4 \text{ mA}$	$V_{LN(p-p)}$	3.0	3.25	3.5	V
	$I_p = 0 \text{ mA};$ $I_{line} = 7 \text{ mA}$	$V_{LN(p-p)}$	—	2.0	—	V
	$I_p = 0 \text{ mA};$ $I_{line} = 5 \text{ mA}$	$V_{LN(p-p)}$	—	1.45	—	V

CHARACTERISTICS (continued)

parameter	conditions	symbol	min.	typ.	max.	unit
LN output (continued)						
Dynamic behaviour of limiter						
C16 = 470 nF						
attack time, V_{mic} jumps from 2 mV to 40 mV		t_{att}	—	1.5	5.0	ms
release time, V_{mic} falls from 40 mV to 2 mV		t_{rel}	50	150	—	ms
Noise output voltage (RMS value)	$I_{line} = 15$ mA; R7 = 68 k Ω ; 200 Ω between MIC– and MIC+; psophometrically weighted (P53 curve)	$V_{no(rms)}$	—	–70	—	dBmp
Receiving amplifier input IR (pin 13)						
Input impedance		Z_i	16	20	24	k Ω
Receiving amplifier outputs QR– QR+ (pins 4, 5)						
Output impedance	single-ended	Z_o	—	4	—	Ω
Voltage gain	Fig. 22; $I_{line} = 15$ mA; R4 = 100 k Ω					
single-ended; $R_T = 300$ Ω		G_V	32.8	33.8	34.8	dB
differential; $R_T = 600$ Ω		G_V	38.8	39.8	40.8	dB
Variation with frequency, referred to 0.8 kHz	$f = 300$ and 3400 Hz	ΔG_{Vf}	–0.5	± 0.25	0.5	dB
Variation with temperature, referred to 25 $^{\circ}$ C	without R6; $I_{line} = 50$ mA; $T_{amb} = -25$ and $+75$ $^{\circ}$ C	ΔG_{VT}	—	± 0.2	—	dB
Output voltage (RMS value)	THD = 2%; sinewave drive; R4 = 100 k Ω ; $I_{line} = 15$ mA					
single-ended; $R_T = 150$ Ω	$I_p = 0$ mA	$V_o(rms)$	0.21	0.26	—	V
	$I_p = 2$ mA	$V_o(rms)$	0.30	0.40	—	V
differential; $R_T = 450$ Ω	$I_p = 0$ mA	$V_o(rms)$	0.39	0.49	—	V
	$I_p = 2$ mA	$V_o(rms)$	0.62	0.72	—	V
differential; $C_T = 47$ nF; (100 Ω series resistor); $f = 3400$ Hz	$I_p = 0$ mA	$V_o(rms)$	0.59	0.69	—	V
	$I_p = 2$ mA	$V_o(rms)$	0.85	1.05	—	V

DEVELOPMENT DATA

parameter	conditions	symbol	min.	typ.	max.	unit
Output voltage (RMS value)	$I_p = 0 \text{ mA}$; THD = 10%; sinewave drive; $R_4 = 100 \text{ k}\Omega$; single-ended; $R_T = 150 \Omega$; $I_{line} = 5 \text{ mA}$ $I_{line} = 7 \text{ mA}$	$V_{o(rms)}$	—	20	—	mV
		$V_{o(rms)}$	—	100	—	mV
Noise output voltage (RMS value)	$I_{line} = 15 \text{ mA}$; $R_4 = 100 \text{ k}\Omega$; psophometrically weighted (P53 curve); pin 1R open single-ended; $R_T = 300 \Omega$ differential; $R_T = 600 \Omega$	$V_{no(rms)}$	—	70	—	μV
		$V_{no(rms)}$	—	140	—	μV
Noise output voltage (RMS value)	in circuit of Fig. 22; S1 in position 2; single-ended; $R_T = 300 \Omega$ $R_7 = 68 \text{ k}\Omega$ $R_7 = 24.9 \text{ k}\Omega$	$V_{no(rms)}$	—	120	—	μV
		$V_{no(rms)}$	—	80	—	μV
Gain adjustment input GAR (pin 6)						
Receiving amplifier, gain adjustment range		ΔG_v	-11	—	+8	dB
MUTE INPUT (pin 14)						
Input voltage HIGH		V_{IH}	$1.5 + V_{SLPE}$	—	$V_{CC1} + 0.4$	V
Input voltage LOW		V_{IL}	0	—	$0.3 + V_{SLPE}$	V
Input current		I_{mute}	—	11	20	μA
Change of microphone amplifier gain at mute-on	MUTE = HIGH	ΔG_v	—	100	—	dB
Voltage gain from input DTMF-SLPE to QR+ output with mute on	MUTE = HIGH; single-ended load; $R_L = 300 \Omega$	G_v	—	-18	—	dB

CHARACTERISTICS (continued)

parameter	conditions	symbol	min.	typ.	max.	unit
Power-down input PD (pin 15)						
Input voltage HIGH		V_{IH}	$1.5 + V_{SLPE}$	—	$V_{CC1} + 0.4$	V
Input voltage LOW		V_{IL}	0	—	$0.3 + V_{SLPE}$	V
Input current		I_{PD}	—	5	10	μA
Automatic gain control input AGC (pin 18)						
Controlling the gain from IR (pin 13) to QR+, QR— (pins 4, 5) and the gain from MIC+, MIC— (pins 8, 9) to LN (pin 1)	$R6 = 51 \text{ k}\Omega$ (between pins 18 and 11)					
Gain control range with respect to $I_{line} = 15 \text{ mA}$	$I_{line} = 73 \text{ mA}$	ΔG_V	—	-8.6	—	dB
Highest line current for maximum gain		I_{line}	—	20	—	mA
Lowest line current for minimum gain		I_{line}	—	70	—	mA

DEVELOPMENT DATA

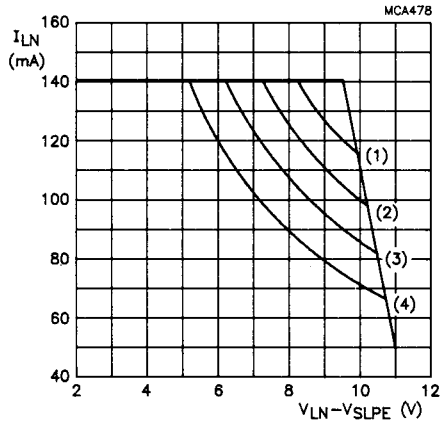

	T_{amb}	P_{tot}
(1)	45 °C	1143 mW
(2)	55 °C	1000 mW
(3)	65 °C	857 mW
(4)	75 °C	714 mW

Fig.19 TEA1063 safe operating area.

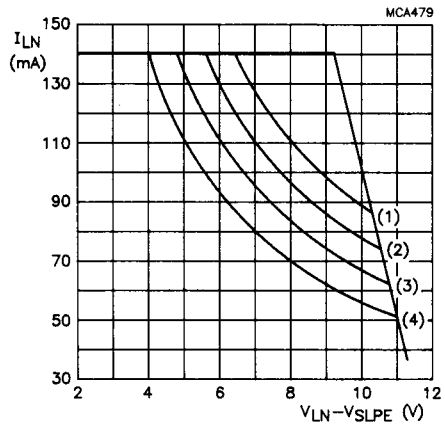

	T_{amb}	P_{tot}
(1)	45 °C	888 mW
(2)	55 °C	777 mW
(3)	65 °C	666 mW
(4)	75 °C	555 mW

Fig.20 TEA1063T safe operating area.

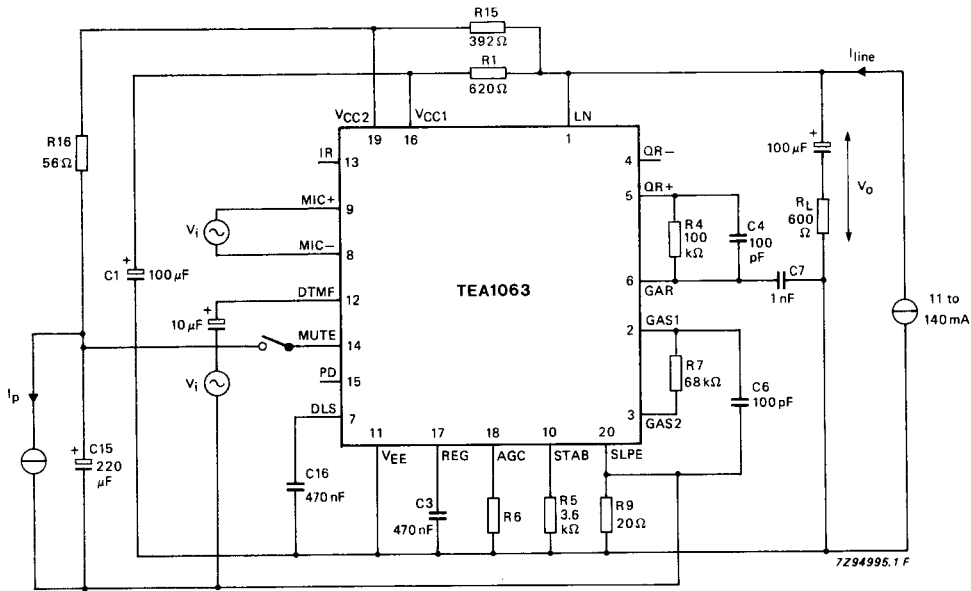

Fig. 21 Test circuit for defining voltage gain of MIC-, MIC+ and DTMF inputs; voltage gain (G_V) is defined as $20 \log|V_o/V_i|$. For measuring the gain from MIC+ and MIC- the MUTE input should be LOW or open-circuit; for measuring the DTMF input, the MUTE input should be HIGH. Inputs not being tested should be open-circuit.

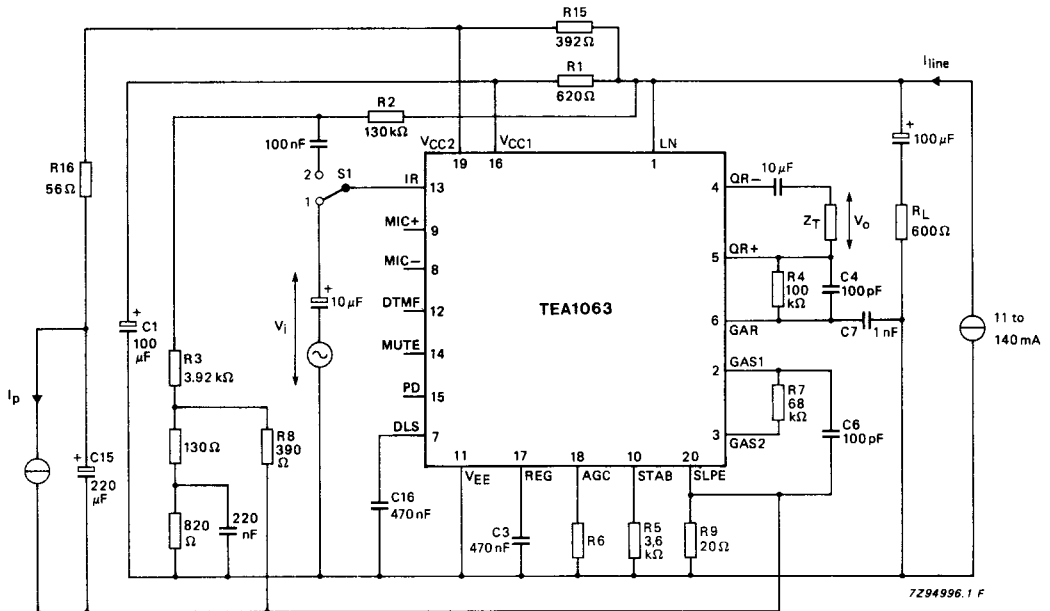

Fig. 22 Test circuit for defining voltage gain of the receiving amplifier, voltage gain (G_V) is defined as $20 \log|V_o/V_i|$ (with S1 in position 1).

APPLICATION INFORMATION

The basic application circuit is shown in Fig. 23 and some typical applications are shown in Figs 24, 25 and 26.

In the basic application, the circuit provides two possibilities for supplies to peripheral circuits:

- regulated line voltage V_{LN} (stabilized $V_{LN-SLPE}$) and unregulated supply voltage for peripheral circuits, the supply voltage is dependent only on the peripheral supply current. This application is comparable to that used for TEA1060/TEA1061, TEA1067 and TEA1068;
- stabilized supply voltage for peripherals ($V_{CC2-SLPE}$), the DC line voltage depends on the current flowing to the peripheral circuits.

DEVELOPMENT DATA

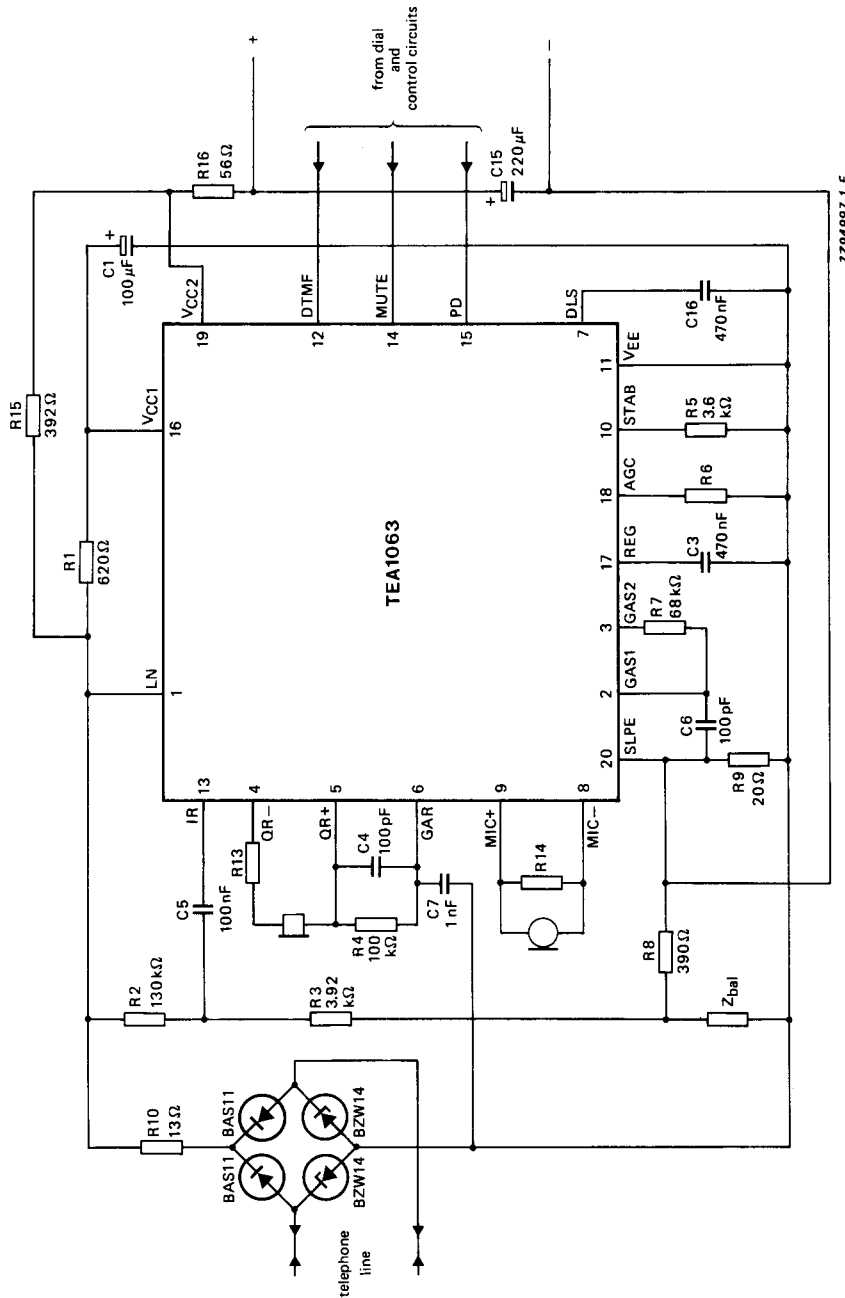

7Z94997.1 F

Fig. 23 Basis application of the TEA 1063 with stabilized supply for peripherals, shown here with a piezo-electric earpiece and DTMF dialling. The diode bridge and R10 limit the current into, and the voltage across, the circuit during line transients. A different protection arrangement is required for pulse dialling or register recall.

For the basic application giving regulated line voltage the above circuit is changed as follows:

- R 15 must be short-circuited;
- the value of R 16 is changed to 392 Ω;
- the value of C 3 is changed to 4.7 μF.

APPLICATION INFORMATION (continued)

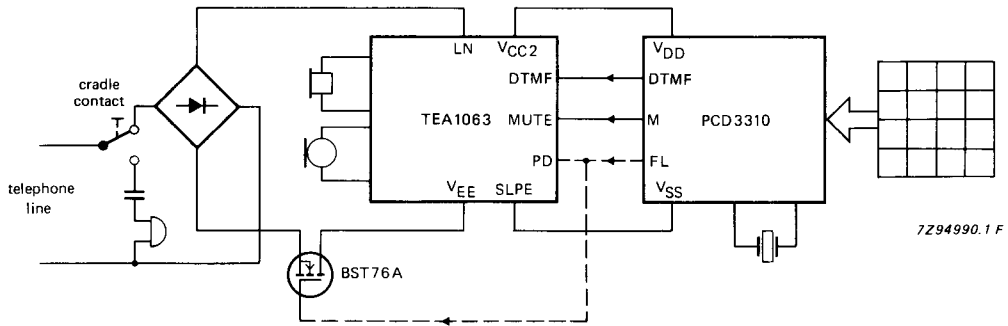

Fig. 24 Typical DTMF-pulse set application circuit (simplified) showing the TEA1063 with the CMOS bilingual dialling circuit PCD3310; the broken line indicates optional flash (register recall by timed loop break).

DEVELOPMENT DATA

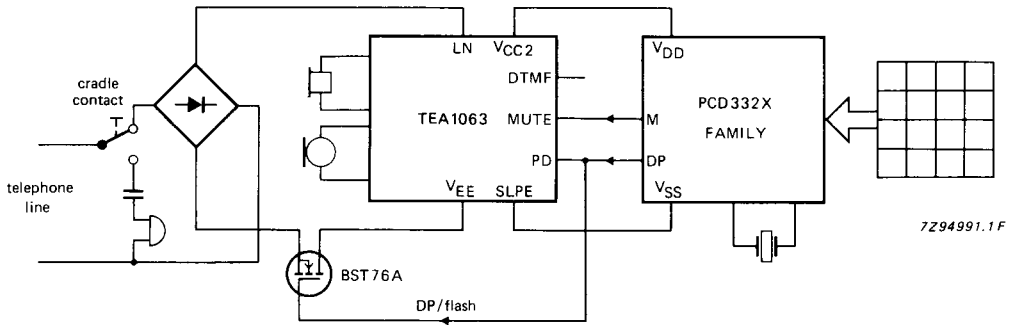

Fig. 25 Typical pulse dial set application circuit (simplified) showing the TEA1063 with one of the PCD332X family of CMOS interrupted current-loop dialling circuits.

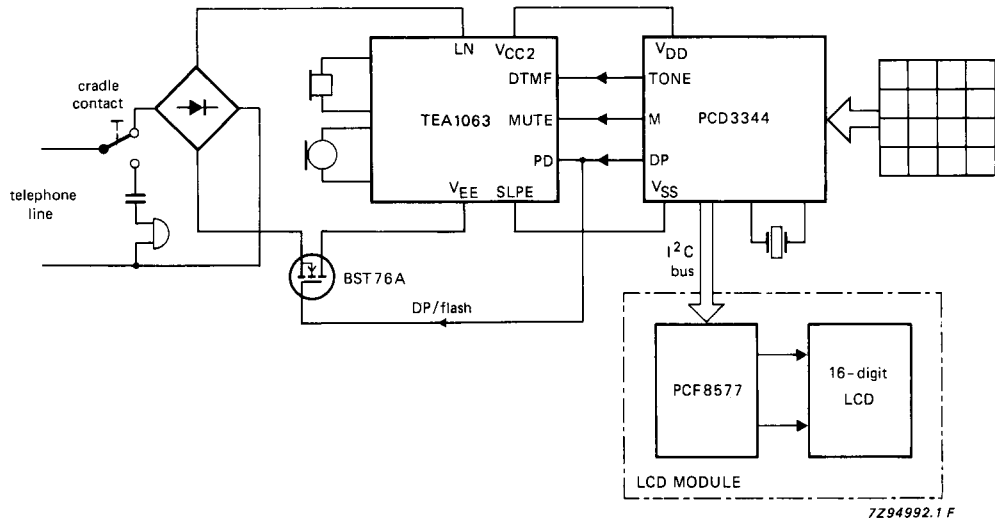

Fig. 26 Typical dual-standard (pulse and DTMF) feature phone application circuit (simplified) showing the TEA1063 and the PCD3344 CMOS telephone microcontroller with on-chip DTMF generator plus I²C-bus.