

Phase-out/Discontinued

GENERAL PURPOSE L-BAND DOWN CONVERTER ICs

DESCRIPTION

The μ PC2721/2722 are Silicon monolithic ICs designed for L-band down converter. These ICs consist of double balanced mixer, local oscillator, local oscillation buffer amplifier, IF amplifier, and voltage regulator.

The packages are 8 pin SOP or SSOP suitable for high-density surface mount.

FEATURES

- Wide band operation $f_{RF} = 0.9$ to 2.0 GHz
- Two products in IF output variation are prepared
 μ PC2721: Emitter follower output type = 50 Ω constant resistive impedance
 μ PC2722: Open collector output type = High impedance output dependent on external inductance.
- Single-end push-pull IF amplifier suppresses fluctuation in output impedance.
- Supply voltage: 5 V
- Low current consumption (μ PC2721: $I_{CC} = 38$ mA typ., μ PC2722: $I_{CC} = 28$ mA typ.)
- Packaged in 8 pin SOP or SSOP suitable for high-density mounting

ORDERING INFORMATION

PART NUMBER	PACKAGE	PACKAGE STYLE
μ PC2721GR-E1 μ PC2722GR-E1	8 pin Plastic SOP (225 mil)	Embossed tape 12 mm wide 2.5 k/REEL. Pin 1 indicates pull-out direction of tape.
μ PC2721GR-E2 μ PC2722GR-E2	8 pin Plastic SOP (225 mil)	Embossed tape 12 mm wide 2.5 k/REEL. Pin 1 indicates roll-in direction of tape.
μ PC2721GV-E1 μ PC2722GV-E1	8 pin Plastic SSOP (175 mil)	Embossed tape 8 mm wide 1 k/REEL. Pin 1 indicates pull-out direction of tape.

For evaluation sample order, please contact your local NEC office.

(Part number for sample order: μ PC2721GR, μ PC2722GR, μ PC2721GV, μ PC2722GV)

Caution electro-static sensitive device

The information in this document is subject to change without notice. Before using this document, please confirm that this is the latest version.
 Not all devices/types available in every country. Please check with local NEC representative for availability and additional information.

INTERNAL BLOCK DIAGRAM

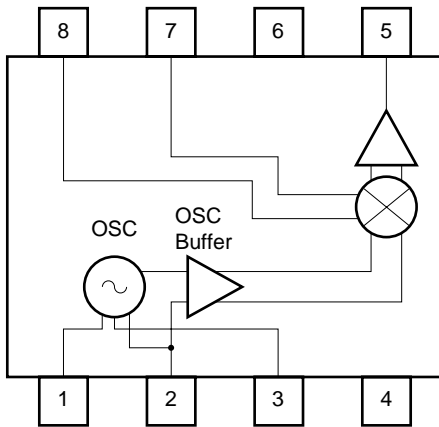

PIN CONFIGURATION (Top View)

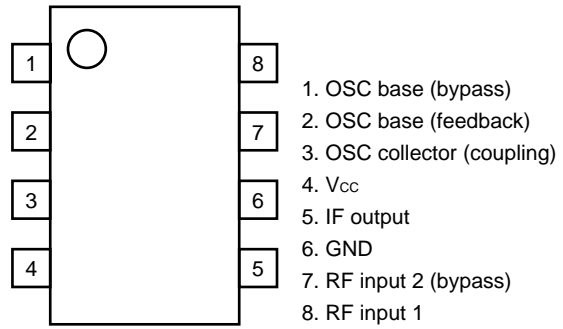

PIN No.	SYMBOL	PIN VOLT TYP.(V)	Function and Explanation	Equivalent circuit
1	OSC base (bypass)	2.9	Internal oscillator consists in balance amplifier. 2 pin and 3 pin should be externally equipped with tank resonator circuit in order to oscillate with feedback loop. 1 pin should be grounded through coupling capacitor to 0.5 pF. 3 pin is defined as open collector. This pin should be coupled through resistor or chock coil in order to adjust Q and be supplied voltage. In case of abnormal oscillation, adjust its Q lower to stabilize the operation.	
2	OSC base (feedback)	2.9		
3	OSC collector (coupling)	5.0		
4	Vcc	5.0	Supply voltage pin for the IC.	
5	IF output	μ PC2721 2.9	In μ PC2721, IF amplifier is designed as single-end push-pull amplifier. This pin is assigned for the emitter follower output with 50 Ω constant resistive impedance in wide band.	μ PC2721
		μ PC2722 5.0	In μ PC2722, IF amplifier is designed as balance amplifier. This pin is assigned for the open collector output with high impedance dependent on external inductance.	μ PC2722
6	GND	0.0	GND pin for the IC.	
7	RF input 2 (bypass)	2.4	7 pin and 8 pin are inputs for mixer designed as double balanced type. Either pin can be assigned for input and another for ground.	
8	RF input 1	2.4		

ABSOLUTE MAXIMUM RATINGS

PARAMETER	SYMBOL	RATING	UNIT	TEST CONDITION
Supply Voltage	V _{CC}	6.0	V	T _A = 25 °C
Power Dissipation	P _D	250	mW	T _A = 85 °C ^{Note 1}
Operating temperature range	T _A	-40 to +85	°C	
Storage temperature range	T _{stg}	-65 to +150	°C	

Note 1: Mounted on 50 × 50 × 1.6 mm double copper clad epoxy glass board.

RECOMMENDED OPERATING RANGE

PARAMETER	SYMBOL	MIN.	TYP.	MAX.	UNIT
Supply Voltage	V _{CC}	4.5	5.0	5.5	V
Operating temperature range	T _A	-40	+25	+85	°C

ELECTRICAL CHARACTERISTICS (V_{CC} = 5.0 V, T_A = +25 °C^{Note 2})

PARAMETER	SYMBOL	μ PC2721			μ PC2722			UNIT	TEST CONDITIONS
		MIN.	TYP.	MAX.	MIN.	TYP.	MAX.		
Circuit Current	I _{CC}	29	38	45.5	19	28	37	mA	no input signal
Lower Input Frequency	f _{RF1}			0.9			0.9	GHz	f _{IF} = 50 to 600 MHz (C2721)
Upper Input Frequency	f _{RF2}	2.0			2.0			GHz	f _{IF} = DC to 600 MHz (C2722)
Conversion Gain 1	CG1	18	21	24	15	18	21	dB	f _{RF} = 900 MHz, f _{IF} = 402.8 MHz
Conversion Gain 2	CG2	18	21	24	15	18	21	dB	f _{RF} = 2.0 GHz, f _{IF} = 402.8 MHz
Noise Figure 1	NF1	-	9	13	-	9	13	dB	f _{RF} = 900 MHz, f _{IF} = 402.8 MHz
Noise Figure 2	NF2	-	11	15	-	9	13	dB	f _{RF} = 2.0 GHz, f _{IF} = 402.8 MHz
Maximum output power 1	P _{O(SAT)1}	+2	+7	-	+2	+6	-	dBm	f _{RF} = 900 MHz, f _{IF} = 402.8 MHz
Maximum output power 2	P _{O(SAT)2}	+2	+7	-	+2	+6	-	dBm	f _{RF} = 2.0 GHz, f _{IF} = 402.8 MHz

Note 2: on test circuit

STANDARD CHARACTERISTICS (FOR REFERENCE) (V_{CC} = 5 V, T_A = 25 °C^{Note 2})

PARAMETER	SYMBOL	REFERENCE VALUES		UNIT	TEST CONDITIONS
		μ PC2721	μ PV2722		
Conversion Gain 3	CG3	22	19	dB	f _{RF} = 900 MHz, f _{IF} = 50 MHz
Conversion Gain 4	CG4	22	19	dB	f _{RF} = 2.0 MHz, f _{IF} = 50 MHz
Conversion Gain 5	CG5	21	18	dB	f _{RF} = 900 MHz, f _{IF} = 479.5 MHz
Conversion Gain 6	CG6	21	18	dB	f _{RF} = 2.0 MHz, f _{IF} = 479.5 MHz
Conversion Gain 7	CG7	19.5	17	dB	f _{RF} = 900 MHz, f _{IF} = 600 MHz
Conversion Gain 8	CG8	19.5	17	dB	f _{RF} = 2.0 MHz, f _{IF} = 600 MHz
Third Intermodulation Distortion 1	IM ₃ 1	38.0	42.0	dBc	f _{RF} = 900, 938 MHz, P _{in} = -30 dBm
Third Intermodulation Distortion 2	IM ₃ 2	38.0	42.0	dBc	f _{RF} = 2.0, 2.038 GHz, P _{in} = -30 dBm

TYPICAL CHARACTERISTICS ($T_A = +25\text{ }^\circ\text{C}$)

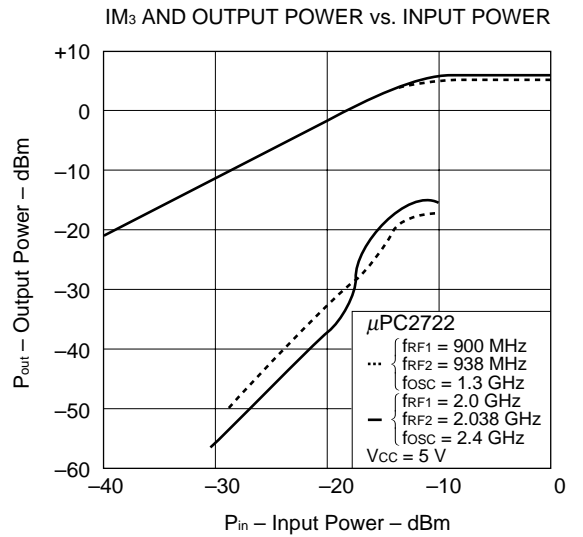
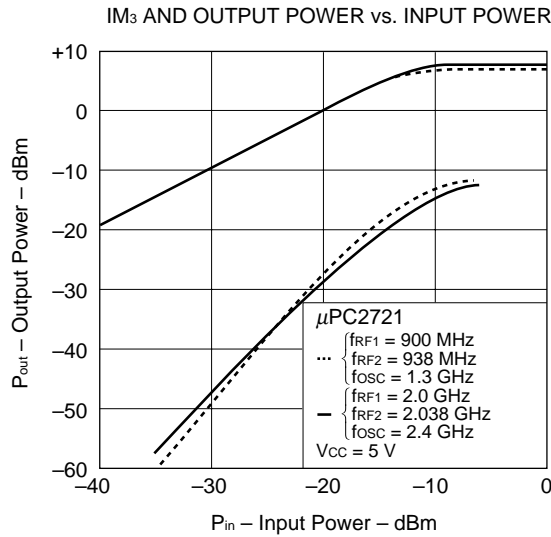
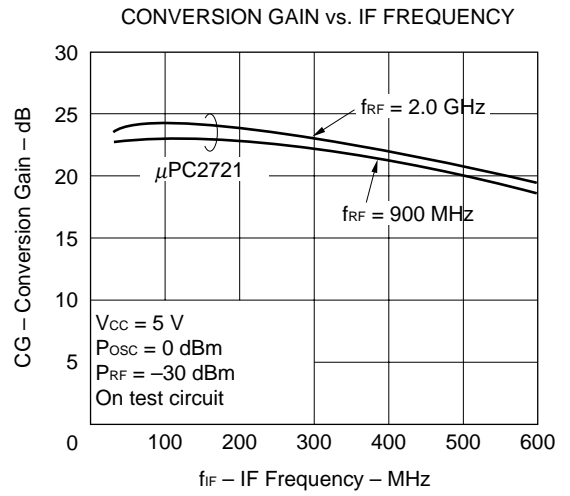
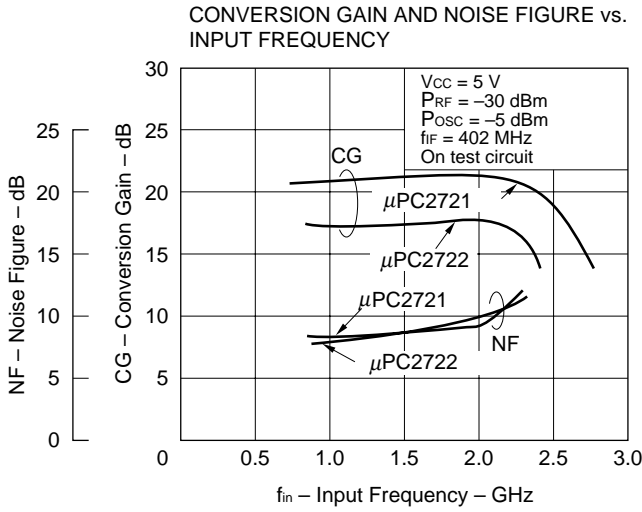
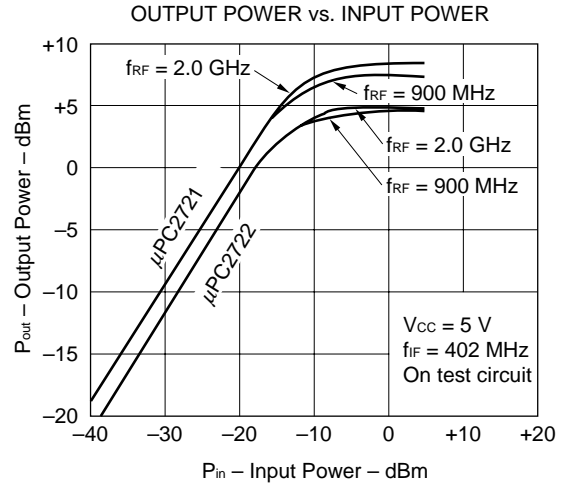
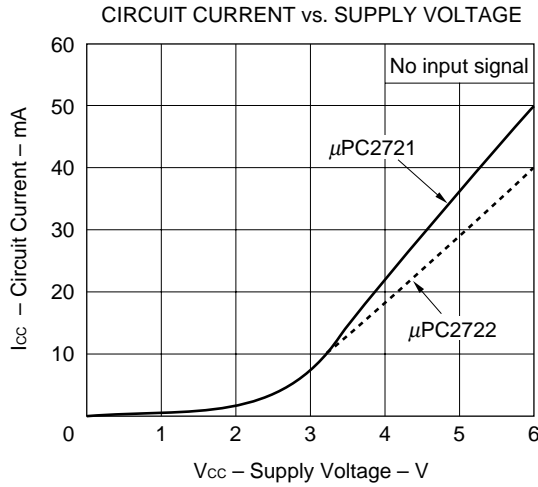

OSC-TUNING VOLTAGE vs. OSC FREQUENCY

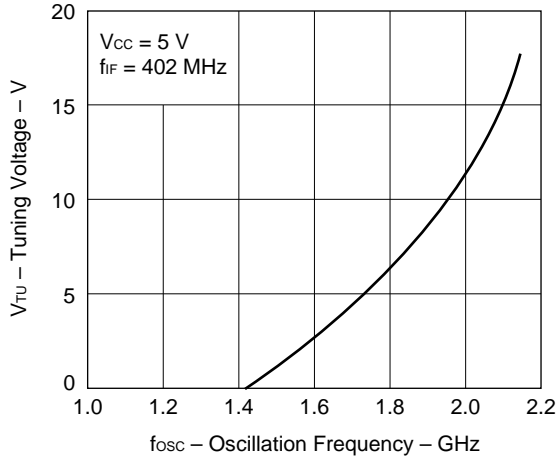

LOWER V_{CC} VOLTAGE IN OSC OPERATION vs. OSC FREQUENCY

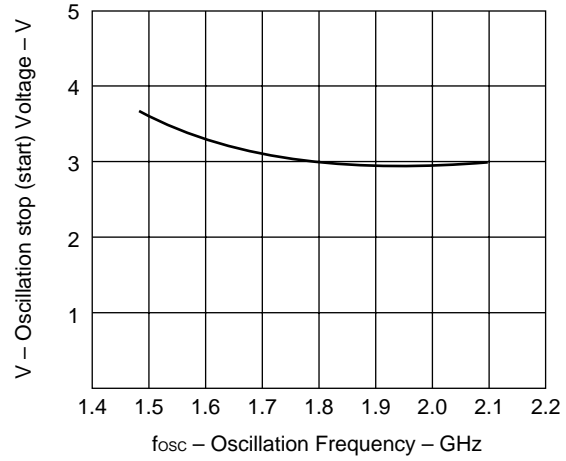

μ PC2721 OSC FREQUENCY STABILITY vs. OSC FREQUENCY

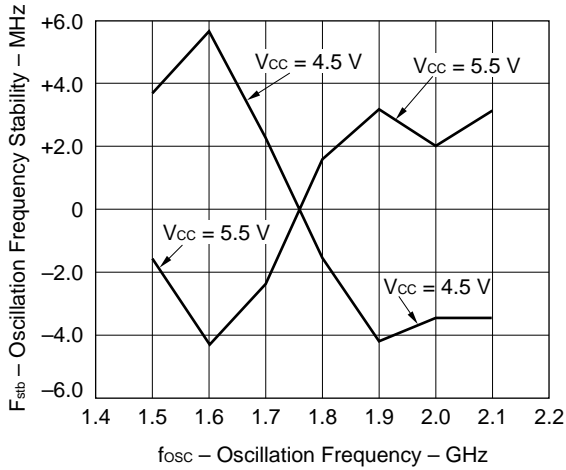

μ PC2722 OSC FREQUENCY STABILITY vs. OSC FREQUENCY

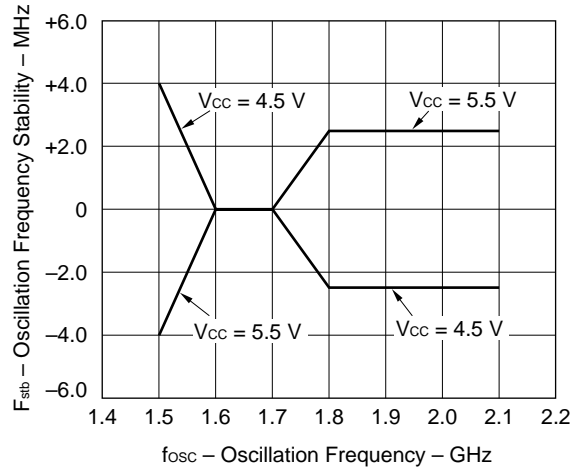

TEST CIRCUIT

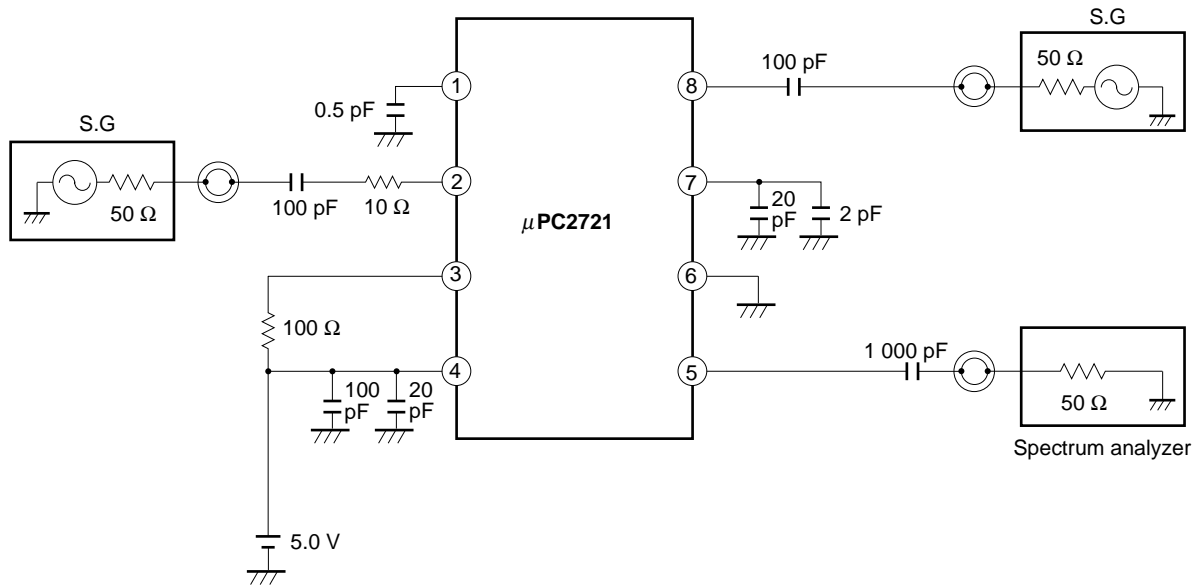

APPLICATION CIRCUIT FOR REFERENCE

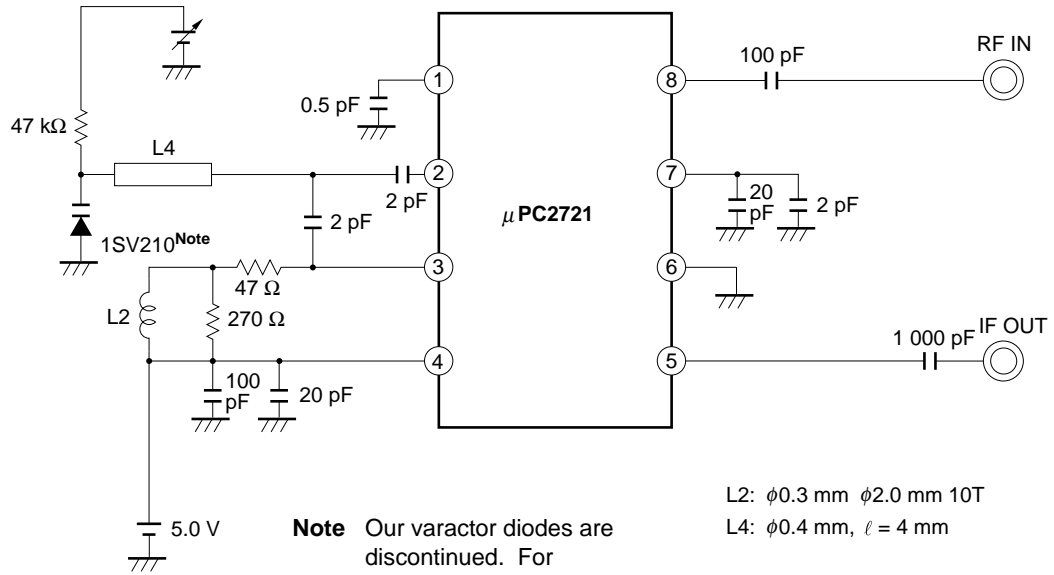

Note Our varactor diodes are discontinued. For varactor diode, contact other supplier.

L2: ϕ 0.3 mm ϕ 2.0 mm 10T
L4: ϕ 0.4 mm, $l = 4$ mm

The application circuits and their parameters are for reference only and are not intended for use in actual design-ins.

TEST CIRCUIT

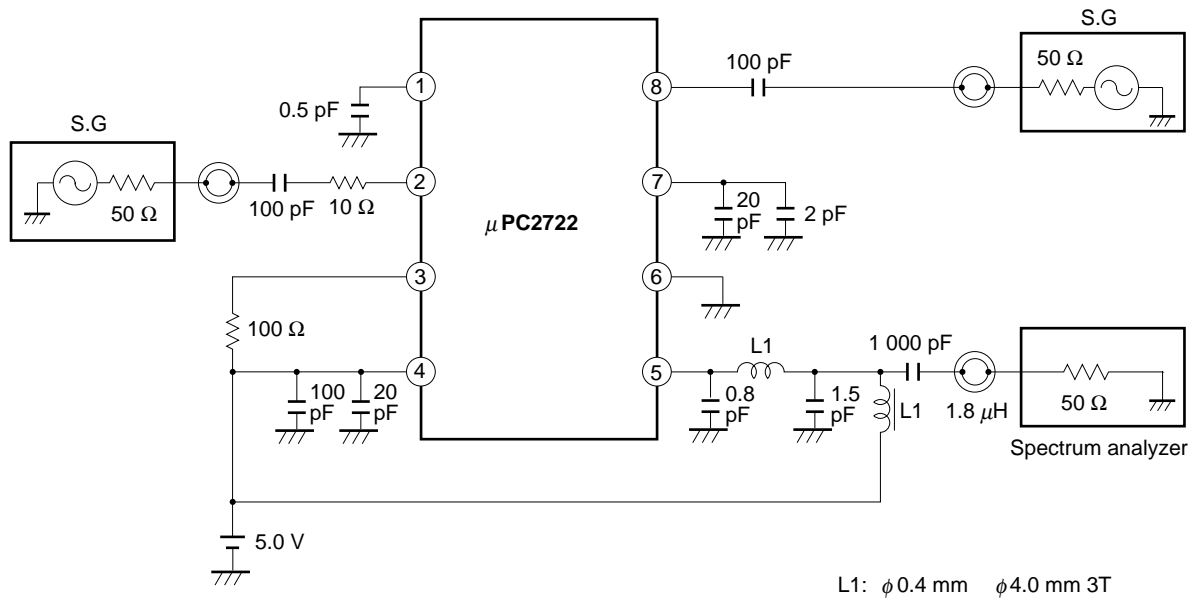

L1: ϕ 0.4 mm ϕ 4.0 mm 3T

APPLICATION CIRCUIT FOR REFERENCE

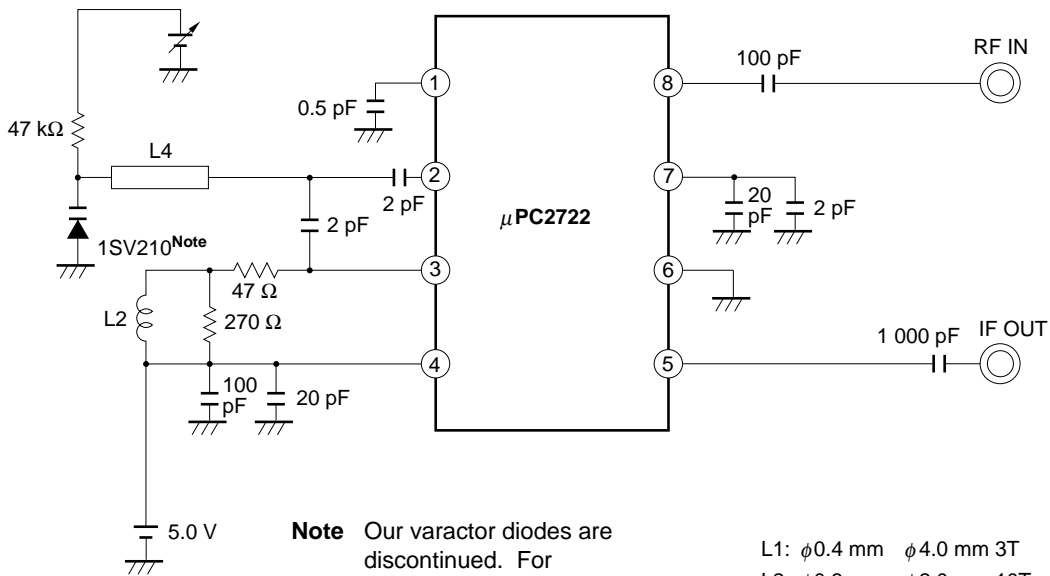

Note Our varactor diodes are discontinued. For varactor diode, contact other supplier.

L1: ϕ 0.4 mm ϕ 4.0 mm 3T
 L2: ϕ 0.3 mm ϕ 2.0 mm 10T
 L4: ϕ 0.4 mm, ℓ = 4 mm

The application circuits and their parameters are for reference only and are not intended for use in actual design-ins.

PACKAGE DIMENSIONS

★ 8 PIN PLASTIC SOP (225 mil) (UNIT: mm)

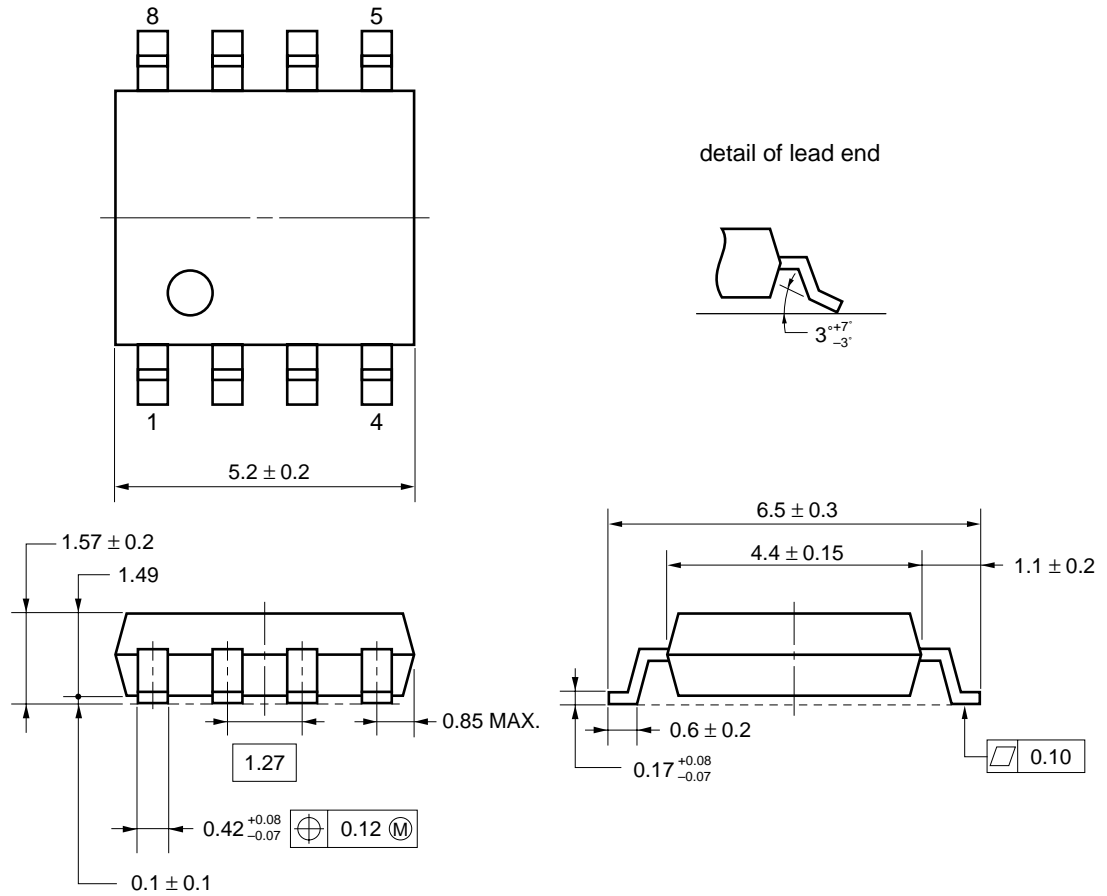

NOTE Each lead centerline is located within 0.12 mm of its true position (T.P.) at maximum material condition.

8 PIN PLASTIC SSOP (175 mil) (UNIT: mm)

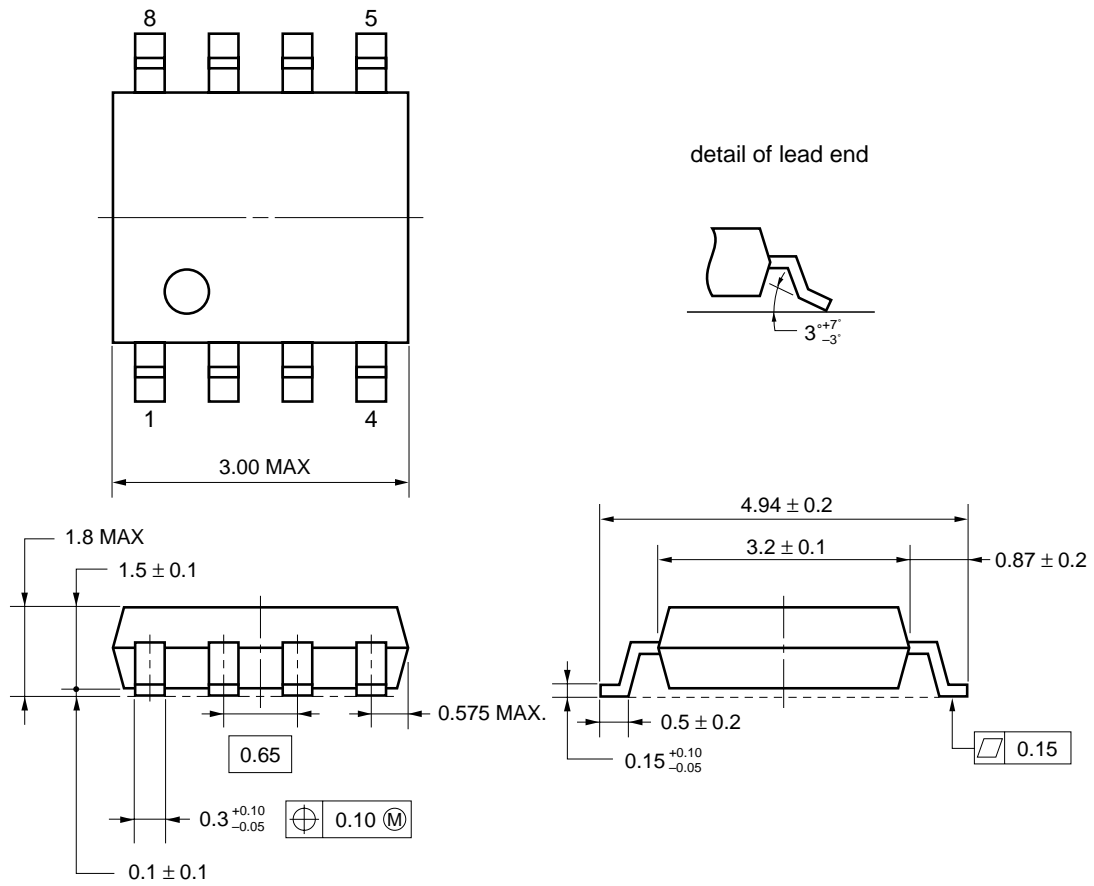

NOTE Each lead centerline is located within 0.10 mm of its true position (T.P.) at maximum material condition.

RECOMMENDED SOLDERING CONDITIONS

The following conditions (see table below) must be met when soldering this product.

Please consult with our sales officers in case other soldering process is used or in case soldering is done under different conditions.

For details of recommended soldering conditions for surface mounting, refer to information document SEMICONDUCTOR DEVICE MOUNTING TECHNOLOGY MANUAL (C10535E).

μPC2721/22

Soldering process	Soldering conditions	Symbol
Infrared ray reflow	Peak package's surface temperature: 235 °C or below, Reflow time: 30 seconds or below (210 °C or higher), Number of reflow process: 3, Exposure limit ^{Note} : None	IR35-00-3
VPS	Peak package's surface temperature: 215 °C or below, Reflow time: 40 seconds or below (200 °C or higher), Number of reflow process: 3, Exposure limit ^{Note} : None	VP15-00-3
Wave soldering	Solder temperature: 260 °C or below, Flow time: 10 seconds or below, Number of flow process: 1, Exposure limit ^{Note} : None	WS60-00-1
Partial heating method	Terminal temperature: 300 °C or below, Flow time: 3 seconds or below, Exposure limit ^{Note} : None	

Note Exposure limit before soldering after dry-pack package is opened.
Storage conditions: 25 °C and relative humidity at 65 % or less.

Caution Do not apply more than single process at once, except the "Partial heating method".

NESAT (NEC Silicon Advanced Technology) is a trademark of NEC Corporation.

- **The information in this document is subject to change without notice. Before using this document, please confirm that this is the latest version.**
 - No part of this document may be copied or reproduced in any form or by any means without the prior written consent of NEC Corporation. NEC Corporation assumes no responsibility for any errors which may appear in this document.
 - NEC Corporation does not assume any liability for infringement of patents, copyrights or other intellectual property rights of third parties by or arising from use of a device described herein or any other liability arising from use of such device. No license, either express, implied or otherwise, is granted under any patents, copyrights or other intellectual property rights of NEC Corporation or others.
 - Descriptions of circuits, software, and other related information in this document are provided for illustrative purposes in semiconductor product operation and application examples. The incorporation of these circuits, software, and information in the design of the customer's equipment shall be done under the full responsibility of the customer. NEC Corporation assumes no responsibility for any losses incurred by the customer or third parties arising from the use of these circuits, software, and information.
 - While NEC Corporation has been making continuous effort to enhance the reliability of its semiconductor devices, the possibility of defects cannot be eliminated entirely. To minimize risks of damage or injury to persons or property arising from a defect in an NEC semiconductor device, customers must incorporate sufficient safety measures in its design, such as redundancy, fire-containment, and anti-failure features.
 - NEC devices are classified into the following three quality grades:
"Standard", "Special", and "Specific". The Specific quality grade applies only to devices developed based on a customer designated "quality assurance program" for a specific application. The recommended applications of a device depend on its quality grade, as indicated below. Customers must check the quality grade of each device before using it in a particular application.
 - Standard: Computers, office equipment, communications equipment, test and measurement equipment, audio and visual equipment, home electronic appliances, machine tools, personal electronic equipment and industrial robots
 - Special: Transportation equipment (automobiles, trains, ships, etc.), traffic control systems, anti-disaster systems, anti-crime systems, safety equipment and medical equipment (not specifically designed for life support)
 - Specific: Aircraft, aerospace equipment, submersible repeaters, nuclear reactor control systems, life support systems or medical equipment for life support, etc.
- The quality grade of NEC devices is "Standard" unless otherwise specified in NEC's Data Sheets or Data Books. If customers intend to use NEC devices for applications other than those specified for Standard quality grade, they should contact an NEC sales representative in advance.