

W83627HG-AW
W83627G-AW
NUVOTON LPC I/O

Date : 2009/04/03 Revision : 2.63

Table of Contents

1.	GENERAL DESCRIPTION	1
2.	FEATURES	3
3.	BLOCK DIAGRAM FOR W83627G-AW	6
4.	BLOCK DIAGRAM FOR W83627HG-AW	7
5.	PIN CONFIGURATION FOR W83627G-AW	8
6.	PIN CONFIGURATION FOR W83627HG-AW	9
7.	PIN DESCRIPTION	10
7.1	LPC INTERFACE	11
7.2	FDC INTERFACE	12
7.3	MULTI-MODE PARALLEL PORT	13
7.4	SERIAL PORT INTERFACE	19
7.5	KBC INTERFACE	20
7.6	ACPI INTERFACE	20
7.7	HARDWARE MONITOR INTERFACE	21
7.8	GAME PORT & MIDI PORT	22
7.9	GENERAL PURPOSE I/O PORT	23
7.9.1	General Purpose I/O Port 1 (Power source is Vcc)	23
7.9.2	General Purpose I/O Port 2 (Power source is Vcc)	23
7.9.3	General Purpose I/O Port 3 (Power source is VSB)	24
7.10	POWER PINS	24
8.	HARDWARE MONITOR	25
8.1	GENERAL DESCRIPTION	25
8.2	ACCESS INTERFACE	25
8.2.1	LPC interface	25
8.3	ANALOG INPUTS	30
8.3.1	Monitor over 4.096V voltage :	30
8.3.2	Monitor negative voltage :	31
8.3.3	Temperature Measurement Machine	31
8.4	2.4 FAN SPEED COUNT AND FAN SPEED CONTROL	33
8.4.1	Fan speed count	33
8.4.2	Fan speed control	35
8.5	SMI# INTERRUPT MODE	35
8.5.1	Voltage SMI# mode :	35
8.5.2	Fan SMI# mode :	36
8.5.3	Temperature 1 SMI# modes	36
8.5.4	Temperature 2, 3 SMI# modes :	37
8.6	OVT# INTERRUPT MODE	39
8.7	REGISTERS AND RAM	40

9.	SERIAL IRQ	74
9.1	START FRAME	74
9.2	IRQ/DATA FRAME	74
9.3	STOP FRAME	75
10.	UART PORT	76
10.1	UNIVERSAL ASYNCHRONOUS RECEIVER/TRANSMITTER (UART A, UART B)	76
10.2	REGISTER DESCRIPTION	76
10.2.1	UART Control Register (UCR) (Read/Write).....	76
10.2.2	UART Status Register (USR) (Read/Write).....	79
10.2.3	Handshake Control Register (HCR) (Read/Write).....	79
10.2.4	Handshake Status Register (HSR) (Read/Write)	80
10.2.5	UART FIFO Control Register (UFR) (Write only).....	81
10.2.6	Interrupt Status Register (ISR) (Read only).....	82
10.2.7	Interrupt Control Register (ICR) (Read/Write).....	83
10.2.8	Programmable Baud Generator (BLL/BHL) (Read/Write).....	83
10.2.9	User-defined Register (UDR) (Read/Write).....	84
11.	CONFIGURATION REGISTER	85
11.1	PLUG AND PLAY CONFIGURATION	85
11.1.1	Compatible PnP.....	85
11.1.2	Configuration Sequence.....	86
11.2	CHIP (GLOBAL) CONTROL REGISTER.....	88
11.3	LOGICAL DEVICE 0 (FDC)	93
11.4	LOGICAL DEVICE 1 (PARALLEL PORT)	97
11.5	LOGICAL DEVICE 2 (UART A)	98
11.6	LOGICAL DEVICE 3 (UART B)	99
11.7	LOGICAL DEVICE 5 (KBC)	101
11.8	LOGICAL DEVICE 6 (CIR)	102
11.9	LOGICAL DEVICE 7 (GAME PORT, MIDI PORT AND GPIO PORT 1)	102
11.10	LOGICAL DEVICE 8 (GPIO PORT 2 AND WATCH DOG TIMER)	103
11.11	LOGICAL DEVICE 9 (GPIO PORT 3, VSB POWERED)	105
11.12	LOGICAL DEVICE A (ACPI)	106
11.13	LOGICAL DEVICE B (HARDWARE MONITOR)	113
12.	SPECIFICATIONS	115
12.1	ABSOLUTE MAXIMUM RATINGS.....	115
12.2	DC CHARACTERISTICS	115
13.	APPLICATION CIRCUITS	124
13.1	PARALLEL PORT EXTENSION FDD	124
13.2	PARALLEL PORT EXTENSION 2FDD	125
13.3	FOUR FDD MODE	125
14.	ORDERING INFORMATION	126
15.	TOP MARKING SPECIFICATIONS	126
16.	PACKAGE DIMENSIONS	127



17. REVISION HISTORY128

APPENDIX A : DEMO CIRCUIT131

1.

1. GENERAL DESCRIPTION

The W83627HG and W83627G are evolving product from Winbond's most popular I/O family. They feature a whole new interface, namely LPC (Low Pin Count) interface, which will be supported in the next generation Intel chip-set. This interface as its name suggests is to provide an economical implementation of I/O's interface with lower pin count and still maintains equivalent performance as its ISA interface counterpart. Approximately 40 pin counts are saved in LPC I/O comparing to ISA implementation. With this additional freedom, we can implement more devices on a single chip as demonstrated in W83627G/HG's integration of Game Port and MIDI Port. It is fully transparent in terms of software which means no BIOS or device driver update is needed except chip-specific configuration.

The disk drive adapter functions of W83627G/HG include a floppy disk drive controller compatible with the industry standard 82077/ 765, data separator, write pre-compensation circuit, decode logic, data rate selection, clock generator, drive interface control logic, and interrupt and DMA logic. The wide range of functions integrated onto the W83627G/HG greatly reduces the number of components required for interfacing with floppy disk drives. The W83627G/HG supports four 360K, 720K, 1.2M, 1.44M, or 2.88M disk drives and data transfer rates of 250 Kb/s, 300 Kb/s, 500 Kb/s, 1 Mb/s, and 2 Mb/s.

The W83627G/HG provides two high-speed serial communication ports (UARTs), one of which supports serial Infrared communication. Each UART includes a 16-byte send/receive FIFO, a programmable baud rate generator, complete modem control capability, and a processor interrupt system. Both UARTs provide legacy speed with baud rate up to 115.2k bps and also advanced speed with baud rates of 230k, 460k, or 921k bps which support higher speed modems. In addition, the W83627G/HG provides IR functions: IrDA 1.0 (SIR for 1.152K bps) and TV remote IR (Consumer IR, supporting NEC, RC-5, extended RC-5, and RECS-80 protocols).

The W83627G/HG supports one PC-compatible printer port (SPP), Bi-directional Printer port (BPP) and also Enhanced Parallel Port (EPP) and Extended Capabilities Port (ECP). Through the printer port interface pins, also available are: Extension FDD Mode and Extension 2FDD Mode allowing one or two external floppy disk drives to be connected.

The configuration registers support mode selection, function enable/disable, and power down function selection. Furthermore, the configurable PnP features are compatible with the plug-and-play feature demand of Windows 95/98TM, which makes system resource allocation more efficient than ever.

The W83627G/HG provides functions that complies with ACPI (*Advanced Configuration and Power Interface*), which includes support of legacy and ACPI power management through PME# or PSOUT# function pins. For OnNow keyboard Wake-Up, OnNow mouse Wake-Up, and OnNow CIR Wake-Up. The W83627G/HG also has auto power management to reduce the power consumption.

The keyboard controller is based on 8042 compatible instruction set with a 2K Byte programmable ROM and a 256-Byte RAM bank. Keyboard BIOS firmware are available with optional AMIKEYTM-2, Phoenix MultiKey/42TM, or customer code.

The W83627G/HG provides a set of flexible I/O control functions to the system designer through a set of General Purpose I/O ports. These GPIO ports may serve as simple I/O or may be individually configured to provide a predefined alternate function. General Purpose Port 1 is designed to be functional even in power down mode (VCC is off).

The W83627G/HG is made to fully comply with Microsoft PC98 and PC99 Hardware Design Guide. Moreover W83627G/HG is made to meet the specification of PC98/PC99's requirement in the power management : ACPI and DPM (Device Power Management) .

The W83627G/HG contains a game port and a MIDI port. The game port is designed to support 2 joysticks and can be applied to all standard PC game control devices, They are very important for a entertainment or consumer computer.

Only the W83627HG support hardware status monitoring for personal computers. It can be used to monitor several critical hardware parameters of the system, including power supply voltages, fan speeds, and temperatures, which are very important for a high-end computer system to work stably and properly.

2. FEATURES

General

- Meet LPC Spec. 1.0
- Support LDRQ# (LPC DMA) , SERIRQ (serial IRQ)
- Include all the features of Winbond I/O W83977TF and W83977EF
- Integrate Hardware Monitor functions
- Compliant with Microsoft PC98/PC99 Hardware Design Guide
- Support DPM (Device Power Management) , ACPI
- Programmable configuration settings
- Single 24 or 48 MHz clock input

FDC

- Compatible with IBM PC AT disk drive systems
- Variable write pre-compensation with track selectable capability
- Support vertical recording format
- DMA enable logic
- 16-byte data FIFOs
- Support floppy disk drives and tape drives
- Detects all overrun and underrun conditions
- Built-in address mark detection circuit to simplify the read electronics
- FDD anti-virus functions with software write protect and FDD write enable signal (write data signal was forced to be inactive)
- Support up to four 3.5-inch or 5.25-inch floppy disk drives
- Completely compatible with industry standard 82077
- 360K/720K/1.2M/1.44M/2.88M format; 250K, 300K, 500K, 1M, 2M bps data transfer rate
- Support 3-mode FDD, and its Win95/98 driver

UART

- Two high-speed 16550 compatible UARTs with 16-byte send/receive FIFOs
- MIDI compatible
- Fully programmable serial-interface characteristics :
 - 5, 6, 7 or 8-bit characters
 - Even, odd or no parity bit generation/detection
 - 1, 1.5 or 2 stop bits generation
- Internal diagnostic capabilities :
 - Loop-back controls for communications link fault isolation
 - Break, parity, overrun, framing error simulation



- Programmable baud generator allows division of 1.8461 MHz and 24 MHz by 1 to $(2^{16}-1)$
- Maximum baud rate up to 921k bps for 14.769 MHz and 1.5M bps for 24 MHz

Infrared

- Support IrDA version 1.0 SIR protocol with maximum baud rate up to 115.2K bps

Parallel Port

- Compatible with IBM parallel port
- Support PS/2 compatible bi-directional parallel port
- Support Enhanced Parallel Port (EPP) – Compatible with IEEE 1284 specification
- Support Extended Capabilities Port (ECP) – Compatible with IEEE 1284 specification
- Extension FDD mode supports disk drive B; and Extension 2FDD mode supports disk drives A and B through parallel port
- Enhanced printer port back-drive current protection

Keyboard Controller

- 8042 based with optional F/W from AMIKKEY™-2, or customer code with 2K bytes of programmable ROM, and 256 bytes of RAM
- Asynchronous Access to Two Data Registers and One status Register
- Software compatibility with the 8042
- Support PS/2 mouse
- Support port 92
- Support both interrupt and polling modes
- Fast Gate A20 and Hardware Keyboard Reset
- 8 Bit Timer/ Counter
- Support binary and BCD arithmetic
- 6 MHz, 8 MHz, 12 MHz, or 16 MHz operating frequency

Game Port

- Support two separate Joysticks
- Support every Joystick two axis (X,Y) and two button (A,B) controllers

MIDI Port

- The baud rate is 31.25 Kbaud
- 16-byte input FIFO
- 16-byte output FIFO

General Purpose I/O Ports

- 22 programmable general purpose I/O ports



- General purpose I/O ports can serve as simple I/O ports, interrupt steering inputs, watch dog timer output, power LED output, infrared I/O pins, KBC control I/O pins, suspend LED output, RSMRST# signal, PWROK signal, Beep output
- Functional in power down mode (GP1 only)

OnNow Functions

- Keyboard Wake-Up by programmable keys
- Mouse Wake-Up by programmable buttons
- CIR Wake-Up by programmable keys
- On Now Wake-Up from all of the ACPI sleeping states (S1-S5)

Hardware Monitor Functions (Only for W83627HG)

- 5 VID input pins for CPU Vcore identification
- 3 thermal inputs from optionally remote thermistors or 2N3904 transistors or Pentium™ II (Deschutes) thermal diode output
- 7 positive voltage inputs (typical for +12V, -12V, +5V, -5V, +3.3V, VcoreA, VcoreB)
- 2 intrinsic voltage monitoring (typical for Vbat, +5VSB)
- 3 fan speed monitoring inputs
- 2 fan speed control
- Build in Case open detection circuit
- WATCHDOG comparison of all monitored values
- Programmable hysteresis and setting points for all monitored items
- Over temperature indicate output
- Automatic Power On voltage detection Beep
- Issue SMI#, IRQ, OVT# to activate system protection
- Intel LDCM™ / Acer ADM™ compatible

Package

- 128-pin PQFP

3. Block Diagram for W83627G-AW

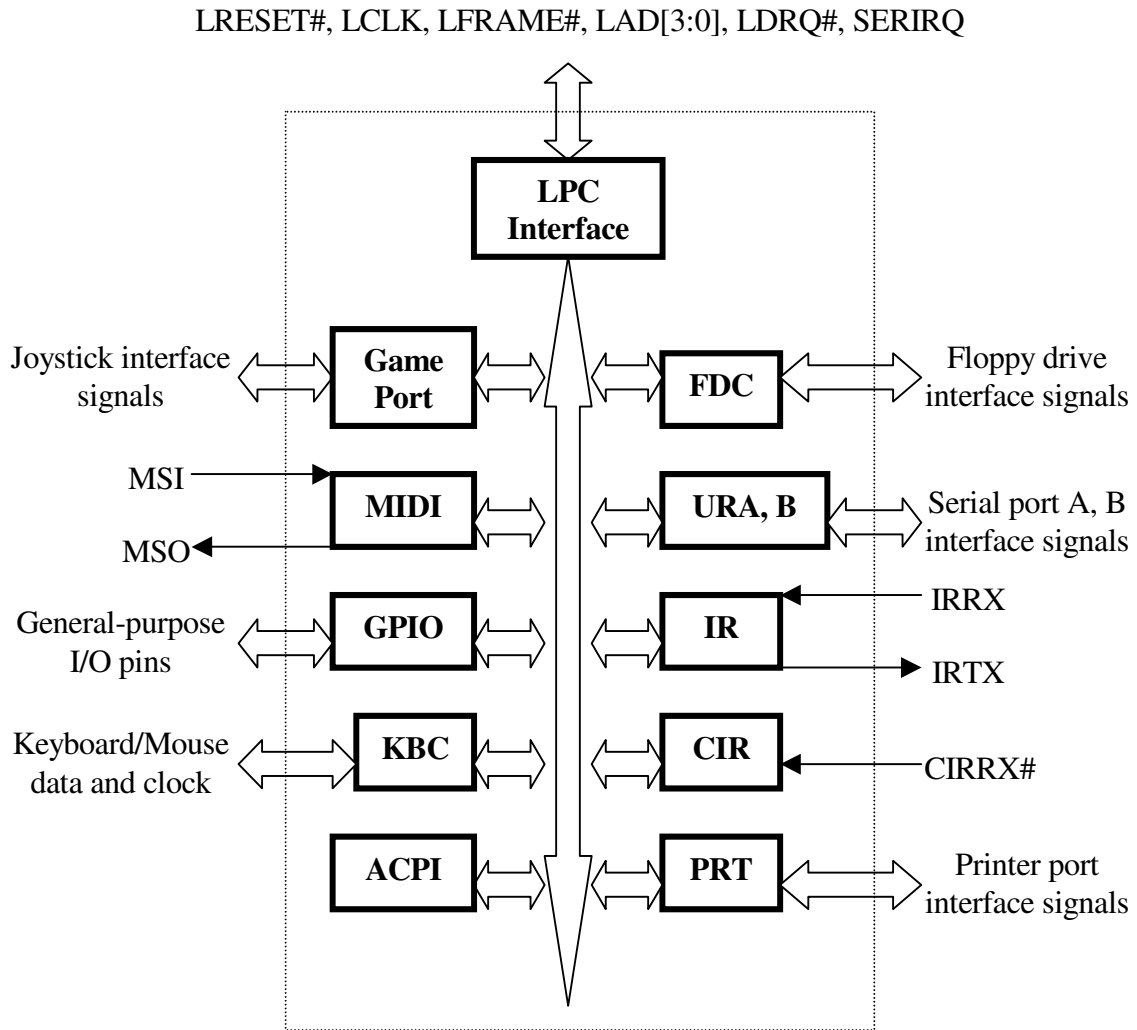

4. BLOCK DIAGRAM FOR W83627HG-AW

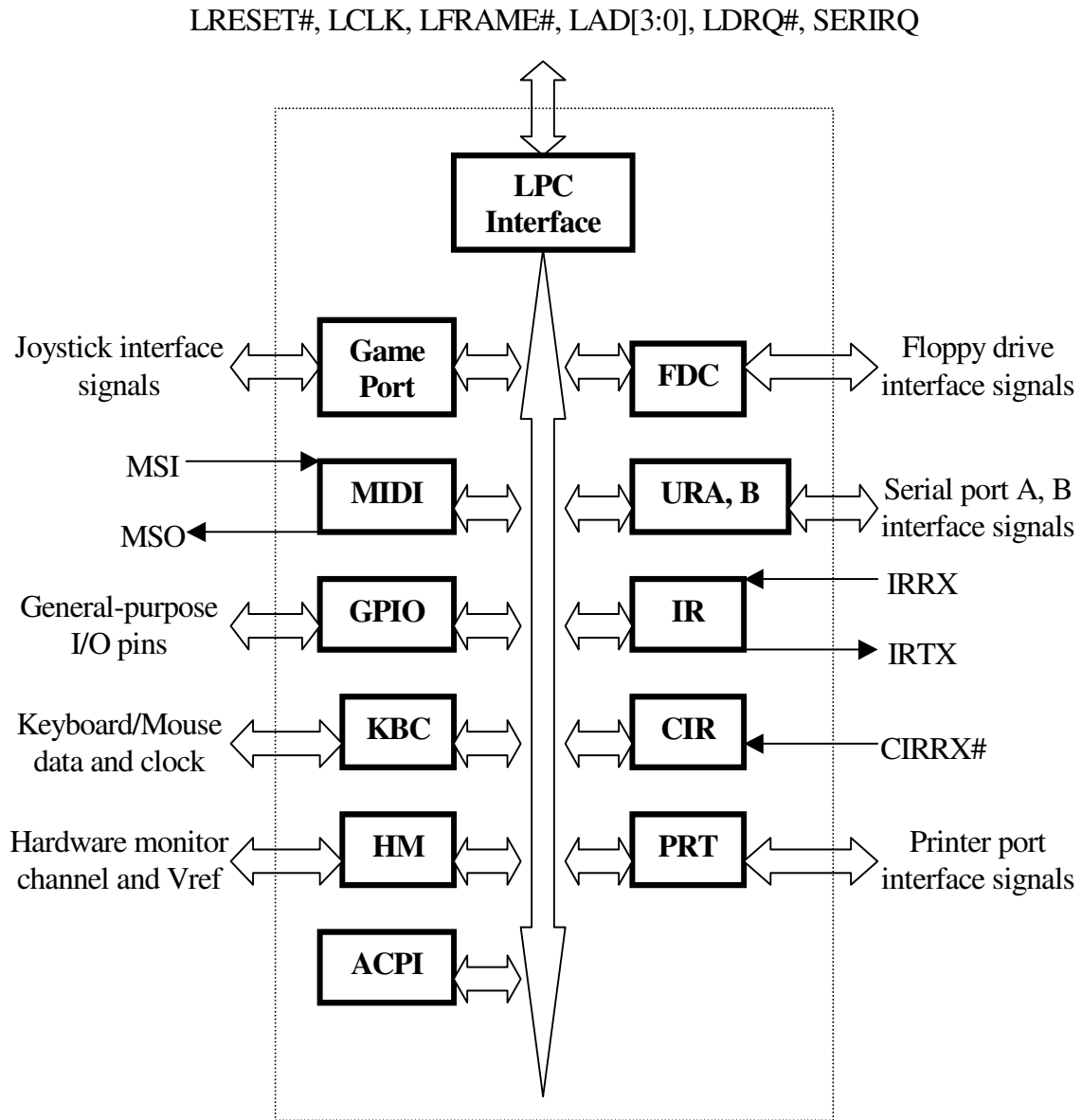

6. PIN CONFIGURATION for W83627HG-AW

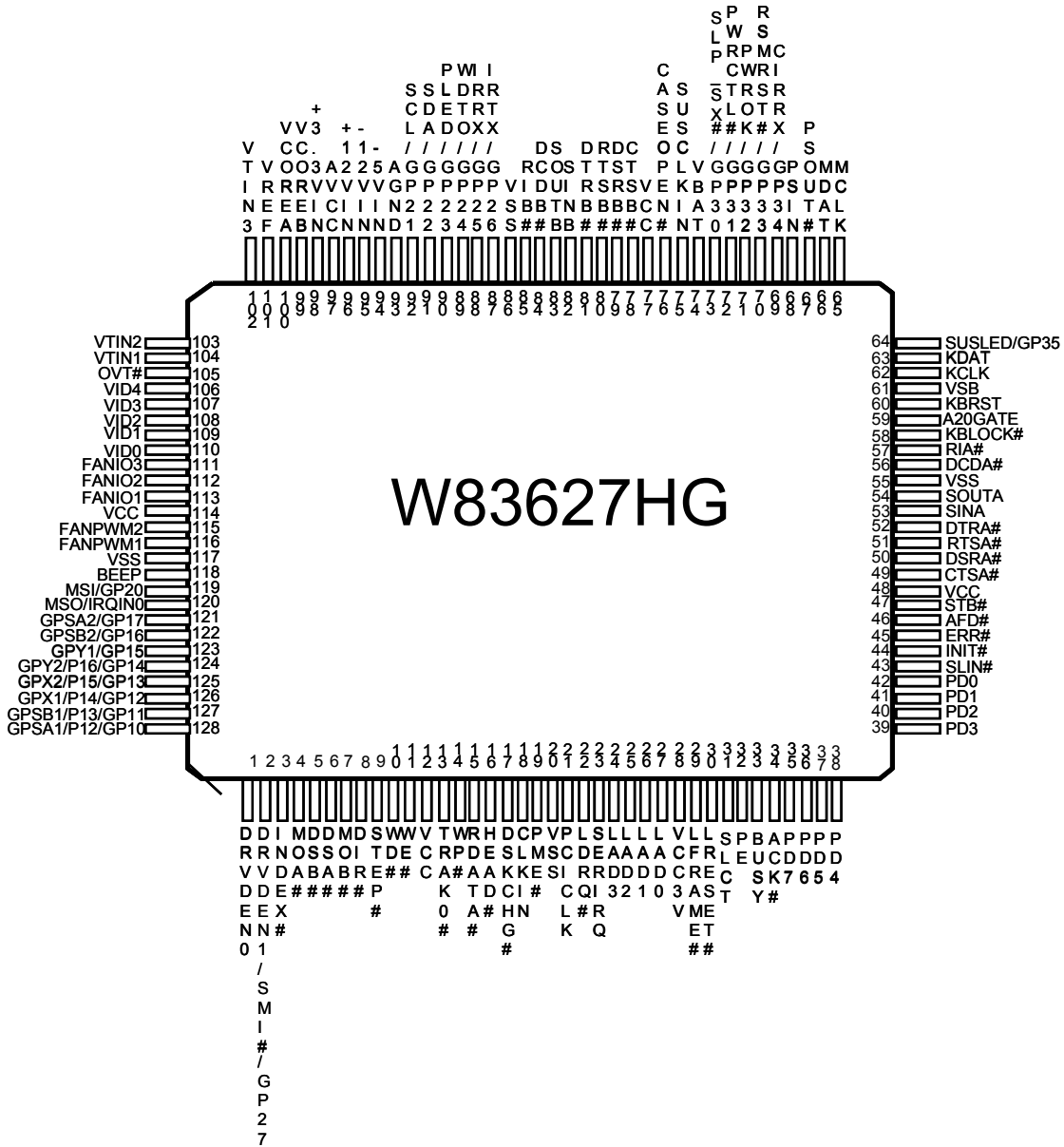

7. PIN DESCRIPTION

Type	Description
I/O _{8t}	TTL level bi-directional pin with 8mA source-sink capability
I/O _{12t}	TTL level bi-directional pin with 12mA source-sink capability
I/O _{24t}	TTL level bi-directional pin with 24 mA source-sink capability
I/O _{12tp3}	3.3V TTL level bi-directional pin with 12mA source-sink capability
I/O _{12ts}	TTL level Schmitt-trigger bi-directional pin with 12mA source-sink capability
I/O _{24ts}	TTL level Schmitt-trigger bi-directional pin with 24mA source-sink capability
I/O _{24tsp3}	3.3V TTL level Schmitt-trigger bi-directional pin with 24mA source-sink capability
I/OD _{12t}	TTL level bi-directional pin and open-drain output with 12mA sink capability
I/OD _{24t}	TTL level bi-directional pin and open-drain output with 24mA sink capability
I/OD _{12ts}	TTL level Schmitt-trigger bi-directional pin and open-drain output with 12mA sink capability
I/OD _{16ts}	TTL level Schmitt-trigger bi-directional pin and open-drain output with 16mA sink capability
I/OD _{24ts}	TTL level Schmitt-trigger bi-directional pin and open-drain output with 24mA sink capability
I/OD _{12cs}	CMOS level Schmitt-trigger bi-directional pin and open-drain output with 12mA sink capability
I/OD _{16cs}	CMOS level Schmitt-trigger bi-directional pin and open-drain output with 16mA sink capability
I/OD _{12csd}	CMOS level Schmitt-trigger bi-directional pin with internal pull down resistor and open-drain output with 12mA sink capability
I/OD _{12csu}	CMOS level Schmitt-trigger bi-directional pin with internal pull up resistor and open-drain output with 12mA sink capability
O ₄	Output pin with 4 mA source-sink capability
O ₈	Output pin with 8 mA source-sink capability
O ₁₂	Output pin with 12 mA source-sink capability
O ₁₆	Output pin with 16 mA source-sink capability
O ₂₄	Output pin with 24 mA source-sink capability
O _{12p3}	3.3V output pin with 12 mA source-sink capability
O _{24p3}	3.3V output pin with 24 mA source-sink capability
OD ₁₂	Open-drain output pin with 12 mA sink capability

1. Pin Description, Continued.

OD ₂₄	Open-drain output pin with 24 mA sink capability
OD _{12p3}	3.3V open-drain output pin with 12 mA sink capability
IN _t	TTL level input pin
IN _{tp3}	3.3V TTL level input pin
IN _{td}	TTL level input pin with internal pull down resistor
IN _{tu}	TTL level input pin with internal pull up resistor
IN _{ts}	TTL level Schmitt-trigger input pin
IN _{tsp3}	3.3V TTL level Schmitt-trigger input pin
IN _c	CMOS level input pin
IN _{cd}	CMOS level input pin with internal pull down resistor
IN _{cs}	CMOS level Schmitt-trigger input pin
IN _{csu}	CMOS level Schmitt-trigger input pin with internal pull up resistor

Note : Please refer to Section 11.2 DC CHARACTERISTICS for details.

7.1 LPC Interface

SYMBOL	PIN	I/O	FUNCTION
CLKIN	18	IN _{t3}	System clock input. According to the input frequency 24MHz or 48MHz, it is selectable through register. Default is 24MHz input.
PME#	19	OD _{12p3}	Generated PME event.
PCICLK	21	IN _{tsp3}	PCI clock input.
LDRQ#	22	O _{12p3}	Encoded DMA Request signal.
SERIRQ	23	I/O _{12tp3}	Serial IRQ input/Output.
LAD[3 : 0]	24-27	I/O _{12tp3}	These signal lines communicate address, control, and data information over the LPC bus between a host and a peripheral.
LFRAME#	29	IN _{tsp3}	Indicates start of a new cycle or termination of a broken cycle.
LRESET#	30	IN _{tsp3}	Reset signal. It can connect to PCIRST# signal on the host.
SUSCLKIN	75	IN _{tsp3}	32khz clock input , for CIR only.

7.2 FDC Interface

SYMBOL	PIN	I/O	FUNCTION
DRV DEN0	1	OD ₂₄	Drive Density Select bit 0.
DRV DEN1	2	OD ₁₂	Drive Density Select bit 1. (Default)
SMI#		OD ₁₂	System Management Interrupt
IRQIN1		IN _t	Interrupt channel input.
GP27		I/OD _{12t}	General purpose I/O port 2 bit 7.
INDEX#	3	IN _{csu}	This Schmitt-triggered input from the disk drive is active low when the head is positioned over the beginning of a track marked by an index hole. This input pin is pulled up internally by a 500 ohm resistor. The resistor can be disabled by bit 7 of LD0-CRF0 (FIPURDWN) .
MOA#	4	OD ₂₄	Motor A On. When set to 0, this pin enables disk drive 0.
DSB#	5	OD ₂₄	Drive Select B. When set to 0, this pin enables disk drive B.
DSA#	6	OD ₂₄	Drive Select A. When set to 0, this pin enables disk drive A.
MOB#	7	OD ₂₄	Motor B On. When set to 0, this pin enables disk drive 1.
DIR#	8	OD ₂₄	Direction of the head step motor. An open drain output. Logic 1 = outward motion Logic 0 = inward motion
STEP#	9	OD ₂₄	Step output pulses. This active low open drain output produces a pulse to move the head to another track.
WD#	10	OD ₂₄	Write data. This logic low open drain writes pre-compensation serial data to the selected FDD. An open drain output.
WE#	11	OD ₂₄	Write enable. An open drain output.
TRACK0#	13	IN _{csu}	Track 0. This Schmitt-triggered input from the disk drive is active low when the head is positioned over the outermost track. This input pin is pulled up internally by a 1 K ohm resistor. The resistor can be disabled by bit 7 of L0-CRF0 (FIPURDWN) .
WP#	14	IN _{csu}	Write protected. This active low Schmitt input from the disk drive indicates that the diskette is write-protected. This input pin is pulled up internally by a 1 K ohm resistor. The resistor can be disabled by bit 7 of L0-CRF0 (FIPURDWN) .
RDATA#	15	IN _{csu}	The read data input signal from the FDD. This input pin is pulled up internally by a 1 K ohm resistor. The resistor can be disabled by bit 7 of L0-CRF0 (FIPURDWN) .



7.2 FDC Interface, continued.

HEAD#	16	OD ₂₄	Head select. This open drain output determines which disk drive head is active. Logic 1 = side 0 Logic 0 = side 1
DSKCHG#	17	IN _{csu}	Diskette change. This signal is active low at power on and whenever the diskette is removed. This input pin is pulled up internally by a 1 K ohm resistor. The resistor can be disabled by bit 7 of L0-CRF0 (FIPURDWN).

7.3 Multi-Mode Parallel Port

The following pins have alternate functions (Printer Mode and Extension FDD Mode), which are selected by CR28 and LD1-CRF0 setting.

SYMBOL	PIN	I/O	FUNCTION
SLCT WE2#	31	IN _{ts} OD ₁₂	<p>PRINTER MODE :</p> <p>An active high input on this pin indicates that the printer is selected. Refer to the description of the parallel port for definition of this pin in ECP and EPP mode.</p> <p>EXTENSION FDD MODE :</p> <p>This pin is for Extension FDD B; its function is the same as the WE# pin of FDC.</p> <p>EXTENSION 2FDD MODE :</p> <p>This pin is for Extension FDD A and B; its function is the same as the WE# pin of FDC.</p>
PE WD2#	32	IN _{ts} OD ₁₂	<p>PRINTER MODE :</p> <p>An active high input on this pin indicates that the printer has detected the end of the paper. Refer to the description of the parallel port for the definition of this pin in ECP and EPP mode.</p> <p>EXTENSION FDD MODE :</p> <p>This pin is for Extension FDD B; its function is the same as the WD# pin of FDC.</p> <p>EXTENSION 2FDD MODE :</p> <p>This pin is for Extension FDD A and B; its function is the same as the WD# pin of FDC.</p>



7.3 Multi-Mode Parallel Port, continued.

SYMBOL	PIN	I/O	FUNCTION
BUSY	33	IN _{ts}	<p>PRINTER MODE :</p> <p>An active high input indicates that the printer is not ready to receive data. Refer to the description of the parallel port for definition of this pin in ECP and EPP mode.</p>
MOB2#		OD ₁₂	<p>EXTENSION FDD MODE :</p> <p>This pin is for Extension FDD B; its function is the same as the MOB# pin of FDC.</p> <p>EXTENSION 2FDD MODE :</p> <p>This pin is for Extension FDD A and B; its function is the same as the MOB# pin of FDC.</p>
ACK#	34	IN _{ts}	<p>PRINTER MODE :</p> <p>An active low input on this pin indicates that the printer has received data and is ready to accept more data. Refer to the description of the parallel port for the definition of this pin in ECP and EPP mode.</p>
DSB2#		OD ₁₂	<p>EXTENSION FDD MODE :</p> <p>This pin is for the Extension FDD B; its functions are the same as the DSB# pin of FDC.</p> <p>EXTENSION 2FDD MODE :</p> <p>This pin is for Extension FDD A and B; its function is the same as the DSB# pin of FDC.</p>
PD7	35	I/O _{12ts}	<p>PRINTER MODE : PD7</p> <p>Parallel port data bus bit 7. Refer to the description of the parallel port for the definition of this pin in ECP and EPP mode.</p>
DSA2#		OD ₁₂	<p>EXTENSION FDD MODE :</p> <p>This pin is a tri-state output.</p> <p>EXTENSION 2FDD MODE :</p> <p>This pin is for Extension FDD A; its function is the same as the DSA# pin of FDC.</p>

7.3 Multi-Mode Parallel Port, continued.

SYMBOL	PIN	I/O	FUNCTION
PD6 MOA2#	36	I/O _{12ts} OD ₁₂	<p>PRINTER MODE : PD6</p> <p>Parallel port data bus bit 6. Refer to the description of the parallel port for the definition of this pin in ECP and EPP mode.</p> <p>EXTENSION FDD MODE :</p> <p>This pin is a tri-state output.</p> <p>EXTENSION. 2FDD MODE : MOA2#</p> <p>This pin is for Extension FDD A; its function is the same as the MOA# pin of FDC.</p>
PD5	37	I/O _{12ts}	<p>PRINTER MODE : PD5</p> <p>Parallel port data bus bit 5. Refer to the description of the parallel port for the definition of this pin in ECP and EPP mode.</p> <p>EXTENSION FDD MODE :</p> <p>This pin is a tri-state output.</p> <p>EXTENSION 2FDD MODE :</p> <p>This pin is a tri-state output.</p>
PD4 DSKCHG2#	38	I/O _{12ts} IN _{ts}	<p>PRINTER MODE : PD4</p> <p>Parallel port data bus bit 4. Refer to the description of the parallel port for the definition of this pin in ECP and EPP mode.</p> <p>EXTENSION FDD MODE :</p> <p>This pin is for Extension FDD B; the function of this pin is the same as the DSKCHG# pin of FDC. It is pulled high internally.</p> <p>EXTENSION 2FDD MODE :</p> <p>This pin is for Extension FDD A and B; this function of this pin is the same as the DSKCHG# pin of FDC. It is pulled high internally.</p>



7.3 Multi-Mode Parallel Port, continued.

SYMBOL	PIN	I/O	FUNCTION
PD3 RDATA2#	39	I/O _{12ts} IN _{ts}	<p>PRINTER MODE : PD3</p> <p>Parallel port data bus bit 3. Refer to the description of the parallel port for the definition of this pin in ECP and EPP mode.</p> <p>EXTENSION FDD MODE : RDATA2#</p> <p>This pin is for Extension FDD B; its function is the same as the RDATA# pin of FDC. It is pulled high internally.</p> <p>EXTENSION 2FDD MODE : RDATA2#</p> <p>This pin is for Extension FDD A and B; its function is the same as the RDATA# pin of FDC. It is pulled high internally.</p>
PD2 WP2#	40	I/O _{12ts} IN _{ts}	<p>PRINTER MODE : PD2</p> <p>Parallel port data bus bit 2. Refer to the description of the parallel port for the definition of this pin in ECP and EPP mode.</p> <p>EXTENSION FDD MODE : WP2#</p> <p>This pin is for Extension FDD B; its function is the same as the WP# pin of FDC. It is pulled high internally.</p> <p>EXTENSION. 2FDD MODE : WP2#</p> <p>This pin is for Extension FDD A and B; its function is the same as the WP# pin of FDC. It is pulled high internally.</p>
PD1 TRAK02#	41	I/O _{12ts} IN _{ts}	<p>PRINTER MODE : PD1</p> <p>Parallel port data bus bit 1. Refer to the description of the parallel port for the definition of this pin in ECP and EPP mode.</p> <p>EXTENSION FDD MODE : TRAK02#</p> <p>This pin is for Extension FDD B; its function is the same as the TRAK0# pin of FDC. It is pulled high internally.</p> <p>EXTENSION. 2FDD MODE : TRAK02#</p> <p>This pin is for Extension FDD A and B; its function is the same as the TRAK0# pin of FDC. It is pulled high internally.</p>
PD0 INDEX2#	42	I/O _{12ts} IN _{ts}	<p>PRINTER MODE : PD0</p> <p>Parallel port data bus bit 0. Refer to the description of the parallel port for the definition of this pin in ECP and EPP mode.</p> <p>EXTENSION FDD MODE :</p> <p>This pin is for Extension FDD B; its function is the same as the INDEX# pin of FDC. It is pulled high internally.</p> <p>EXTENSION 2FDD MODE :</p> <p>This pin is for Extension FDD A and B; its function is the same as the INDEX# pin of FDC. It is pulled high internally.</p>

7.3 Multi-Mode Parallel Port, continued.

SYMBOL	PIN	I/O	FUNCTION
SLIN#	43	OD ₁₂	PRINTER MODE : SLIN# Output line for detection of printer selection. Refer to the description of the parallel port for the definition of this pin in ECP and EPP mode.
STEP2#		OD ₁₂	EXTENSION FDD MODE : This pin is for Extension FDD B; its function is the same as the STEP# pin of FDC. EXTENSION 2FDD MODE : This pin is for Extension FDD A and B; its function is the same as the STEP# pin of FDC.
INIT#	44	OD ₁₂	PRINTER MODE : Output line for the printer initialization. Refer to the description of the parallel port for the definition of this pin in ECP and EPP mode.
DIR2#		OD ₁₂	EXTENSION FDD MODE : This pin is for Extension FDD B; its function is the same as the DIR# pin of FDC. EXTENSION 2FDD MODE : This pin is for Extension FDD A and B; its function is the same as the DIR# pin of FDC.
ERR#	45	IN _{ts}	PRINTER MODE : An active low input on this pin indicates that the printer has encountered an error condition. Refer to the description of the parallel port for the definition of this pin in ECP and EPP mode.
HEAD2#		OD ₁₂	EXTENSION FDD MODE : This pin is for Extension FDD B; its function is the same as the HEAD# pin of FDC. EXTENSION 2FDD MODE : This pin is for Extension FDD A and B; its function is the same as the HEAD# pin of FDC.



7.3 Multi-Mode Parallel Port, continued.

SYMBOL	PIN	I/O	FUNCTION
AFD#	46	OD ₁₂	<p>PRINTER MODE :</p> <p>An active low output from this pin causes the printer to auto feed a line after a line is printed. Refer to the description of the parallel port for the definition of this pin in ECP and EPP mode.</p>
DRV DEN0		OD ₁₂	<p>EXTENSION FDD MODE :</p> <p>This pin is for Extension FDD B; its function is the same as the DRV DEN0 pin of FDC.</p> <p>EXTENSION 2FDD MODE :</p> <p>This pin is for Extension FDD A and B; its function is the same as the DRV DEN0 pin of FDC.</p>
STB#	47	OD ₁₂	<p>PRINTER MODE :</p> <p>An active low output is used to latch the parallel data into the printer. Refer to the description of the parallel port for the definition of this pin in ECP and EPP mode.</p> <p>EXTENSION FDD MODE :</p> <p>This pin is a tri-state output</p> <p>EXTENSION 2FDD MODE :</p> <p>This pin is a tri-state output.</p>

7.4 Serial Port Interface

SYMBOL	PIN	I/O	FUNCTION
CTSA# CTSB#	49 78	IN _t	Clear To Send. It is the modem control input. The function of these pins can be tested by reading bit 4 of the handshake status register.
DSRA# DSRB#	50 79	IN _t	Data Set Ready. An active low signal indicates the modem or data set is ready to establish a communication link and transfer data to the UART.
RTSA# HEFRAS	51	O _{8C} IN _{cd}	UART A Request To Send. An active low signal informs the modem or data set that the controller is ready to send data. During power-on reset, this pin is pulled down internally and is defined as HEFRAS, which provides the power-on value for CR26 bit 6 (HEFRAS). A 4.7 k ohm is recommended if intends to pull up. (select 4EH as configuration I/O port's address)
DTRA# PNPCVS#	52	O _{8C} IN _{cd}	UART B Request To Send. An active low signal informs the modem or data set that the controller is ready to send data. During power-on reset, this pin is pulled down internally and is defined as PNPCVS#, which provides the power-on value for CR24 bit 0, A 4.7k ohm is recommended if intends to pull up. (This bit is used to clear the default value of FDC, UARTs, and LPT setting)
RTSB#	80	O _{8C}	UART B Request To Send. An active low signal informs the modem or data set that the controller is ready to send data.
DTRB#	81	O _{8C}	UART B Data Terminal Ready. An active low signal informs the modem or data set that controller is ready to communicate.
SINA SINB#	53 82	IN _t	Serial Input. It is used to receive serial data through the communication link.
SOUTA PENKBC	54	O _{8C} IN _{cd}	UART A Serial Output. It is used to transmit serial data out to the communication link. During power-on reset, this pin is pulled down internally and is defined as PENKBC, which provides the power-on value for CR24 bit 2 (PENKBC). A 4.7 k ohm resistor is recommended if intends to pull up. (enable KBC)
SOUTB PEN48	83	O _{8C} IN _{cd}	UART B Serial Output. During power-on reset, this pin is pulled down internally and is defined as PEN48, which provides the power-on value for CR24 bit 6 (PEN48). A 4.7 k ohm resistor is recommended if intends to pull up.

7.4 Serial Port Interface, continued.

SYMBOL	PIN	I/O	FUNCTION
DCDA# DCDB#	56 84	IN _t	Data Carrier Detect. An active low signal indicates the modem or data set has detected a data carrier.
RIA# RIB#	57 85	IN _t	Ring Indicator. An active low signal indicates that a ring signal is being received from the modem or data set.

7.5 KBC Interface

SYMBOL	PIN	I/O	FUNCTION
KBLOCK#	58	IN _{tu}	Keyboard inhibits control input. This pin is active after system reset. Internal pull high. (KBC P17)
GA20M	59	O ₁₆	Gate A20 output. This pin is high after system reset. (KBC P21)
KBRST	60	O ₁₆	Keyboard reset. This pin is high after system reset. (KBC P20)
KCLK	62	I/OD _{16ts} I/OD _{16cs}	Keyboard Clock. For G and J version, this pin is CMOS level. For UD-Mask A-version, this pin is TTL level.
KDAT	63	I/OD _{16ts} I/OD _{16cs}	Keyboard Data. For G and J version, this pin is CMOS level. For UD-Mask A-version, this pin is TTL level.
MCLK	65	I/OD _{16ts} I/OD _{16cs}	PS2 Mouse Clock. For G and J version, this pin is CMOS level. For UD-Mask A-version, this pin is TTL level.
MDAT	66	I/OD _{16ts} I/OD _{16cs}	PS2 Mouse Data. For G and J version, this pin is CMOS level. For UD-Mask A-version, this pin is TTL level.

7.6 ACPI Interface

SYMBOL	PIN	I/O	FUNCTION
PSOUT#	67	OD ₁₂	Panel Switch Output. This signal is used for Wake-Up system from S5 _{cold} state. This pin is pulse output, active low.
PSIN	68	IN _{cd}	Panel Switch Input. This pin is high active with an internal pull down resistor.
VBAT	74	PWR	Battery voltage input.

7.7 Hardware Monitor Interface

(For W83627HG only, all these pins in W83627G are NC.)

SYMBOL	PIN	I/O	FUNCTION
CASEOPEN#	76	IN _t	CASE OPEN. An active low input from an external device when case is opened. This signal can be latched if pin VBAT is connect to battery, even W83627HG is power off.
-5VIN	94	AIN	0V to 4.096V FSR Analog Inputs.
-12VIN	95	AIN	0V to 4.096V FSR Analog Inputs.
+12VIN	96	AIN	0V to 4.096V FSR Analog Inputs.
+3.3VIN	98	AIN	0V to 4.096V FSR Analog Inputs.
VCOREB	99	AIN	0V to 4.096V FSR Analog Inputs.
VCOREA	100	AIN	0V to 4.096V FSR Analog Inputs.
VREF	101	PWR	Reference Voltage for temperature measurement.
VTIN3	102	AIN	Temperature sensor 3 input. It is used for temperature measurement.
VTIN2	103	AIN	Temperature sensor 2 input. It is used for CPU1 temperature measurement.
VTIN1	104	AIN	Temperature sensor 1 input. It is used for system temperature measurement.
OVT#	105	OD ₂₄	Over temperature Shutdown Output. It indicated the VTIN2 or VTIN3 is over temperature limit.
VID[4 : 0]	106-110	IN _t	Voltage Supply readouts from Pentium II.
FANIO[3 : 1]	111-113	I/O _{12ts}	0V to +5V amplitude fan tachometer input. Alternate Function : Fan on-off control output. These multifunctional pins can be programmable input or output.
FANPWM1 FANPWM2	116 115	O ₁₂	Fan speed control. Use the Pulse Width Modulation (PWM) technic knowledge to control the Fan's RPM.
BEEP	118	OD ₁₂	Beep function for hardware monitor. This pin is low after system reset.

7.8 Game Port & MIDI Port

SYMBOL	PIN	I/O	FUNCTION
MSI GP20	119	INtu I/OD _{12t}	MIDI serial data input . (Default) General purpose I/O port 2 bit 0.
MSO IRQIN0	120	O8c Inc	MIDI serial data output. (Default) Alternate Function input : Interrupt channel input.
GPSA2 GP17	121	INcsu I/OD _{12csu}	Active-low, Joystick I switch input 2. This pin has an internal pull-up resistor. (Default) General purpose I/O port 1 bit 7.
GPSB2 GP16	122	INcsu I/OD _{12csu}	Active-low, Joystick II switch input 2. This pin has an internal pull-up resistor. (Default) General purpose I/O port 1 bit 6.
GPY1 GP15	123	I/OD _{12csd} I/OD _{12cs}	Joystick I timer pin. This pin connects to Y positioning variable resistors for the Joystick. (Default) General purpose I/O port 1 bit 5.
GPY2 GP14 P16	124	I/OD _{12csd} I/OD _{12cs}	Joystick II timer pin. This pin connects to Y positioning variable resistors for the Joystick. (Default) General purpose I/O port 1 bit 4. Alternate Function Output : KBC P16 I/O port.
GPX2 GP13 P15	125	I/OD _{12csd} I/OD _{12cs}	Joystick II timer pin. This pin connects to X positioning variable resistors for the Joystick. (Default) General purpose I/O port 1 bit 3. Alternate Function Output : KBC P15 I/O port.
GPX1 GP12 P14	126	I/OD _{12csd} I/OD _{12cs}	Joystick I timer pin. This pin connects to X positioning variable resistors for the Joystick. (Default) General purpose I/O port 1 bit 2. Alternate Function Output : KBC P14 I/O port.
GPSB1 GP11 P13	127	INcsu I/OD _{12csu}	Active-low, Joystick II switch input 1. (Default) General purpose I/O port 1 bit 1. Alternate Function Output : KBC P13 I/O port.
GPSA1 GP10 P12	128	INcsu I/OD _{12csu}	Active-low, Joystick I switch input 1. (Default) General purpose I/O port 1 bit 0. Alternate Function Output : KBC P12 I/O port.

7.9 General Purpose I/O Port

7.9.1 General Purpose I/O Port 1 (Power source is Vcc)

See section 7.8

7.9.2 General Purpose I/O Port 2 (Power source is Vcc)

SYMBOL	PIN	I/O	FUNCTION
GP20 MSI	119	I/OD _{12t} IN _t	General purpose I/O port 2 bit 0. MIDI serial data input. Schmitt trigger input with internal pull-up resistor.
GP21 SCL	92	I/OD _{12t} IN _{ts}	General purpose I/O port 2 bit 1. Serial Bus Clock. (available for W83627HG only)
GP22 SDA	91	I/OD _{12t} I/OD _{12ts}	General purpose I/O port 2 bit 2. Serial Bus Data. (available for W83627HG only)
GP23 PLED	90	I/OD _{12t} OD ₁₂	General purpose I/O port 2 bit 3. Power LED output, this signal will be logical low after system reset.
GP24 WDTO	89	I/OD _{12t} O ₁₂	General purpose I/O port 2 bit 4. Watch Dog Timer Output. High level indicates that Watch Dog Timer time-out occurs.
GP25 IRRX	88	I/OD _{12t} IN _{ts}	General purpose I/O port 2 bit 5. Infrared Receiver Input.
GP26 IRTX	87	I/OD _{12t} O ₁₂	General purpose I/O port 2 bit 6. Infrared Transmitter Output.
GP27 SMI# (IRQIN1) DRVDEN1	2	I/OD _{24t} OD ₂₄ IN _t OD ₂₄	General purpose I/O port 2 bit 7. System Management Interrupt. (Interrupt channel input. For C version only) Drive Density Select bit 1. (Default)

7.9.3 General Purpose I/O Port 3 (Power source is VSB)

SYMBOL	PIN	I/O	FUNCTION
GP30 SLP_SX#	73	I/OD _{12t} IN _{ts}	General purpose I/O port 3 bit 0. Chipset suspend C status input.
GP31 PWRCTL#	72	I/OD _{12t} O ₁₂	General purpose I/O port 3 bit 1. Power On Control. Active low signal that informs system to turn main power.
GP32 PWROK	71	I/OD _{12t} OD ₁₂	General purpose I/O port 3 bit 2. Power OK. Active (High) level indicates VDD is ready.
GP33 RSMRST#	70	I/OD _{12t} OD ₁₂	General purpose I/O port 3 bit 3. Resume Reset. Active (High) level indicates VSB is ready.
GP34 CIRRX#	69	I/OD _{12t} IN _{ts}	General purpose I/O port 3 bit 4. Consumer IR receiving input. This pin can Wake-Up system from S5 _{cold} . (Default)
GP35 SUSLED	64	I/OD _{24t} O ₂₄	General purpose I/O port 3 bit 5. Suspend LED output, it can program to flash when suspend state. This function can work without VCC. (Default)

7.10 POWER PINS

SYMBOL	PIN	FUNCTION
VCC	12, 48, 77, 114	+5V power supply for the digital circuitry.
VSB	61	+5V stand-by power supply for the digital circuitry. Do not leave this pin unconnected. Connect it to VCC if the system does not provide standby power
VCC3V	28	+3.3V power supply for driving 3V on host interface.
AVCC	97	Analog VCC input. Internally supplier to all analog circuitry.
AGND	93	Internally connected to all analog circuitry. The ground reference for all analog inputs..
VSS	20, 55, 86, 117	Ground.

8. Hardware monitor

8.1 General Description

The W83627HG can be used to monitor several critical hardware parameters of the system, including power supply voltages, fan speeds, and temperatures, which are very important for a high-end computer system to work stable and properly. W83627HG provides both LPC and I²C™ serial bus interface to access hardware.

An 8-bit analog-to-digital converter (ADC) was built inside W83627HG. The W83627HG can simultaneously monitor 9 analog voltage inputs, 3 fan tachometer inputs, 3 remote temperature, one case-open detection signal. The remote temperature sensing can be performed by thermistors, or 2N3904 NPN-type transistors, or directly from Intel™ Deschutes CPU thermal diode output. Also the W83627HG provides : 2 PWM (pulse width modulation) outputs for the fan speed control; beep tone output for warning; SMI# (through serial IRQ) , OVT#, GPO# signals for system protection events.

Through the application software or BIOS, the users can read all the monitored parameters of system from time to time. And a pop-up warning can be also activated when the monitored item was out of the proper/preset range. The application software could be Winbond's Hardware Doctor™, or Intel™ LDCM (LanDesk Client Management) , or other management application software. Also the users can set up the upper and lower limits (alarm thresholds) of these monitored parameters and to activate one programmable and maskable interrupts. An optional beep tone could be used as warning signal when the monitored parameters are out of the preset range.

Additionally, 5 VID inputs are provided to read the VID of CPU (i.e. Pentium™ II) if applicable. This is to provide the Vcore voltage correction automatically. Also W83627HG uniquely provides an optional feature : early stage (before BIOS was loaded) beep warning. This is to detect if the fatal elements present --- Vcore or +3.3V voltage fail, and the system can not be boomed up.

8.2 Access Interface

The W83627HG provides two interface for microprocessor to read/write hardware monitor internal registers.

8.2.1 LPC interface

The first interface uses LPC Bus to access which the ports of low byte (bit2~bit0) are defined in the port 5h and 6h. The other higher bits of these ports is set by W83627HG itself. The general decoded address is set to port 295h and port 296h. These two ports are described as following :

Port 295h : Index port.

Port 296h : Data port.

The register structure is showed as the Figure 8.1

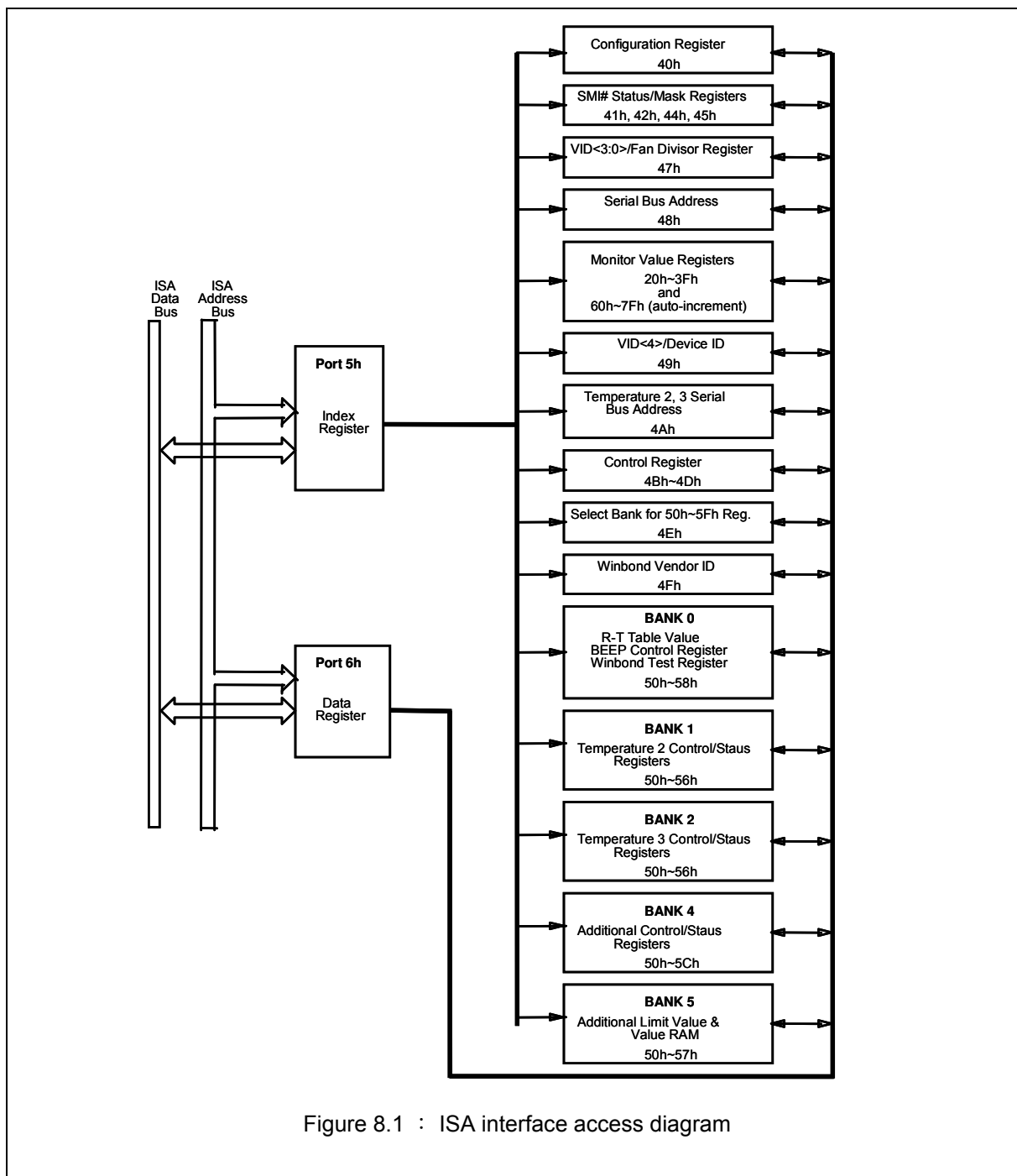

Figure 8.1 : ISA interface access diagram

8.2.1.1. I²C interface

The second interface uses I²C Serial Bus. W83627HG hardware monitor has three serial bus address. That is, the first address defined at CR[48h] can read/write all registers excluding Bank 1 and Bank 2 temperature sensor 2/3 registers. The second address defined at CR[4Ah] bit2-0 only read/write temperature sensor 2 registers, and the third address defined at CR[4Ah] bit6-4 only can access (read/write) temperature sensor 3 registers.

8.2.1.1.1 The first serial bus access timing is shown as follow :

(a) Serial bus write to internal address register followed by the data byte

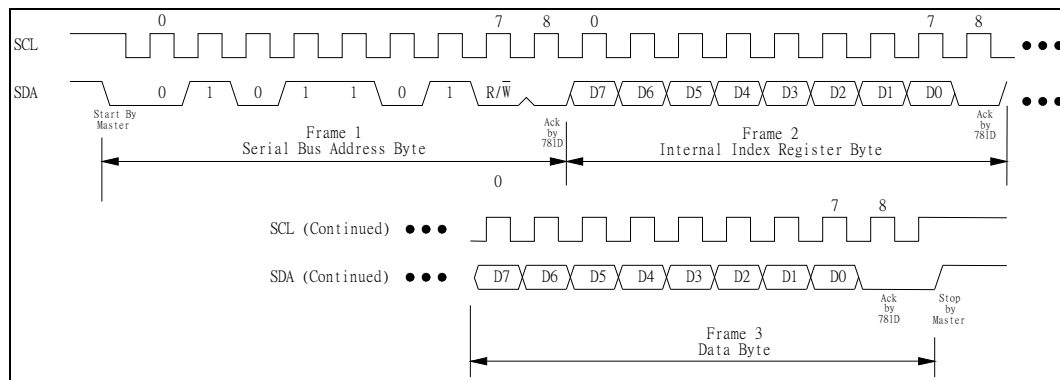

(b) Serial bus write to internal address register only

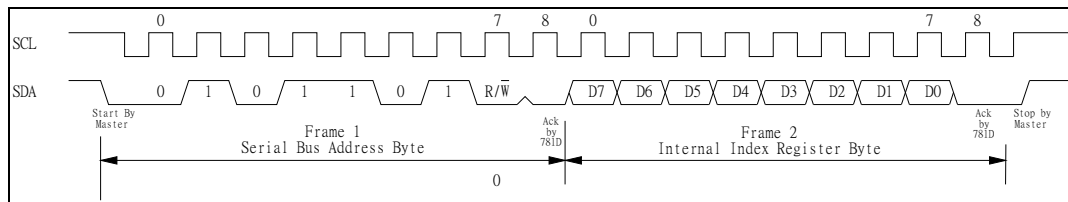

(c) Serial bus read from a register with the internal address register prefer to desired location

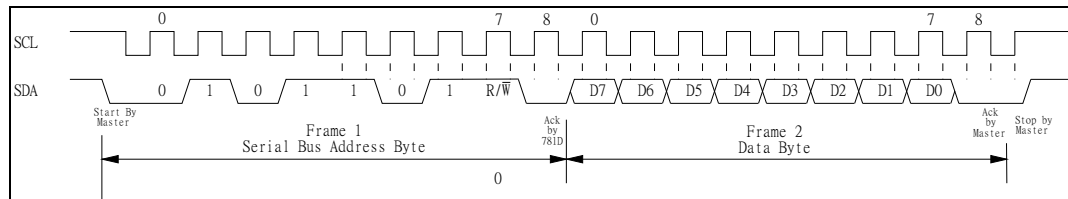

8.2.1.1.2 The serial bus timing of the temperature 2 and 3 are shown as follow :

(a) Typical 2-byte read from preset pointer location (Temp, T_{OS} , T_{HYST})

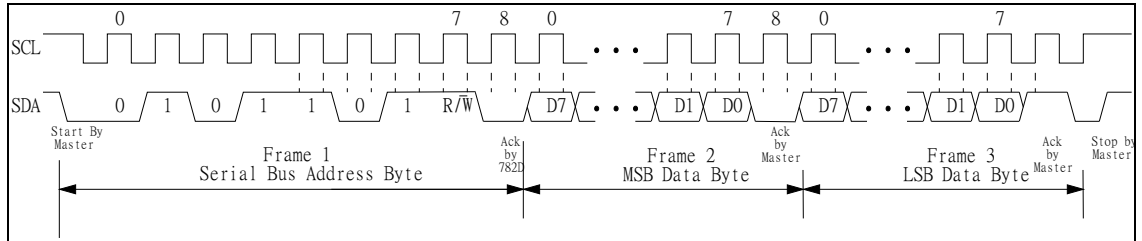

(b) Typical pointer set followed by immediate read for 2-byte register (Temp, T_{OS} , T_{HYST})

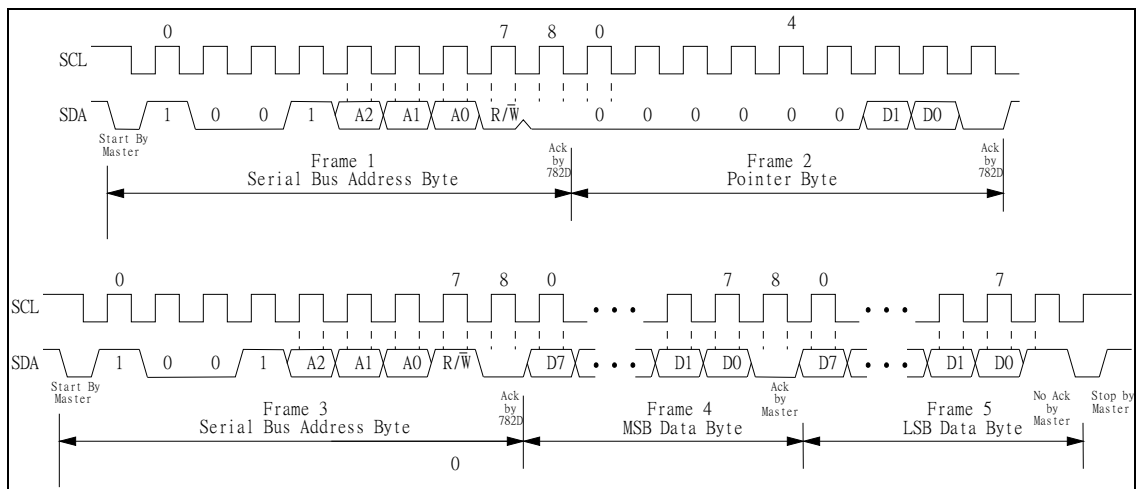

(c) Typical read 1-byte from configuration register with preset pointer

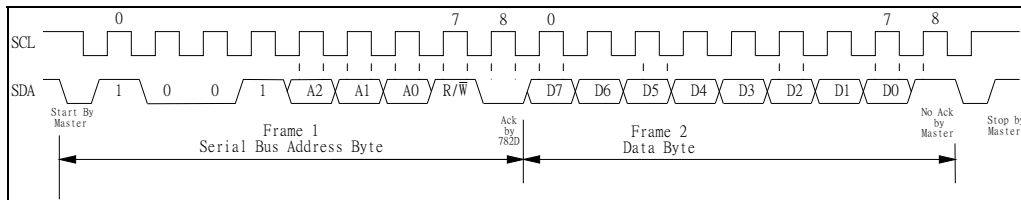

8.3 Analog Inputs

The maximum input voltage of the analog pin is 4.096V because the 8-bit ADC has a 16mV LSB. Really, the application of the PC monitoring would most often be connected to power suppliers. The CPU V-core voltage, +3.3V, battery and 5VSB voltage can directly connected to these analog inputs. The +12V, -12V and -5V voltage inputs should be reduced a factor with external resistors so as to obtain the input range. As Figure 8.2 shows.

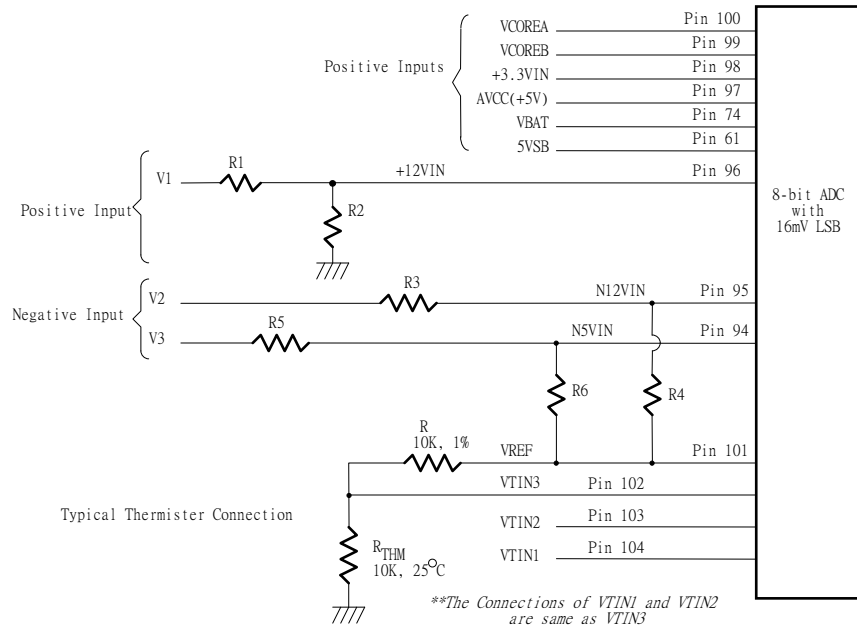

Figure 8.2

8.3.1 Monitor over 4.096V voltage :

The input voltage +12VIN can be expressed as following equation.

$$12VIN = V_1 \times \frac{R_2}{R_1 + R_2}$$

The value of R1 and R2 can be selected to 28K Ohms and 10K Ohms, respectively, when the input voltage V1 is 12V. The node voltage of +12VIN can be subject to less than 4.096V for the maximum input range of the 8-bit ADC. The Pin 97 is connected to the power supply VCC with +5V. There are two functions in this pin with 5V. The first function is to supply internal analog power in the W83627HG and the second function is that this voltage with 5V is connected to internal serial resistors to monitor the +5V voltage. The values of two serial resistors are 34K ohms and 50K ohms so that input voltage to ADC is 2.98V which is less than 4.096V of ADC maximum input voltage. The express equation can represent as follows.

$$V_{in} = VCC \times \frac{50K\Omega}{50K\Omega + 34K\Omega} \cong 2.98V$$

where VCC is set to 5V.

The Pin 61 is connected to 5VSB voltage. W83627HG monitors this voltage and the internal two serial resistors are 17K Ω and 33K Ω so that input voltage to ADC is 3.3V which less than 4.096V of ADC maximum input voltage.

8.3.2 Monitor negative voltage :

The negative voltage should be connected two series resistors and a positive voltage VREF (is equal to 3.6V) . In the Figure 8.2, the voltage V2 and V3 are two negative voltage which they are -12V and -5V respectively. The voltage V2 is connected to two serial resistors then is connected to another terminal VREF which is positive voltage. So as that the voltage node N12VIN can be obtain a posedge voltage if the scales of the two serial resirtors are carefully selected. It is recom-manded from Winbond that the scale of two serial resistors are R3=232K ohm and R4=56K ohm. The input voltage of node N12VIN can be calculated by following equation.

$$N12VIN = (VREF + |V_2|) \times \left(\frac{232K\Omega}{232K\Omega + 56K\Omega} \right) + V_2$$

Where VREF is equal 3.6V.

If the V2 is equal to -12V then the voltage is equal to 0.567V and the converted hexadecimal data is set to 35h by the 8-bit ADC with 16mV-LSB. This monitored value should be converted to the real negative vottage and the express equation is shown as follows.

$$V_2 = \frac{N12VIN - VREF \times \beta}{1 - \beta}$$

Where β is 232K / (232K+56K) . If the N2VIN is 0.567 then the V2 is approximately equal to -12V.

The another negative voltage input V3 (approximate -5V) also can be evaluated by the similar method and the serial resistors can be selected with R5=120K ohms and R6=56K ohms by the Winbond recommended. The expression equation of V3 With -5V voltage is shown as follows.

$$V_3 = \frac{N5VIN - VREF \times \gamma}{1 - \gamma}$$

Where the γ is set to 120K / (120K+56K) . If the monitored ADC value in the N5VIN channel is 0.8635, VREF is 3.6V and the parameter γ is 0.6818 then the negative voltage of V3 can be evalated to be -5V.

8.3.3 Temperature Measurement Machine

The temperature data format is 8-bit two's-complement for sensor 2 and 9-bit two's-complement for sensor 1. The 8-bit temperature data can be obtained by reading the CR[27h]. The 9-bit temperature data can be obtained by reading the 8 MSBs from the Bank1 CR[50h] and the LSB from the Bank1 CR[51h] bit 7. The format of the temperature data is show in Table 1.

Temperature	8-Bit Digital Output		9-Bit Digital Output	
	8-Bit Binary	8-Bit Hex	9-Bit Binary	9-Bit Hex
+125°C	0111,1101	7Dh	0,1111,1010	0FAh
+25°C	0001,1001	19h	0,0011,0010	032h
+1°C	0000,0001	01h	0,0000,0010	002h
+0.5°C	-	-	0,0000,0001	001h
+0°C	0000,0000	00h	0,0000,0000	000h
-0.5°C	-	-	1,1111,1111	1FFh
-1°C	1111,1111	FFh	1,1111,1110	1FFh
-25°C	1110,0111	E7h	1,1100,1110	1CEh
-55°C	1100,1001	C9h	1,1001,0010	192h

Table 2.

8.3.3.1. Monitor temperature from thermistor :

The W83627HG can connect three thermistors to measure three different envirement temperature. The specification of thermistor should be considered to (1) β value is 3435K, (2) resistor value is 10K ohms at 25°C. In the Figure 8.2, the themistor is connected by a serial resistor with 10K Ohms, then connect to VREF (Pin 101) .

8.3.3.2. Monitor temperature from Pentium IITM thermal diode or bipolar transistor 2N3904

The W83627HG can alternate the thermistor to Pentium IITM (Deschutes) thermal diode interface or transistor 2N3904 and the circuit connection is shown as Figure 8.3. The pin of Pentium IITM D- is connected to power supply ground (GND) and the pin D+ is connected to pin VTINx in the W83627HG. The resistor R=30K ohms should be connected to VREF to supply the diode bias current and the bypass capacitor C=3300pF should be added to filter the high frequency noise. The transistor 2N3904 should be connected to a form with a diode, that is, the Base (B) and Collector (C) in the 2N3904 should be tied together to act as a thermal diode.

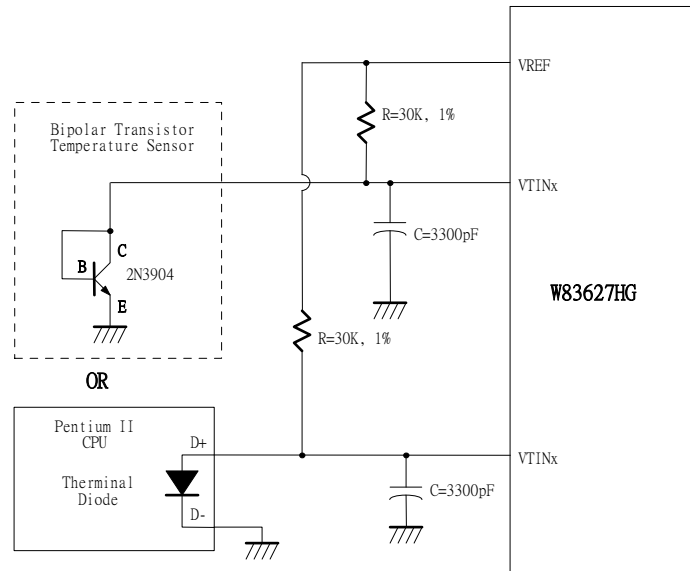

Figure 8.3

8.4 2.4 FAN Speed Count and FAN Speed Control

8.4.1 Fan speed count

Inputs are provided for signals from fans equipped with tachometer outputs. The level of these signals should be set to TTL level, and maximum input voltage can not be over +5.5V. If the input signals from the tachometer outputs are over the VCC, the external trimming circuit should be added to reduce the voltage to obtain the input specification. The normal circuit and trimming circuits are shown as Figure 8.4.

Determine the fan counter according to :

$$\text{Count} = \frac{1.35 \times 10^6}{\text{RPM} \times \text{Divisor}}$$

In other words, the fan speed counter has been read from register CR28 or CR29 or CR2A, the fan speed can be evaluated by the following equation.

$$\text{RPM} = \frac{1.35 \times 10^6}{\text{Count} \times \text{Divisor}}$$

The default divisor is 2 and defined at CR47.bit7~4, CR4B.bit7~6, and Bank0 CR5D.bit5~7 which are three bits for divisor. That provides very low speed fan counter such as power supply fan. The followed table is an example for the relation of divisor, PRM, and count.

Divisor	Nominal PRM	Time per Revolution	Counts	70% RPM	Time for 70%
1	8800	6.82 ms	153	6160	9.74 ms
2 (default)	4400	13.64 ms	153	3080	19.48 ms
4	2200	27.27 ms	153	1540	38.96 ms
8	1100	54.54 ms	153	770	77.92 ms
16	550	109.08 ms	153	385	155.84 ms
32	275	218.16 ms	153	192	311.68 ms
64	137	436.32 ms	153	96	623.36 ms
128	68	872.64 ms	153	48	1246.72 ms

Table 1.

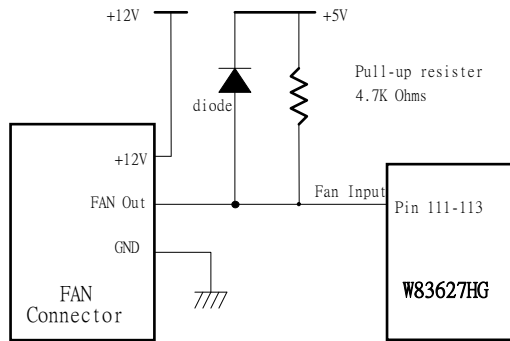

Fan with Tach Pull-Up to +5V

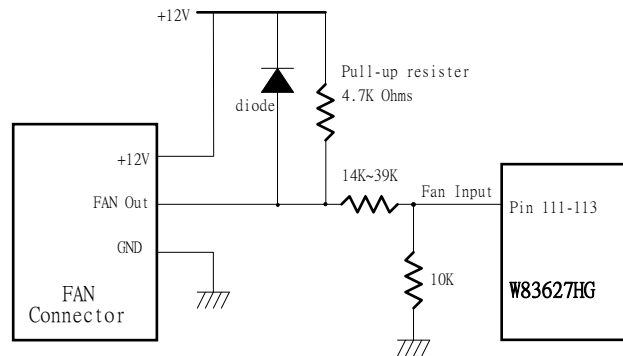

Fan with Tach Pull-Up to +12V, or Totem-Pole Output and Register Attenuator

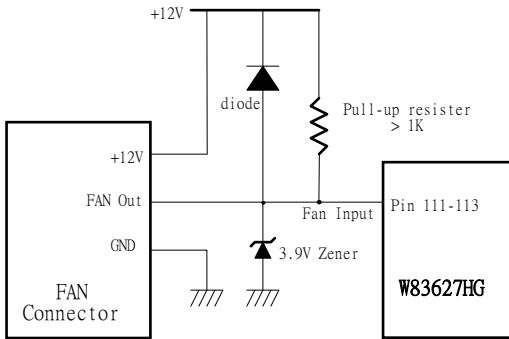

Fan with Tach Pull-Up to +12V and Zener Clamp

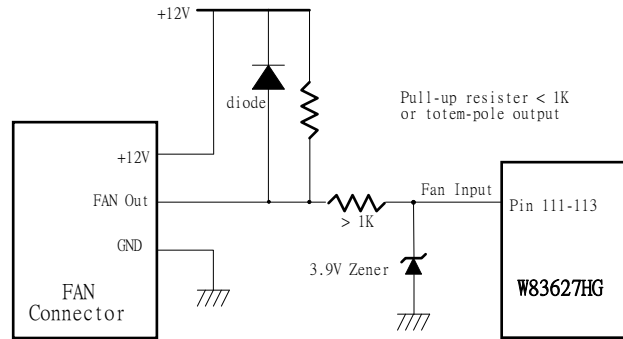

Fan with Tach Pull-Up to +12V, or Totem-Pole Output and Zener Clamp

Figure 8.4

8.4.2 Fan speed control

The W83627HG provides 2 sets for fan PWM speed control. The duty cycle of PWM can be programmed by a 8-bit registers which are defined in the Bank0 CR5A and CR5B. The default duty cycle is set to 100%, that is, the default 8-bit registers is set to FFh. The expression of duty can be represented as follows.

$$\text{Duty - cycle(\%)} = \frac{\text{Programmed 8 - bit Register Value}}{255} \times 100\%$$

The PWM clock frequency also can be program and defined in the Bank0.CR5C. The application circuit is shown as follows.

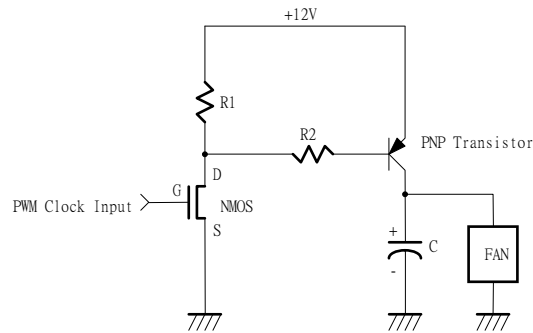
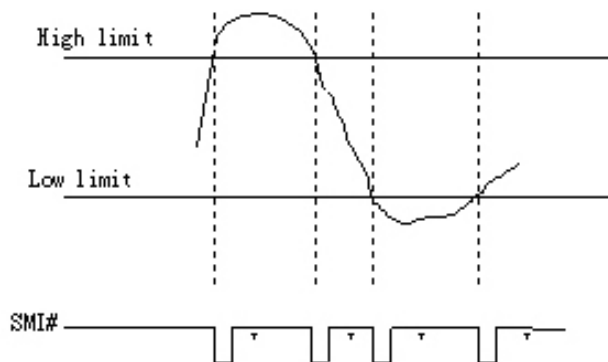

Figure 8.5

8.5 SMI# interrupt mode

8.5.1 Voltage SMI# mode :

SMI# interrupt for voltage is Two-Times Interrupt Mode. Voltage exceeding high limit or going below low limit will causes an interrupt if the previous interrupt has been reset by reading all the interrupt Status Register. (See Figure 8.6)



*Interrupt Reset when Interrupt Status Registers are read

Figure 8.6. SMI# Two-Times Interrupt Mode

8.5.2 Fan SMI# mode :

SMI# interrupt for fan is Two-Times Interrupt Mode. Fan count exceeding the limit, or exceeding and then going below the limit, will causes an interrupt if the previous interrupt has been reset by reading all the interrupt Status Register. (See Figure 8.7)

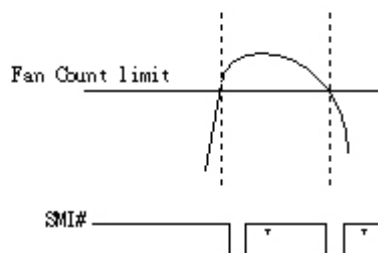

*Interrupt Reset when Interrupt Status Registers are read

Figure 8.7. Two-Times Interrupt Mode

8.5.3 Temperature 1 SMI# modes

The W83627HG temperature sensor 1 SMI# interrupt has two modes

(1) Comparator Interrupt Mode

Setting the T_{HYST} (Temperature Hysteresis) limit to 127°C will set temperature sensor 1 SMI# to the Comparator Interrupt Mode. Temperature exceeds T_O (Over Temperature) Limit causes an interrupt and this interrupt will be reset by reading all the Interrupt Status Register. Once an interrupt event has occurred by exceeding T_O , then reset, if the temperature remains above the T_O , the interrupt will occur again when the next conversion has completed. If an interrupt event has occurred by exceeding T_O and not reset, the interrupts will not occur again. The interrupts will continue to occur in this manner until the temperature goes below T_O . (See Figure 8.8)

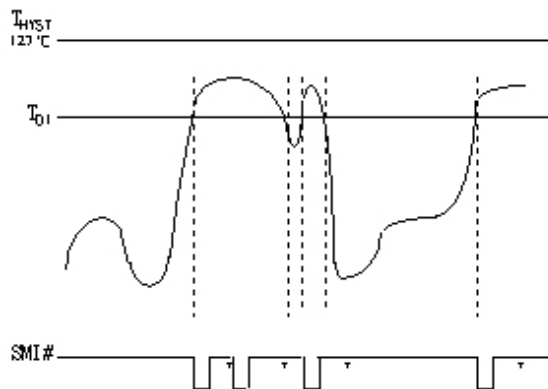

*Interrupt Reset when Interrupt Status Registers are read

Figure 8.8. Temperature 1 SMI# Comparator Interrupt Mode

(2) Two-Times Interrupt Mode

Setting the T_{HYST} lower than T_O will set temperature sensor 1 SMI# to the Two-Times Interrupt Mode. Temperature exceeding T_O causes an interrupt and then temperature going below T_{HYST} will also cause an interrupt if the previous interrupt has been reset by reading all the interrupt Status Register. Once an interrupt event has occurred by exceeding T_O , then reset, if the temperature remains above the T_{HYST} , the interrupt will not occur. (See Figure 8.9)

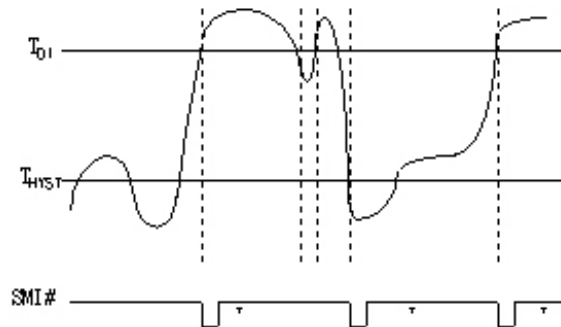

*Interrupt Reset when Interrupt Status Registers are read

Figure 8.9. Temperature 1 SMI# Two-Times Interrupt Mode

8.5.4 Temperature 2, 3 SMI# modes :

The W83627HG temperature sensor 2 and sensor 3 SMI# interrupt has two modes and it is programmed at CR[4Ch] bit 6.

(1) Comparator Interrupt Mode

Temperature exceeding T_O causes an interrupt and this interrupt will be reset by reading all the Interrupt Status Register. Once an interrupt event has occurred by exceeding T_O , then reset, if the temperature remains above the T_{HYST} , the interrupt will occur again when the next conversion has completed. If an interrupt event has occurred by exceeding T_O and not reset, the interrupts will not occur again. The interrupts will continue to occur in this manner until the temperature goes below T_{HYST} . (See Figure 8.10)

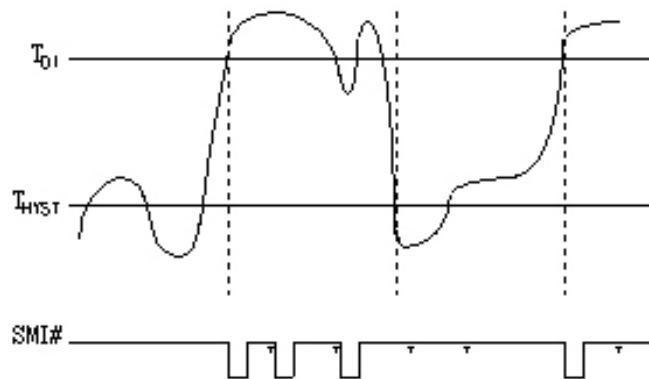

* Interrupt Reset when Interrupt Status Registers are read

Figure 8.10. Temperature 2, 3 SMI# Comparator Interrupt Mode

(2) Two-Times Interrupt Mode

Temperature exceeding T_O causes an interrupt and then temperature going below T_{HYST} will also cause an interrupt if the previous interrupt has been reset by reading all the interrupt Status Register. Once an interrupt event has occurred by exceeding T_O , then reset, if the temperature remains above the T_{HYST} , the interrupt will not occur. (See Figure 8.11)

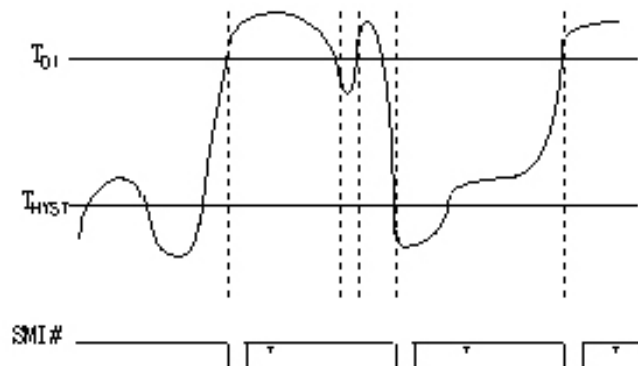

* Interrupt Reset when Interrupt Status Registers are read

Figure 8.11. Temperature 2, 3 SMI# Two-Times Interrupt Mode

8.6 OVT# interrupt mode

The W83627HG OVT# signal is only related to temperature sensor 2 and 3 (VTIN2 / VTIN3) . They have two modes :

(1) Comparator Mode :

Setting Bank1/2 CR[52h] bit 2 to 0 will set OVT# signal to comparator mode. Temperature exceeding T_O causes the OVT# output activated until the temperature is less than T_{HYST} . (See Figure 8.12)

(2) Interrupt Mode :

Setting Bank1/2 CR[52h] bit 2 to 1 will set OVT# signal to interrupt mode. Setting Temperature exceeding T_O causes the OVT# output activated indefinitely until reset by reading temperature sensor 2 or sensor 3 registers. Temperature exceeding T_O , then OVT# reset, and then temperature going below T_{HYST} will also cause the OVT# activated indefinitely until reset by reading temperature sensor2 or sensor 3 registers. Once the OVT# is activated by exceeding T_O , then reset, if the temperature remains above T_{HYST} , the OVT# will not be activated again. (See Figure 8.12)

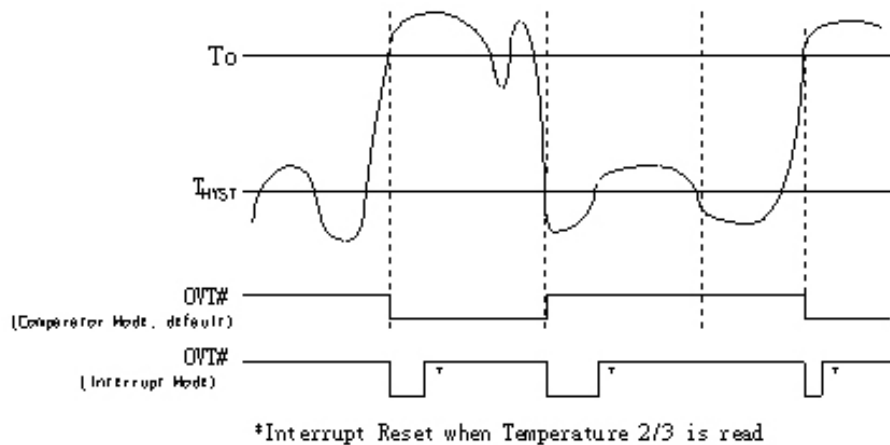
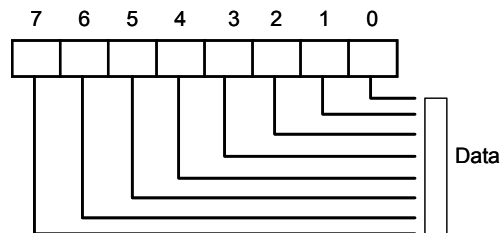

Figure 8.12. OVT# Interrupt Mode

8.7 REGISTERS AND RAM

Address Register (Port x5h)

Data Port : Port x5h
 Power on Default Value 00h
 Attribute : Bit 6 : 0 Read/write , Bit 7 : Read Only
 Size : 8 bits



Bit7 : Read Only

The logical 1 indicates the device is busy because of a Serial Bus transaction or another LPC bus transaction. With checking this bit, multiple LPC drivers can use W83627HG hardware monitor without interfering with each other or a Serial Bus driver.

It is the user's responsibility not to have a Serial Bus and LPC bus operations at the same time.

This bit is :

Set : with a write to Port x5h or when a Serial Bus transaction is in progress.

Reset : with a write or read from Port x6h if it is set by a write to Port x5h, or when the Serial Bus transaction is finished.

Bit 6-0 : Read/Write

Bit 7	Bit 6	Bit 5	Bit 4	Bit 3	Bit 2	Bit 1	Bit 0
Busy (Power On default 0)	Address Pointer (Power On default 00h)						
	A6	A5	A4	A3	A2	A1	A0



Address Pointer Index (A6-A0)

Registers and RAM	A6-A0 In Hex	Power On Value of Registers <k7 : 0> in Binary	Notes
Configuration Register	40h	00001000	
Interrupt Status Register 1	41h	00000000	Auto-increment to the address of Interrupt Status Register 2 after a read or write to Port x6h.
Interrupt Status Register 2	42h	00000000	
SMI#Y Mask Register 1	43h	00000000	Auto-increment to the address of SMIY Mask Register 2 after a read or write to Port x6h.
SMIY Mask Register 2	44h	00000000	
NMI Mask Register 1	45h	00000000	Auto-increment to the address of NMI Mask Register 2 after a read or write to Port x6h
NMI Mask Register 2	46h	01000000	
VID/Fan Divisor Register	47h	<7 : 4> = 0101; <3 : 0> = VID3-VID0	
Serial Bus Address Register	48h	<7> = 0 ; <6 : 0> = 0101101	
VID4 & Device ID Register	49h	<7 : 1> = 0000001; <0> = VID4	
Temperature 2 and Temperature 3 Serial Bus Address Register	4Ah	<7 : 0> = 00000001	
Pin Control Register	4Bh	<7 : 0> = 01000100	
IRQ/OVT# Property Select Register	4Ch	<7 : 0> = 00000000	
FAN IN/OUT and BEEP Control Register	4Dh	<7 : 0> = 00010101	
Register 50h-5Fh Bank Select Register	4Eh	<7> = 1 ; <6 : 3> = Reserved ; <2 : 0> = 000	

Address Pointer Index (A6-A0) , continued

Registers and RAM	A6-A0 In Hex	Power On Value of Registers <k7 : 0> in Binary	Notes
Winbond Vendor ID Register	4Fh	<7 : 0> = 01011100 (High Byte) <7 : 0> = 10100011 (LOW BYTE)	
POST RAM	00-1Fh		Auto-increment to the next location after a read or write to Port x6h and stop at 1Fh.
Value RAM	20-3Fh		
Value RAM	60-7Fh		Auto-increment to the next location after a read or write to Port x6h and stop at 7Fh.
Temperature 2 Registers	Bank1 50h-56h		
Temperature 3 Registers	Bank2 50h-56h		
Additional Configuration Registers	Bank4 50h-5Dh		

Data Register (Port x6h)

Data Port : Port x6h
 Power on Default Value : 00h
 Attribute : Read/write
 Size : 8 bits

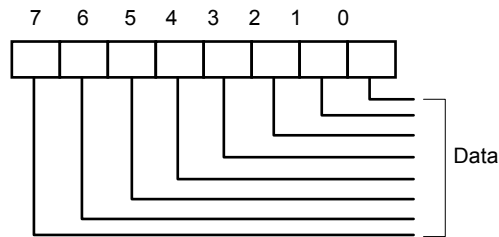

Bit 7-0 : Data to be read from or to be written to RAM and Register.

Configuration Register - Index 40h

Register Location : 40h
 Power on Default Value : 01h
 Attribute : Read/write
 Size : 8 bits

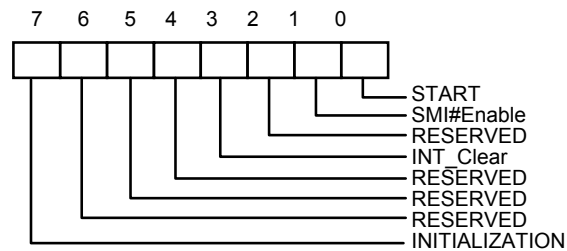

Bit 7 : A one restores power on default value to all registers except the Serial Bus Address register.
 This bit clears itself since the power on default is zero.

Bit 6 : Reserced

Bit 5 : Reserved

Bit 4 : Reserved

Bit 3 : A one disables the SMI# output without affecting the contents of Interrupt Status Registers.
 The device will stop monitoring. It will resume upon clearing of this bit.

Bit 2 : Reserved

Bit 1 : A one enables the SMI# Interrupt output.

Bit 0 : A one enables startup of monitoring operations, a zero puts the part in standby mode.

Note : The outputs of Interrupt pins will not be cleared if the user writes a zero to this location after an interrupt has occurred unlike "INT_Clear" bit.

Interrupt Status Register 1 - Index 41h

Register Location : 41h
 Power on Default Value : 00h
 Attribute : Read Only
 Size : 8 bits

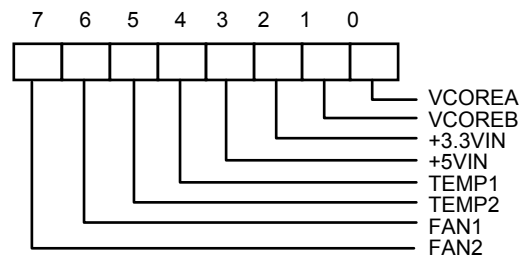

Bit 7 : A one indicates the fan count limit of FAN2 has been exceeded.

Bit 6 : A one indicates the fan count limit of FAN1 has been exceeded.

Bit 5 : A one indicates a High limit of VTIN2 has been exceeded from temperature sensor 2.

Bit 4 : A one indicates a High limit of VTIN1 has been exceeded from temperature sensor 1.

Bit 3 : A one indicates a High or Low limit of +5VIN has been exceeded.

Bit 2 : A one indicates a High or Low limit of +3.3VIN has been exceeded.

Bit 1 : A one indicates a High or Low limit of VCOREB has been exceeded.

Bit 0 : A one indicates a High or Low limit of VCOREA has been exceeded.

Interrupt Status Register 2 - Index 42h

Register Location : 42h
 Power on Default Value : 00h
 Attribute : Read Only
 Size : 8 bits

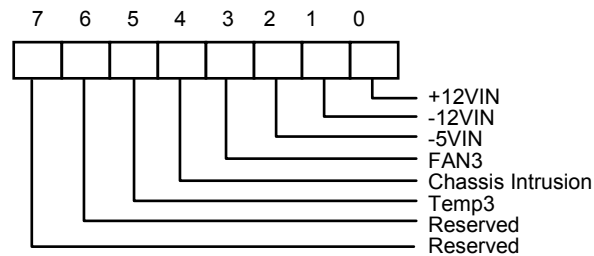

Bit 7-6 : Reserved. This bit should be set to 0.

Bit 5 : A "1" indicates a High limit of VTIN3 has been exceeded from temperature sensor 3.

Bit 4 : A "1" indicates Chassis Intrusion Event Occur. When CASEOPEN# (Pin 76) gone logic low, this bit will be set "1".

Bit 3 : A "1" indicates the fan count limit of FAN3 has been exceeded.

Bit 2 : A "1" indicates a High or Low limit of -5VIN has been exceeded.

Bit 1 : A "1" indicates a High or Low limit of -12VIN has been exceeded.

Bit 0 : A "1" indicates a High or Low limit of +12VIN has been exceeded.

SMI# Mask Register 1 - Index 43h

Register Location : 43h
 Power on Default Value : 00h
 Attribute : Read/Write
 Size : 8 bits

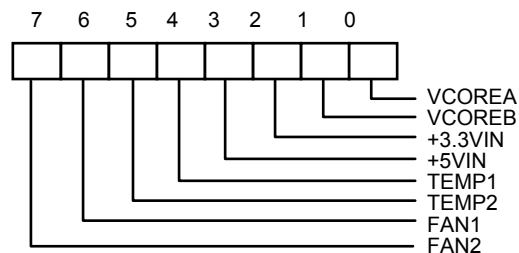

Bit 7-0 : A one disables the corresponding interrupt status bit for $\overline{\text{SMI}}$ interrupt.

SMI# Mask Register 2 - Index 44h

Register Location : 44h
 Power on Default Value : 00h
 Attribute : Read/Write
 Size : 8 bits

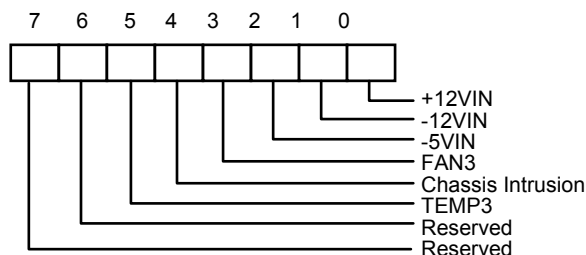

Bit 7-6 : Reserved. This bit should be set to 0.

Bit 5-0 : A one disables the corresponding interrupt status bit for $\overline{\text{SMI}}$ interrupt.

Reserved Register - Index 45h

This register is reserved.

Chassis Clear Register - Index 46h (Not available for A Version)

Register Location : 46h
 Power on Default Value : 00h
 Attribute : Read/Write
 Size : 8 bits

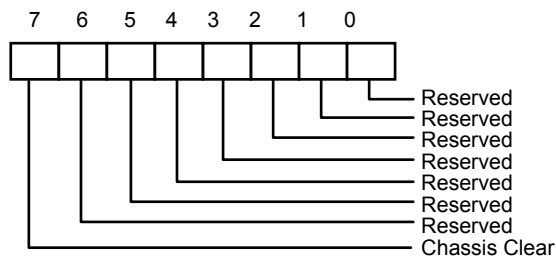

Bit 7 : **Clear Chassis Intrusion Event.** Write "1" will make Hardware Monitor Register Index 42, bit 4 cleared to "0" . This bit self clears after clearing Chassis Intrusion event. For W83627HG A Version, Clear Chassis Intrusion Event has been changed from this bit to LDA CRE6[6].

Bit 6-0 : Reserved, and should be set to 0.

VID/Fan Divisor Register - Index 47h

Register Location : 47h

Power on Default Value : <7 : 4> is 0101, <3 : 0> is mapped to VID<3 : 0>

Attribute : Read/Write

Size : 8 bits

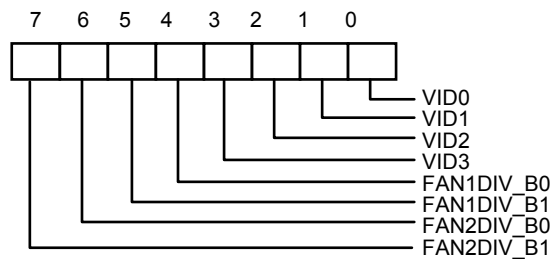

Bit 7-6 : FAN2 Speed Control.

Bit 5-4 : FAN1 Speed Control.

Bit 3-0 : The VID <3 : 0> inputs

Note : Please refer to Bank0 CR[5Dh] , Fan divisor table.

Serial Bus Address Register - Index 48h

Register Location : 48h

Power on Default Value : 2Dh

Size : 8 bits

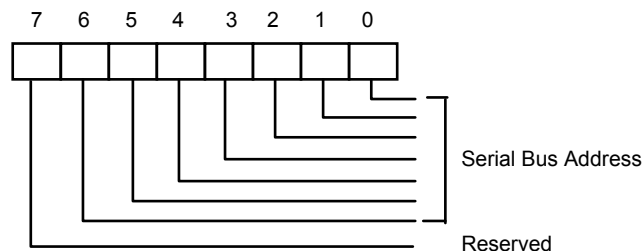

Bit 7 : Read Only - Reserved.

Bit 6-0 : Read/Write - Serial Bus address <6 : 0>.

Value RAM — Index 20h- 3Fh or 60h - 7Fh (auto-increment)

Address A6-A0	Address A6-A0 with Auto-Increment	Description
20h	60h	VCOREA reading
21h	61h	VCOREB reading
22h	62h	+3.3VIN reading
23h	63h	+5VIN reading
24h	64h	+12VIN reading
25h	65h	-12VIN reading
26h	66h	-5VIN reading
27h	67h	VTIN1 reading
28h	68h	FAN1 reading Note : This location stores the number of counts of the internal clock per revolution.
29h	69h	FAN2 reading Note : This location stores the number of counts of the internal clock per revolution.
2Ah	6Ah	FAN3 reading Note : This location stores the number of counts of the internal clock per revolution.
2Bh	6Bh	VCOREA High Limit, default value is defined by Vcore Voltage +0.2v.
2Ch	6Ch	VCOREA Low Limit, default value is defined by Vcore Voltage -0.2v.
2Dh	6Dh	VCOREB High Limit.
2Eh	6Eh	VCOREB Low Limit.
2Fh	6Fh	+3.3VIN High Limit
30h	70h	+3.3VIN Low Limit
31h	71h	+5VIN High Limit
32h	72h	+5VIN Low Limit
33h	73h	+12VIN High Limit
34h	74h	+12VIN Low Limit

Value RAM - Index 20h- 3Fh or 60h - 7Fh (auto-increment) , continued

Address A6-A0	Address A6-A0 with Auto-Increment	Description
35h	75h	-12VIN High Limit
36h	76h	-12VIN Low Limit
37h	77h	-5VIN High Limit
38h	78h	-5VIN Low Limit
39h	79h	Temperature sensor 1 (VTIN1) High Limit
3Ah	7Ah	Temperature sensor 1 (VTIN1) Hysteresis Limit
3Bh	7Bh	FAN1 Fan Count Limit Note : It is the number of counts of the internal clock for the Low Limit of the fan speed.
3Ch	7Ch	FAN2 Fan Count Limit Note : It is the number of counts of the internal clock for the Low Limit of the fan speed.
3Dh	7Dh	FAN3 Fan Count Limit Note : It is the number of counts of the internal clock for the Low Limit of the fan speed.
3E- 3Fh	7E- 7Fh	Reserved

Setting all ones to the high limits for voltages and fans (0111 1111 binary for temperature) means interrupts will never be generated except the case when voltages go below the low limits.

Voltage ID (VID4) & Device ID Register - Index 49h

Register Location : 49h

Power on Default Value : <7 : 1> is 000,0001 binary, <0> is mapped to VID <4>

Size : 8 bits

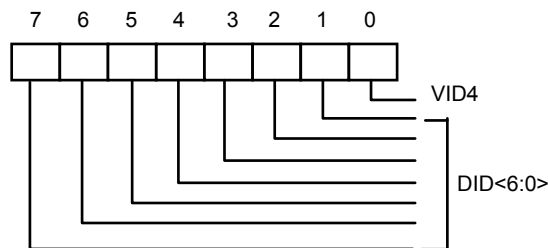

Bit 7-1 : Read Only - Device ID<6 : 0>

Bit 0 : Read/Write - The VID4 inputs.

Temperature 2 and Temperature 3 Serial Bus Address Register - Index 4Ah

Register Location : 4Ah
 Power on Default Value : 01h
 Attribute : Read/Write
 Size : 8 bits

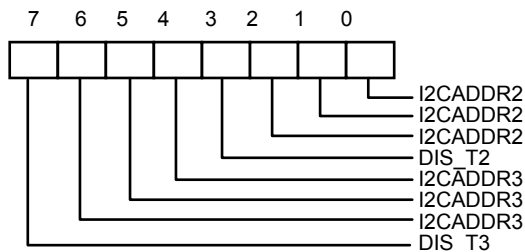

- Bit 7 : Set to 1, disable temperature sensor 3 and can not access any data from Temperature Sensor 3.
- Bit 6-4 : Temperature 3 Serial Bus Address. The serial bus address is 1001xxx. Where xxx are defined in these bits.
- Bit 3 : Set to 1, disable temperature Sensor 2 and can not access any data from Temperature Sensor 2.
- Bit 2-0 : Temperature 2 Serial Bus Address. The serial bus address is 1001xxx. Where xxx are defined in these bits.

Pin Control Register - Index 4Bh

Register Location : 4Bh
 Power on Default Value : 44h
 Attribute : Read/Write
 Size : 8 bits

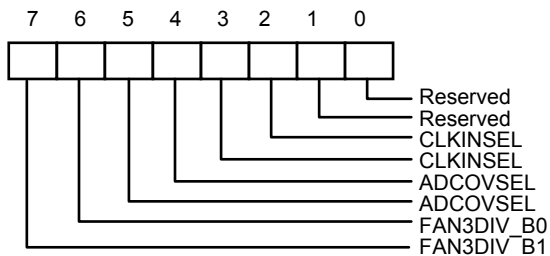

- Bit 7-6 : Fan3 speed divisor. Please refer to Bank0 CR[5Dh] , Fan divisor table.
- Bit 5-4 : Select A/D Converter Clock Input.
- <5 : 4> = 00 - default. ADC clock select 22.5 KHz.

- <5 : 4> = 01 - ADC clock select 5.6 Khz. (22.5K/4)
- <5 : 4> = 10 - ADC clock select 1.4Khz. (22.5K/16)
- <5 : 4> = 11 - ADC clock select 0.35 Khz. (22.5K/64)

Bit 3-2 : Clock Input Select.

- <3 : 2> = 00 - Pin 18 (CLKIN) select 14.318M Hz clock.
- <3 : 2> = 01 - Default. Pin 18 (CLKIN) select 24M Hz clock.
- <3 : 2> = 10 - Pin 18 (CLKIN) select 48M Hz clock .
- <3 : 2> = 11 - Reserved. Pin3 no clock input.

Bit 1-0 : Reserved. User defined.

IRQ/OVT# Property Select Register - Index 4Ch

Register Location : 4Ch
 Power on Default Value : 00h
 Attribute : Read/Write
 Size : 8 bits

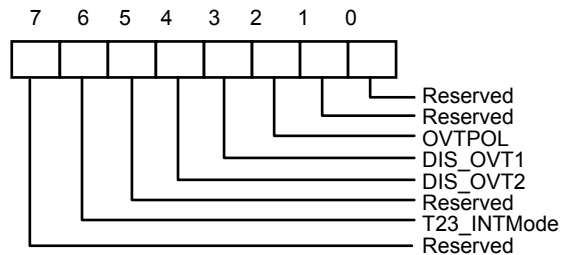

Bit 7 : Reserved. User Defined.

Bit 6 : Set to 1, the SMI# output type of Temperature 2 and 3 is set to Comparator Interrupt mode. Set to 0, the SMI# output type is set to Two-Times Interrupt mode. (default 0)

Bit 5 : Set to 1, the SMI# output type of Temperature 1 is set to Comparator Interrupt mode. Set to 0, the SMI# output type is set to Two-Times Interrupt mode. (default 0)

Bit 4 : Disable temperature sensor 3 over-temperature (OVT) output if set to 1. Default 0, enable OVT2 output through pin OVT#.

Bit 3 : Disable temperature sensor 2 over-temperature (OVT) output if set to 1. Default 0, enable OVT1 output through pin OVT#.

Bit 2 : Over-temperature polarity. Write 1, OVT# active high. Write 0, OVT# active low. Default 0.

Bit 1 : Reserved.

Bit 0 : Reserved.

FAN IN/OUT and BEEP Control Register- Index 4Dh

Register Location : 4Dh
 Power on Default Value : 15h
 Attribute : Read/Write
 Size : 8 bits

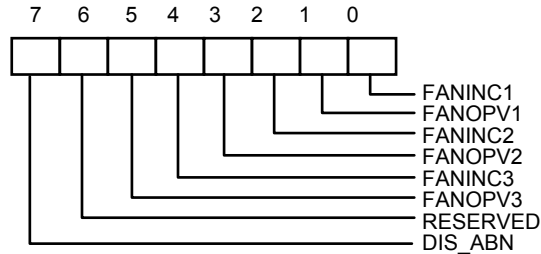

Bit 7 : Disable power-on abnormal the monitor voltage including V-Core A and +3.3V. If these voltage exceed the limit value, the pin (Open Drain) of BEEP will drives 600Hz and 120Hz frequency signal. Write 1, the frequency will be disabled. Default is 0. After power on, the system should set 1 to this bit to 1 in order to disable BEEP.

Bit 6 : Reserved.

Bit 5 : FAN 3 output value if FANINC3 sets to 0. Write 1, then pin 111 always generate logic high signal. Write 0, pin 111 always generates logic low signal. This bit default 0.

Bit 4 : FAN 3 Input Control. Set to 1, pin 111 acts as FAN clock input, which is default value. Set to 0, this pin 111 acts as FAN control signal and the output value of FAN control is set by this register bit 5.

Bit 3 : FAN 2 output value if FANINC2 sets to 0. Write 1, then pin 112 always generate logic high signal. Write 0, pin 112 always generates logic low signal. This bit default 0.

Bit 2 : FAN 2 Input Control. Set to 1, pin 112 acts as FAN clock input, which is default value. Set to 0, this pin 112 acts as FAN control signal and the output value of FAN control is set by this register bit 3.

Bit 1 : FAN 1 output value if FANINC1 sets to 0. Write 1, then pin 113 always generate logic high signal. Write 0, pin 113 always generates logic low signal. This bit default 0.

Bit 0 : FAN 1 Input Control. Set to 1, pin 113 acts as FAN clock input, which is default value. Set to 0, this pin 113 acts as FAN control signal and the output value of FAN control is set by this register bit 1.

Register 50h ~ 5Fh Bank Select Register - Index 4Eh (No Auto Increase)

Register Location : 4Eh
 Power on Default Value : 80h
 Attribute : Read/Write
 Size : 8 bits

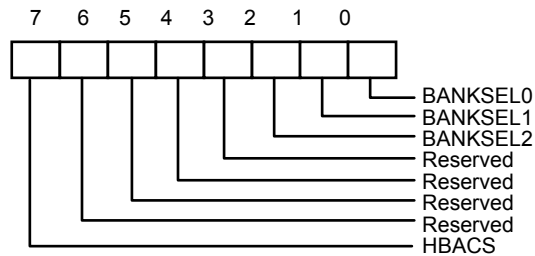

Bit 7 : HBACS- High byte access. Set to 1, access Register 4Fh high byte register. Set to 0, access Register 4Fh low byte register. Default 1.

Bit 6-3 : Reserved. This bit should be set to 0.

Bit 2-0 : Index ports 0x50~0x5F Bank select.

Winbond Vendor ID Register - Index 4Fh (No Auto Increase)

Register Location : 4Fh
 Power on Default Value : <15 : 0> = 5CA3h
 Attribute : Read Only
 Size : 16 bits

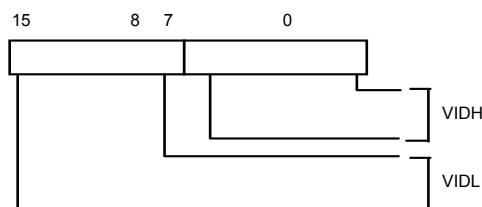

Bit 15-8 : Vendor ID High Byte if CR4E.bit7=1. Default 5Ch.

Bit 7-0 : Vendor ID Low Byte if CR4E.bit7=0. Default A3h.

Winbond Test Register - Index 50h ~ 55h (Bank 0)

These registers are reserved for Winbond internal use.

BEEP Control Register 1 - Index 56h (Bank 0)

Register Location : 56h
 Power on Default Value : 00h
 Attribute : Read/Write
 Size : 8 bits

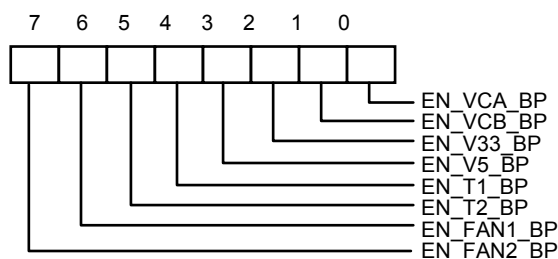

- Bit 7 : Enable BEEP Output from FAN 2 if the monitor value exceed the limit value. Write 1, enable BEEP output, which is default value.
- Bit 6 : Enable BEEP Output from FAN 1 if the monitor value exceed the limit value. Write 1, enable BEEP output, which is default value.
- Bit 5 : Enable BEEP Output from Temperature Sensor 2 if the monitor value exceed the limit value. Write 1, enable BEEP output. Default 0
- Bit 4 : Enable BEEP output for Temperature Sensor 1 if the monitor value exceed the limit value. Write 1, enable BEEP output. Default 0
- Bit 3 : Enable BEEP output from VDD (+5V) , Write 1, enable BEEP output if the monitor value exceed the limits value. Default is 0, which is disable BEEP output.
- Bit 2 : Enable BEEP output from +3.3V. Write 1, enable BEEP output, which is default value.
- Bit 1 : Enable BEEP output from VCOREB. Write 1, enable BEEP output, which is default value.
- Bit 0 : Enable BEEP Output from VCOREA if the monitor value exceed the limits value. Write 1, enable BEEP output, which is default value

BEEP Control Register 2 - Index 57h (Bank 0)

Register Location : 57h

Power on Default Value : 80h

Attribute : Read/Write

Size : 8 bits

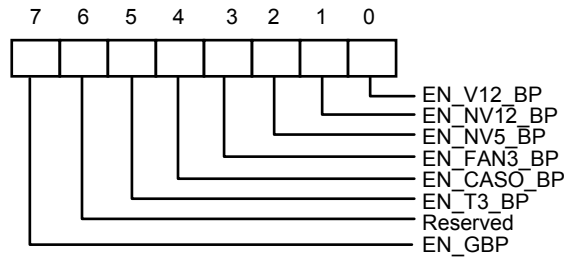

Bit 7 : Enable Global BEEP. Write 1, enable global BEEP output. Default 1. Write 0, disable all BEEP output.

Bit 6 : Reserved. This bit should be set to 0.

Bit 5 : Enable BEEP Output from Temperature Sensor 3 if the monitor value exceed the limit value. Write 1, enable BEEP output. Default 0

Bit 4 : Enable BEEP output for case open if the monitor value exceed the limit value. Write 1, enable BEEP output. Default is 0.

Bit 3 : Enable BEEP Output from FAN 3 if the monitor value exceed the limit value. Write 1, enable BEEP output. Default is 0.

Bit 2 : Enable BEEP output from -5V, Write 1, enable BEEP output if the monitor value exceed the limits value. Default is 0, which is disable BEEP output.

Bit 1 : Enable BEEP output from -12V, Write 1, enable BEEP output if the monitor value exceed the limits value. Default is 0, which is disable BEEP output.

Bit 0 : Enable BEEP output from +12V, Write 1, enable BEEP output if the monitor value exceed the limits value. Default is 0, which is disable BEEP output.

Chip ID Register - Index 58h (Bank 0)

Register Location : 58h
 Power on Default Value : 21h
 Attribute : Read Only
 Size : 8 bits

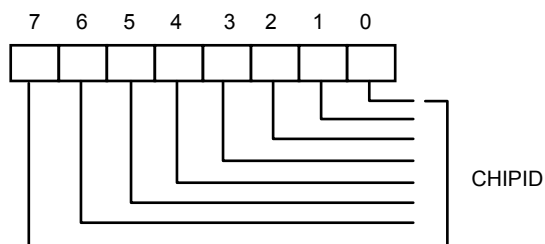

Bit 7 : Winbond Chip ID number. Read this register will return 21h.

Reserved Register - Index 59h (Bank 0)

Register Location : 59h
 Power on Default Value : 70h
 Attribute : Read/Write
 Size : 8 bits

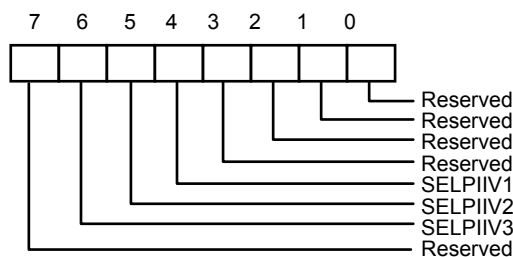

Bit 7 : Reserved

Bit 6 : Temperature sensor diode 3. Set to 1, select Pentium II compatible Diode. Set to 0 to select 2N3904 Bipolar mode.

Bit 5 : Temperature sensor diode 2. Set to 1, select Pentium II compatible Diode. Set to 0 to select 2N3904 Bipolar mode.

Bit 4 : Temperature sensor diode 1. Set to 1, select Pentium II compatible Diode. Set to 0 to select 2N3904 Bipolar mode.

Bit 3-0 : Reserved

PWMOUT1 Control Register - Index 5Ah (Bank 0)

Register Location : 5Ah
 Power on default value : FFh
 Attribute : Read/Write
 Size : 8 bits

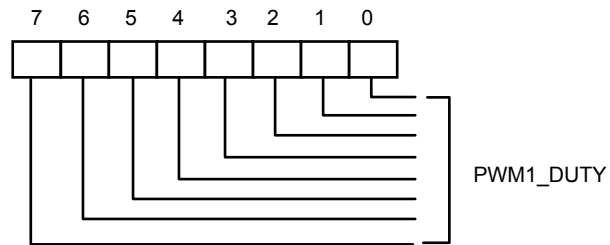

Bit 7 : PWMOUT1 duty cycle control
 Write FF, Duty cycle is 100%, Write 00, Duty cycle is 0%.

PWMOUT2 Control Register - Index 5Bh (Bank 0)

Register Location : 5Bh
 Power on default value : FFh
 Attribute : Read/Write
 Size : 8 bits

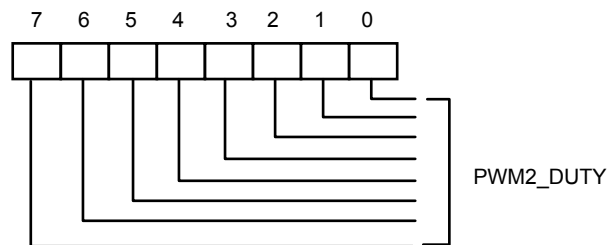

Bit 7 : PWMOUT2 duty cycle control. Write FF, Duty cycle is 100%, Write 00, Duty cycle is 0%.

PWMOUT1/2 Clock Select Register - Index 5Ch (Bank 0)

Register Location : 5Ch
 Power on Default Value : 11h
 Attribute : Read/Write
 Size : 8 bits

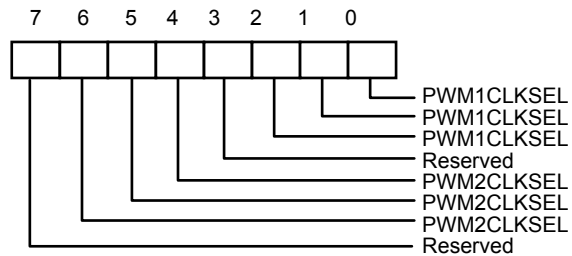

Bit 7 : Reserved

Bit 6-4 : PWMOUT2 clock selection. The clock defined frequency is same as PWMOUT1 clock selection.

Bit 3 : Reserved

Bit 2-0 : PWMOUT1 clock Selection.

- <2 : 0> = 000 : 46.87K Hz
- <2 : 0> = 001 : 23.43K Hz (Default)
- <2 : 0> = 010 : 11.72K Hz
- <2 : 0> = 011 : 5.85K Hz
- <2 : 0> = 100 : 2.93K Hz

VBAT Monitor Control Register - Index 5Dh (Bank 0)

Register Location : 5Dh
 Power on Default Value : 00h
 Attribute : Read/Write
 Size : 8 bits

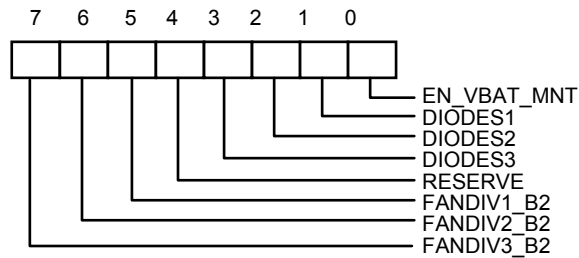

Bit 7 : Fan3 divisor Bit 2.

Bit 6 : Fan2 divisor Bit 2.

Bit 5 : Fan1 divisor Bit 2.

Bit 4 : Reserved.

Bit 3 : Temperature sensor 3 select into thermal diode such as Pentium II CPU supported. Set to 1, select bipolar sensor. Set to 0, select thermistor sensor.

Bit 2 : Sensor 2 type selection. Set to 1, select bipolar sensor. Set to 0, select thermistor sensor.

Bit 1 : Sensor 1 type selection. Set to 1, select bipolar sensor. Set to 0, select thermistor sensor.

Bit 0 : Set to 1, enable battery voltage monitor. Set to 0, disable battery voltage monitor. If enable this bit, the monitor value is value after one monitor cycle. Note that the monitor cycle time is at least 300ms for W83627HG hardware monitor.

Fan divisor table :

Bit 2	Bit 1	Bit 0	Fan Divisor	Bit 2	Bit 1	Bit 0	Fan Divisor
0	0	0	1	1	0	0	16
0	0	1	2	1	0	1	32
0	1	0	4	1	1	0	64
0	1	1	8	1	1	1	128

Reserved Register - Index 5Eh (Bank 0)

This register is reserved.

Reserved Register - Index 5Fh (Bank 0)

This register is reserved.

VTIN2 Reading (High Byte) - Index 50h (Bank 1)

Register Location : 50h

Attribute : Read Only

Size : 8 bits

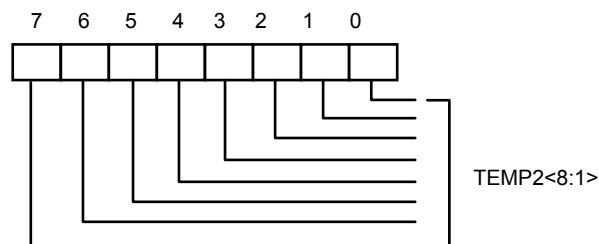

Bit 7 : Temperature <8 : 1> of sensor 2, which is high byte.

VTIN2 Reading (Low Byte) - Index 51h (Bank 1)

Register Location : 51h

Attribute : Read Only

Size : 8 bits

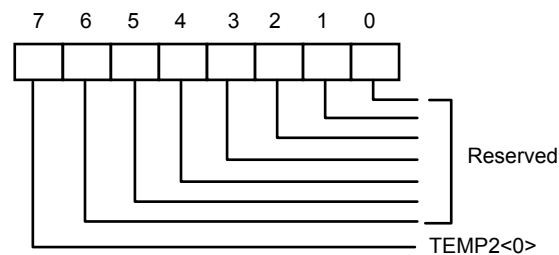

Bit 7 : Temperature <0> of sensor2, which is low byte.

Bit 6-0 : Reserved.

VTIN2 Configuration Register - Index 52h (Bank 1)

Register Location : 52h

Power on Default Value 00h
 Size : 8 bits

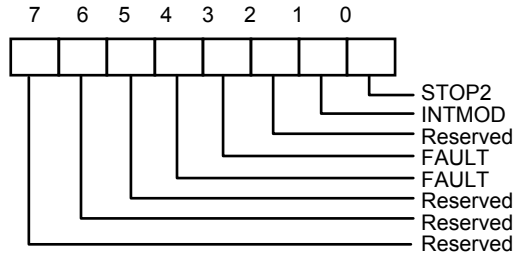

- Bit 7-5 : Read - Reserved. This bit should be set to 0.
- Bit 4-3 : Read/Write - Number of faults to detect before setting OVT# output to avoid false tripping due to noise.
- Bit 2 : Read - Reserved. This bit should be set to 0.
- Bit 1 : Read/Write - OVT# Interrupt mode select. This bit default is set to 0, which is compared mode. When set to 1, interrupt mode will be selected.
- Bit 0 : Read/Write - When set to 1 the sensor will stop monitor.

VTIN2 Hysteresis (High Byte) Register - Index 53h (Bank 1)

Register Location : 53h
 Power on Default Value 4Bh
 Attribute : Read/Write
 Size : 8 bits

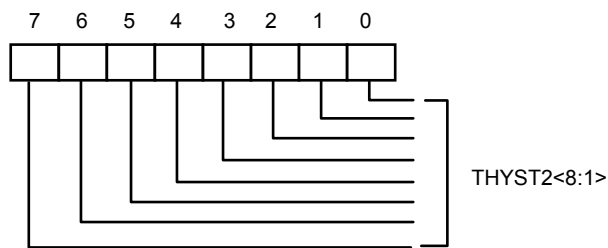

Bit 7-0 : Temperature hysteresis bit 8-1, which is High Byte. The temperature default 75 degree C.

VTIN2 Hysteresis (Low Byte) Register - Index 54h (Bank 1)

Register Location : 54h
 Power on Default Value 00h
 Attribute : Read/Write
 Size : 8 bits

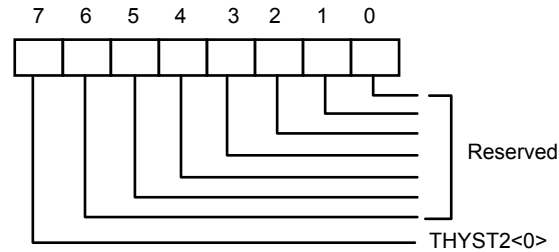

Bit 7 : Hysteresis temperature bit 0, which is low Byte.

Bit 6-0 : Reserved.

VTIN2 Over-temperature (High Byte) Register - Index 55h (Bank 1)

Register Location : 55h
 Power on Default Value 50h
 Attribute : Read/Write
 Size : 8 bits

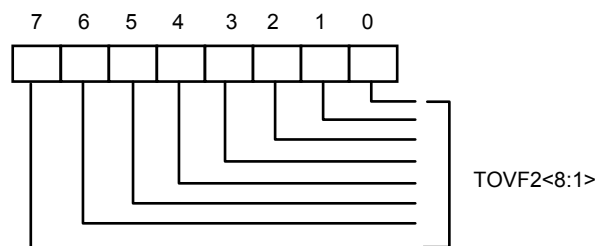

Bit 7-0 : Over-temperature bit 8-1, which is High Byte. The temperature default 80 degree C.

VTIN2 Over-temperature (Low Byte) Register - Index 56h (Bank 1)

Register Location : 56h
 Power on Default Value 00h
 Attribute : Read/Write
 Size : 8 bits

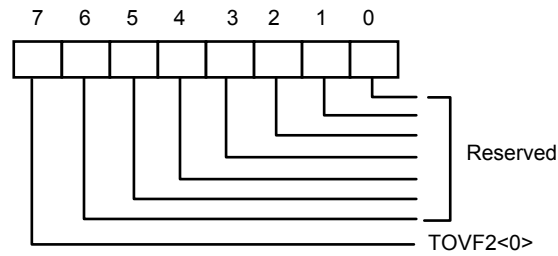

Bit 7 : Over-temperature bit 0, which is low Byte.

Bit 6-0 : Reserved.

VTIN3 Reading (High Byte) Register - Index 50h (Bank 2)

Register Location : 50h
 Attribute : Read Only
 Size : 8 bits

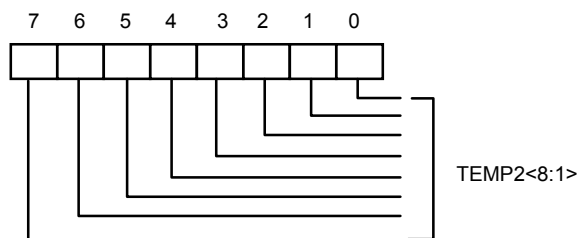

Bit 7-0 : Temperature <8 : 1> of sensor 2, which is high byte.

VTIN3 Reading (Low Byte) Register - Index 51h (Bank 2)

Register Location : 51h
 Attribute : Read Only
 Size : 8 bits

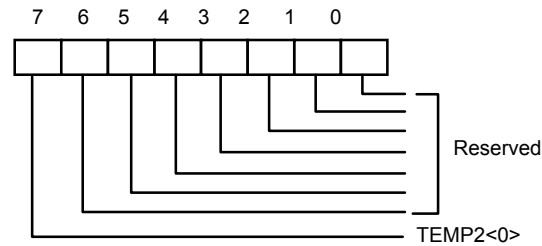

Bit 7 : Temperature <0> of sensor2, which is low byte.

Bit 6-0 : Reserved.

VTIN3 Configuration Register - Index 52h (Bank 2)

Register Location : 52h
 Power on Default Value : 00h
 Attribute : Read/Write
 Size : 8 bits

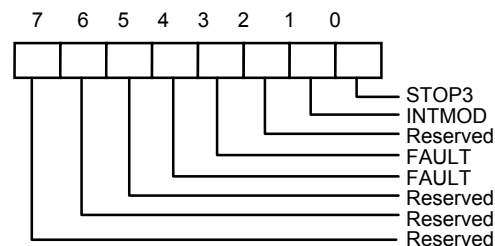

Bit 7-5 : Read - Reserved. This bit should be set to 0.

Bit 4-3 : Read/Write - Number of faults to detect before setting OVT# output to avoid false tripping due to noise.

Bit 2 : Read - Reserved. This bit should be set to 0.

Bit 1 : Read/Write - OVT# Interrupt Mode select. This bit default is set to 0, which is Compared Mode. When set to 1, Interrupt Mode will be selected.

Bit 0 : Read/Write - When set to 1 the sensor will stop monitor.

VTIN3 Hysteresis (High Byte) Register - Index 53h (Bank 2)

Register Location : 53h
 Power on Default Value : 4Bh
 Attribute : Read/Write
 Size : 8 bits

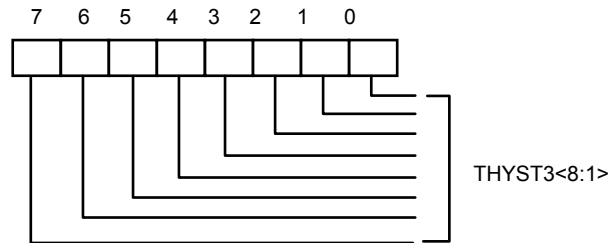

Bit 7-0 : Temperature hysteresis bit 8-1, which is High Byte. The temperature default 75 degree C.

VTIN3 Hysteresis (Low Byte) Register - Index 54h (Bank 2)

Register Location : 54h
 Power on Default Value : 00h
 Attribute : Read/Write
 Size : 8 bits

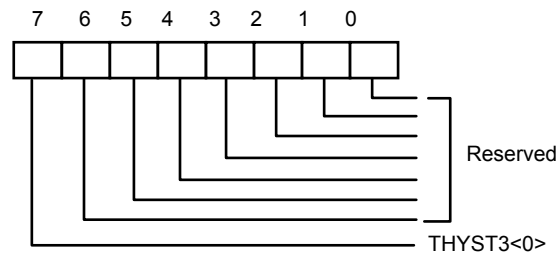

Bit 7 : Hysteresis temperature bit 0, which is low Byte.

Bit 6-0 : Reserved.

VTIN3 Over-temperature (High Byte) Register - Index 55h (Bank 2)

Register Location : 55h
 Power on Default Value : 50h
 Attribute : Read/Write
 Size : 8 bits

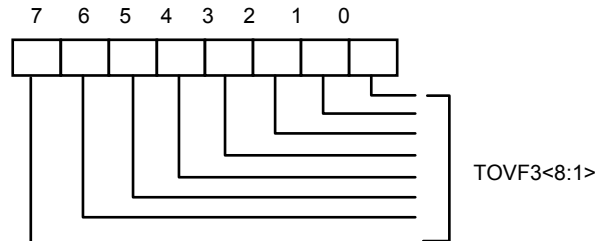

Bit 7-0 : Over-temperature bit 8-1, which is High Byte. The temperature default 80 degree C.

VTIN3 Over-temperature (Low Byte) Register - Index 56h (Bank 2)

Register Location : 56h
 Power on Default Value : 00h
 Attribute : Read/Write
 Size : 8 bits

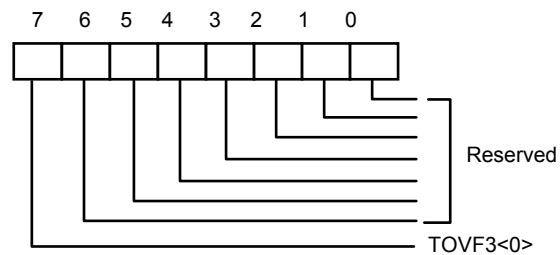

Bit 7 : Over-temperature bit 0, which is low Byte.

Bit 6-0 : Reserved.

Interrupt Status Register 3 - Index 50h (BANK4)

Register Location : 50h
 Power on Default Value : 00h
 Attribute : Read Only
 Size : 8 bits

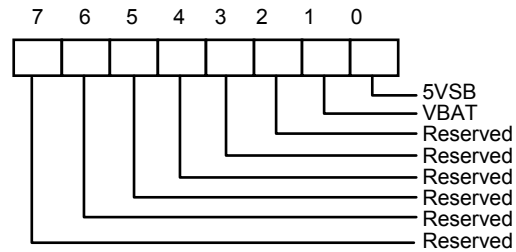

Bit 7-2 : Reserved.

Bit 1 : A one indicates a High or Low limit of VBAT has been exceeded.

Bit 0 : A one indicates a High or Low limit of 5VSB has been exceeded.

SMI# Mask Register 3 - Index 51h (BANK 4)

Register Location : 51h
 Power on Default Value : 00h
 Attribute : Read/Write
 Size : 8 bits

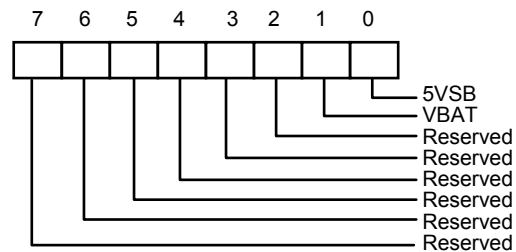

Bit 7-2 : Reserved.

Bit 1 : A one disables the corresponding interrupt status bit for $\overline{\text{SMI}}$ interrupt.

Bit 0 : A one disables the corresponding interrupt status bit for $\overline{\text{SMI}}$ interrupt.

Reserved Register - Index 52h (Bank 4)

This register is reserved for Winbond internal use.

BEEP Control Register 3 - Index 53h (Bank 4)

Register Location : 53h
 Power on Default Value : 00h
 Attribute : Read/Write
 Size : 8 bits

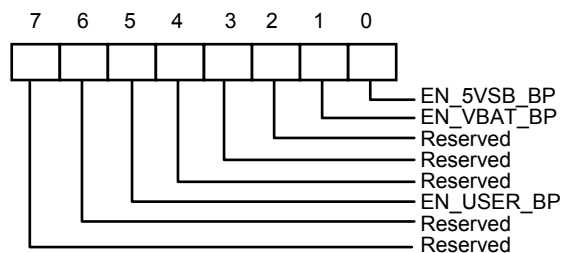

Bit 7-6 : Reserved.

Bit 5 : User define BEEP output function. Write 1, the BEEP is always active. Write 0, this function is inactive. (Default 0)

Bit 4-2 : Reserved.

Bit 1 : Enable BEEP output from VBAT. Write 1, enable BEEP output, which is default value.

Bit 0 : Enable BEEP Output from 5VSB. Write 1, enable BEEP output, which is default value.

Temperature Sensor 1 Offset Register - Index 54h (*Bank 4*)

Register Location : 54h
 Power on Default Value : 00h
 Attribute : Read/Write
 Size : 8 bits

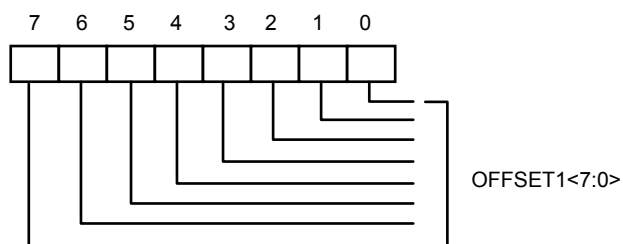

Bit 7-0 : Temperature 1 base temperature. The temperature is added by both monitor value and offset value.

Temperature Sensor 2 Offset Register - Index 55h (Bank 4)

Register Location : 55h
 Power on Default Value : 00h
 Attribute : Read/Write
 Size : 8 bits

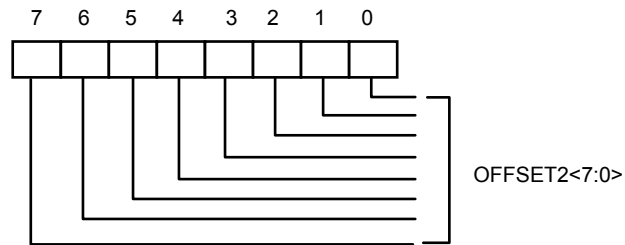

Bit 7-0 : Temperature 2 base temperature. The temperature is added by both monitor value and offset value.

Temperature Sensor 3 Offset Register - Index 56h (Bank 4)

Register Location : 56h
 Power on Default Value : 00h
 Attribute : Read/Write
 Size : 8 bits

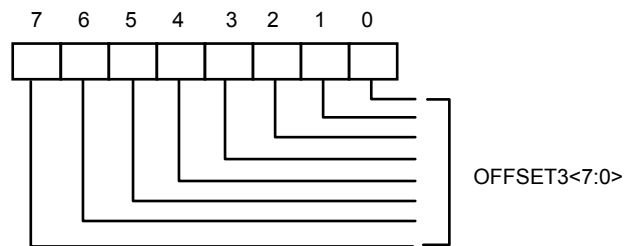

Bit 7-0 : Temperature 3 base temperature. The temperature is added by both monitor value and offset value.

Reserved Register - Index 57h ~ 58h

These registers are reserved for Winbond internal use.

Real Time Hardware Status Register I - Index 59h (Bank 4)

Register Location : 59h
 Power on Default Value : 00h
 Attribute : Read Only
 Size : 8 bits

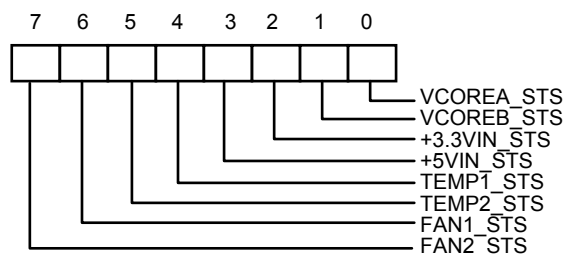

- Bit 7 : FAN 2 Status. Set 1, the fan speed counter is over the limit value. Set 0, the fan speed counter is in the limit range.
- Bit 6 : FAN 1 Status. Set 1, the fan speed counter is over the limit value. Set 0, the fan speed counter is in the limit range.
- Bit 5 : Temperature sensor 2 Status. Set 1, the voltage of temperature sensor is over the limit value. Set 0, the voltage of temperature sensor is in the limit range.
- Bit 4 : Temperature sensor 1 Status. Set 1, the voltage of temperature sensor is over the limit value. Set 0, the voltage of temperature sensor is in the limit range.
- Bit 3 : +5V Voltage Status. Set 1, the voltage of +5V is over the limit value. Set 0, the voltage of +5V is in the limit range.
- Bit 2 : +3.3V Voltage Status. Set 1, the voltage of +3.3V is over the limit value. Set 0, the voltage of +3.3V is in the limit range.
- Bit 1 : VCOREB Voltage Status. Set 1, the voltage of VCOREB is over the limit value. Set 0, the voltage of VCOREB is in the limit range.
- Bit 0 : VCOREA Voltage Status. Set 1, the voltage of VCORE A is over the limit value. Set 0, the voltage of VCORE A is in the limit range.

Real Time Hardware Status Register II - Index 5Ah (Bank 4)

Register Location : 5Ah
 Power on Default Value : 00h
 Attribute : Read Only
 Size : 8 bits

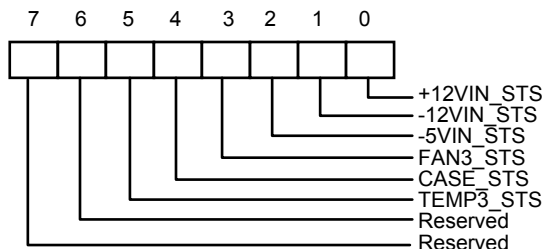

Bit 7-6 : Reserved

Bit 5 : Temperature sensor 3 Status. Set 1, the voltage of temperature sensor is over the limit value. Set 0, the voltage of temperature sensor is in the limit range.

Bit 4 : Case Open Status. Acts like Index 42[4], when Chassis Intrusion Event occurs, this bit will be set 1. Until the event is cleared, this bit returns to 0.

Bit 3 : FAN3 Voltage Status. Set 1, the fan speed counter is over the limit value. Set 0, the fan speed counter is during the limit range.

Bit 2 : -5V Voltage Status. Set 1, the voltage of -5V is over the limit value. Set 0, the voltage of -5V is during the limit range.

Bit 1 : -12V Voltage Status. Set 1, the voltage of -12V is over the limit value. Set 0, the voltage of -12V is during the limit range.

Bit 0 : +12V Voltage Status. Set 1, the voltage of +12V is over the limit value. Set 0, the voltage of +12V is in the limit range.

Real Time Hardware Status Register III - Index 5Bh (Bank 4)

Register Location : 5Bh
 Power on Default Value : 00h
 Attribute : Read Only
 Size : 8 bits

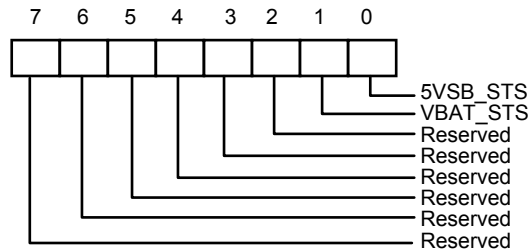

Bit 7-2 : Reserved.

Bit 1 : VBAT Voltage Status. Set 1, the voltage of VBAT is over the limit value. Set 0, the voltage of VBAT is during the limit range.

Bit 0 : 5VSB Voltage Status. Set 1, the voltage of 5VSB is over the limit value. Set 0, the voltage of 5VSB is in the limit range.

Reserved Register - Index 5Ch (*Bank 4*)

This register is reserved for Winbond internal use.

VID Output Register - Index 5Dh (*Bank 4*)

Register Location : 5Dh

Power on Default Value : <7 : 0> = 0000,0000h

Attribute : Read/Write

Size : 8 bits

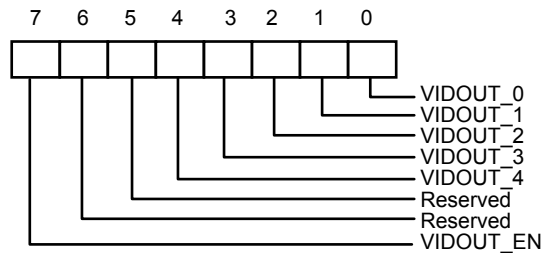

Bit 7 : VID Output Enable. Set 1, enable VID pins to output. Set 0, disable VID pins to output. Default is 0.

Bit 6-5 : Reserved.

Bit 4-0 : Set 1, VID pins drive a 1 . Set 0, VID pins drive a 0. Default is 0.

Value RAM 2— Index 50h - 5Ah (auto-increment) (BANK 5)

Address A6-A0 Auto-Increment	Description
50h	5VSB reading
51h	VBAT reading
52h	Reserved
53h	Reserved
54h	5VSB High Limit
55h	5VSB Low Limit.
56h	VBAT High Limit
57h	VBAT Low Limit

Winbond Test Register - Index 50h (Bank 6)

This register is reserved for Winbond internal use.

9. SERIAL IRQ

W83627HG supports a serial IRQ scheme. This allows a signal line to be used to report the legacy ISA interrupt requests. Because more than one device may need to share the signal serial IRQ signal line, an open drain signal scheme is used. The clock source is the PCI clock. The serial interrupt is transferred on the IRQSER signal, one cycle consisting of three frames types: a start frame, several IRQ/Data frame, and one Stop frame.

9.1 Start Frame

There are two modes of operation for the IRQSER Start frame : Quiet mode and Continuous mode.

In the Quiet mode, the peripheral drives the SERIRQ signal active low for one clock, and then tri-states it. This brings all the states machines of the peripherals from idle to active states. The host controller will then take over driving IRQSER signal low in the next clock and will continue driving the IRQSER low for programmable 3 to 7 clock periods. This makes the total number of clocks low for 4 to 8 clock periods. After these clocks, the host controller will drive the IRQSER high for one clock and then tri-states it.

In the Continuous mode, only the host controller initiates the START frame to update IRQ/Data line information. The host controller drives the IRQSER signal low for 4 to 8 clock periods. Upon a reset, the IRQSER signal is defaulted to the Continuous mode for the host controller to initiate the first Start frame.

9.2 IRQ/Data Frame

Once the start frame has been initiated, all the peripherals must start counting frames based on the rising edge of the start pulse. Each IRQ/Data Frame is three clocks: Sample phase, Recovery phase, and Turn-around phase.

During the Sample phase, the peripheral drives SERIRQ low if the corresponding IRQ is active. If the corresponding IRQ is inactive, then IRQSER must be left tri-stated. During the Recovery phase, the peripheral device drives the IRQSER high. During the Turn-around phase, the peripheral device left the IRQSER tri-stated.

The IRQ/Data Frame has a number of specific order, as shown in Table 9-1.

Table 9-1 IRQSER Sampling periods

IRQ/Data Frame	Signal Sampled	# of clocks past Start
1	IRQ0	2
2	IRQ1	5
3	$\overline{\text{SMI}}$	8
4	IRQ3	11
5	IRQ4	14
6	IRQ5	17
7	IRQ6	20
8	IRQ7	23
9	IRQ8	26
10	IRQ9	29
11	IRQ10	32
12	IRQ11	35
13	IRQ12	38
14	IRQ13	41
15	IRQ14	44
16	IRQ15	47
17	$\overline{\text{IOCHCK}}$	50
18	$\overline{\text{INTA}}$	53
19	$\overline{\text{INTB}}$	56
20	$\overline{\text{INTC}}$	59
21	$\overline{\text{INTD}}$	62
32 : 22	Unassigned	95

9.3 Stop Frame

After all IRQ/Data Frames have completed, the host controller will terminate IRQSER by a Stop frame. Only the host controller can initiate the Stop frame by driving IRQSER low for 2 or 3 clocks. If the Stop Frame is low for 2 clocks, the next IRQSER cycle's Sample mode is the Quiet mode. If the Stop Frame is low for 3 clocks, the next IRQSER cycle's Sample mode is the Continuous mode.

10. UART PORT

10.1 Universal Asynchronous Receiver/Transmitter (UART A, UART B)

The UARTs are used to convert parallel data into serial format for transmission and to convert serial data into parallel format during reception. The serial data format is a start bit, followed by five to eight data bits, a parity bit (if programmed) and one, one-and-a-half (five-bit format only) or two stop bits. The UARTs are capable of handling divisors of 1 to 65535 and producing a 16x clock for driving the internal transmitter logic. Provisions are also included to use this 16x clock to drive the receiver logic. The UARTs also support the MIDI data rate. Furthermore, the UARTs also include a complete modem control capability and 16-byte FIFOs for reception and transmission to reduce the number of interrupts presented to the CPU.

10.2 Register Description

10.2.1 UART Control Register (UCR) (Read/Write)

The UART Control Register defines and controls the protocol for asynchronous data communication, including data length, stop bit, parity, and baud rate selection.

BIT	7	6	5	4	3	2	1	0
NAME	BDLAB	SSE	PBFE	EPE	PBE	MSBE	DLS1	DLS0
DEFAULT	0	0	0	0	0	0	0	0

BIT	DESCRIPTION
7	BDLAB. Baudrate Divisor Latch Access Bit. When this bit is set to logical 1, designers can access the divisor (in 16-bit binary format) from the divisor latches of the baud-rate generator during a read or write operation. When this bit is set to logical 0, the Receiver Buffer Register, the Transmitter Buffer Register, and the Interrupt Control Register can be accessed.
6	SSE. Set Silence Enable. A logical 1 forces the Serial Output (SOUT) to a silent state (a logical 0). Only IRTX is affected by this bit; the transmitter is not affected.
5	PBFE. Parity Bit Fixed Enable. When PBE and PBFE of UCR are both set to logical 1, (1) If EPE is logical 1, the parity bit is fixed at logical 0 when transmitting and checking. (2) If EPE is logical 0, the parity bit is fixed at logical 1 when transmitting and checking.
4	EPE. Even Parity Enable. When PBE is set to logical 1, this bit counts the number of logical 1's in the data word bits and determines the parity bit. When this bit is set to logical 1, the parity bit is set to logical 1 if an even number of logical 1's are sent or checked. When the bit is set to logical 0, the parity bit is logical 1 if an odd number of logic 1's are sent or checked.
3	PBE. Parity Bit Enable. When this bit is set to logical 1, the transmitter inserts a stop bit between the last data bit and the stop bit of the SOUT, and the receiver checks the parity bit in the same position.
2	MSBE. Multiple Stop Bits Enable. This bit defines the number of stop bits in each serial character that is transmitted or received.

BIT	DESCRIPTION	
	(1) If MSBE is set to logical 0, one stop bit is sent and checked. (2) If MSBE is set to logical 1 and the data length is 5 bits, one-and-a-half stop bits are sent and checked. (3) If MSBE is set to logical 1 and the data length is 6, 7 or 8 bits, two stop bits are sent and checked.	
1	DLS1. Data Length Select Bit 1.	These two bits define the number of data bits that are sent or checked in each serial character.
0	DLS0. Data Length Select Bit 0.	

DLS1	DLS0	DATA LENGTH
0	0	5 bits
0	1	6 bits
1	0	7 bits
1	1	8 bits

The following table identifies the remaining UART registers. Each one is described separately in the following sections.

		Bit Number								
Register Address Base			0	1	2	3	4	5	6	7
+ 0 BDLAB = 0	Receiver Buffer Register (Read Only)	RBR	RX Data Bit 0	RX Data Bit 1	RX Data Bit 2	RX Data Bit 3	RX Data Bit 4	RX Data Bit 5	RX Data Bit 6	RX Data Bit 7
+ 0 BDLAB = 0	Transmitter Buffer Register (Write Only)	TBR	TX Data Bit 0	TX Data Bit 1	TX Data Bit 2	TX Data Bit 3	TX Data Bit 4	TX Data Bit 5	TX Data Bit 6	TX Data Bit 7
+ 1 BDLAB = 0	Interrupt Control Register	ICR	RBR Data Ready Interrupt Enable (ERDRI)	TBR Empty Interrupt Enable (ETBREI)	USR Interrupt Enable (EUSRI)	HSR Interrupt Enable (EHSRI)	0	0	0	0
+ 2	Interrupt Status Register (Read Only)	ISR	"0" if Interrupt Pending	Interrupt Status Bit (0)	Interrupt Status Bit (1)	Interrupt Status Bit (2)**	0	0	FIFOs Enabled **	FIFOs Enabled **
+ 2	UART FIFO Control Register (Write Only)	UFR	FIFO Enable	RCVR FIFO Reset	XMIT FIFO Reset	DMA Mode Select	Reserved	Reversed	RX Interrupt Active Level (LSB)	RX Interrupt Active Level (MSB)
+ 3	UART Control Register	UCR	Data Length Select Bit 0 (DLS0)	Data Length Select Bit 1 (DLS1)	Multiple Stop Bits Enable (MSBE)	Parity Bit Enable (PBE)	Even Parity Enable (EPE)	Parity Bit Fixed Enable (PBFE)	Set Silence Enable (SSE)	Baudrate Divisor Latch Access Bit (BDLAB)
+ 4	Handshake Control Register	HCR	Data Terminal Ready (DTR)	Request to Send (RTS)	Loopback RI Input	IRQ Enable	Internal Loopback Enable	0	0	0
+ 5	UART Status Register	USR	RBR Data Ready (RDR)	Overrun Error (OER)	Parity Bit Error (PBER)	No Stop Bit Error (NSER)	Silent Byte Detected (SBD)	TBR Empty (TBRE)	TSR Empty (TSRE)	RX FIFO Error Indication (RFEI) **
+ 6	Handshake Status Register	HSR	CTS Toggling (TCTS)	DSR Toggling (TDSR)	RI Falling Edge (FERI)	DCD Toggling (TDCD)	Clear to Send (CTS)	Data Set Ready (DSR)	Ring Indicator (RI)	Data Carrier Detect (DCD)
+ 7	User Defined Register	UDR	Bit 0	Bit 1	Bit 2	Bit 3	Bit 4	Bit 5	Bit 6	Bit 7
+ 0 BDLAB = 1	Baudrate Divisor Latch Low	BLL	Bit 0	Bit 1	Bit 2	Bit 3	Bit 4	Bit 5	Bit 6	Bit 7
+ 1 BDLAB = 1	Baudrate Divisor Latch High	BHL	Bit 8	Bit 9	Bit 10	Bit 11	Bit 12	Bit 13	Bit 14	Bit 15

*: Bit 0 is the least significant bit. The least significant bit is the first bit serially transmitted or received.

** : These bits are always 0 in 16450 Mode.

10.2.2 UART Status Register (USR) (Read/Write)

This 8-bit register provides information about the status of data transfer during communication.

BIT	7	6	5	4	3	2	1	0
NAME	RFEI	TSRE	TBRE	SBD	NSER	PBER	OER	RDR
DEFAULT	0	1	1	0	0	0	0	0

BIT	DESCRIPTION
7	RFEI. RX FIFO Error Indication. In 16450 mode, this bit is always set to logical 0. In 16550 mode, this bit is set to logical 1 when there is at least one parity-bit error and no stop-bit error or silent-byte detected in the FIFO. In 16550 mode, this bit is cleared to logical 0 by reading from the USR if there are no remaining errors left in the FIFO.
6	TSRE. Transmitter Shift Register Empty. In 16450 mode, this bit is set to logical 1 when TBR and TSR are both empty. In 16550 mode, it is set to logical 1 when the transmit FIFO and TSR are both empty. Otherwise, this bit is set to logical 0.
5	TBRE. Transmitter Buffer Register Empty. In 16450 mode, when a data character is transferred from TBR to TSR, this bit is set to logical 1. If ETREI or ICR is high, an interrupt is generated to notify the CPU to write the next data. In 16550 mode, this bit is set to logical 1 when the transmit FIFO is empty. It is set to logical 0 when the CPU writes data into TBR or the FIFO.
4	SBD. Silent Byte Detected. This bit is set to logical 1 to indicate that received data are kept in silent state for the time it takes to receive a full word, which includes the start bit, data bits, parity bit, and stop bits. In 16550 mode, it indicates the same condition for the data on the top of the FIFO. When the CPU reads USR, it sets this bit to logical 0.
3	NSER. No Stop Bit Error. This bit is set to logical 1 to indicate that the received data have no stop bit. In 16550 mode, it indicates the same condition for the data on the top of the FIFO. When the CPU reads USR, it sets this bit to logical 0.
2	PBER. Parity Bit Error. This bit is set to logical 1 to indicate that the received data has the wrong parity bit. In 16550 mode, it indicates the same condition for the data on the top of the FIFO. When the CPU reads USR, it sets this bit to logical 0.
1	OER. Overrun Error. This bit is set to logical 1 to indicate that the received data have been overwritten by the next received data before they are read by the CPU. In 16550 mode, it indicates the same condition, instead of FIFO full. When the CPU reads USR, it sets this bit to logical 0.
0	RDR. RBR Data Ready. This bit is set to logical 1 to indicate that the received data are ready to be read by the CPU in the RBR or FIFO. When no data are left in the RBR or FIFO, the bit is set to logical 0.

10.2.3 Handshake Control Register (HCR) (Read/Write)

This register controls pins used with handshaking peripherals such as modems and also controls the diagnostic mode of the UART.

BIT	7	6	5	4	3	2	1	0
NAME	RESERVED			INTERNAL LOOPBACK ENABLE	IRQ ENABLE	LOOPBACK RI INPUT	RTS	DTR
DEFAULT	0	0	0	0	0	0	0	0

BIT	DESCRIPTION
7-5	RESERVED.
4	<p>INTERNAL LOOPBACK ENABLE. When this bit is set to logical 1, the UART enters diagnostic mode, as follows:</p> <ul style="list-style-type: none"> (1) SOUT is forced to logical 1, and SIN is isolated from the communication link. (2) The modem output pins are set to their inactive state. (3) The modem input pins are isolated from the communication link and connect internally as DTR(bit 0 of HCR) →DSR#, RTS (bit 1 of HCR) →CTS#, Loopback RI input (bit 2 of HCR) → RI# and IRQ enable (bit 3 of HCR) →DCD#. <p>Aside from the above connections, the UART operates normally. This method allows the CPU to test the UART in a convenient way.</p>
3	<p>IRQ ENABLE. The UART interrupt output is enabled by setting this bit to logical 1. In diagnostic mode, this bit is internally connected to the modem control input DCD#.</p>
2	<p>LOOPBACK RI INPUT. This bit is only used in the diagnostic mode. In diagnostic mode, this bit is internally connected to the modem control input RI#.</p>
1	<p>RTS. Request to Send. This bit controls the RTS# output. The value of this bit is inverted and output to RTS#.</p>
0	<p>DTR. Data Terminal Ready. This bit controls the DTR# output. The value of this bit is inverted and output to DTR#.</p>

10.2.4 Handshake Status Register (HSR) (Read/Write)

This register reflects the current state of the four input pins used with handshake peripherals such as modems and records changes on these pins.

BIT	7	6	5	4	3	2	1	0
NAME	DCD	RI	DSR	CTS	TDCD	FERI	TDSR	TCTS
DEFAULT	NA	NA	NA	NA	NA	NA	NA	NA

BIT	DESCRIPTION
7	<p>DCD. Data Carrier Detect. This bit is the opposite of the DCD# input. This bit is equivalent to bit 3 of HCR in the loopback mode.</p>
6	<p>RI. Ring Indicator. This bit is the opposite of the RI# input. This bit is equivalent to bit 2 of HCR in the loopback mode.</p>
5	<p>DSR. Data Set Ready. This bit is the opposite of the DSR# input. This bit is equivalent to bit 0 of HCR in the loopback mode.</p>
4	<p>CTS. Clear to Send. This bit is the opposite of the CTS# input. This bit is equivalent to bit</p>



BIT	DESCRIPTION
	1 of HCR in the loopback mode.
3	TDCD. DCD# Toggling. This bit indicates that the DCD# pin has changed state after HSR was read by the CPU.
2	FERI. RI Falling Edge. This bit indicates that the RI# pin has changed from low to high after HSR was read by the CPU.
1	TDSR. DSR# Toggling. This bit indicates that the DSR# pin has changed state after HSR was read by the CPU.
0	TCTS. CTS# Toggling. This bit indicates that the CTS# pin has changed state after HSR was read by the CPU.

10.2.5 UART FIFO Control Register (UFR) (Write only)

This register is used to control the FIFO functions of the UART.

BIT	7	6	5	4	3	2	1	0
NAME	RX IAL (MSB)	RXIAL (LSB)	RESERVED		DMA MODE SELECT	TRANSMITTER FIFO RESET	RECEIVER FIFO RESET	FIFO ENABLE
DEFAULT	0	0	NA	NA	0	0	0	0

BIT	DESCRIPTION
7	RX IAL (MSB). RX INTERRUPT ACTIVE LEVEL.
6	RX IAL (LSB). RX INTERRUPT ACTIVE LEVEL.
5-4	RESERVED.
3	DMA MODE SELECT. When this bit is set to logical 1, the DMA mode changes from mode 0 to mode 1 if UFR bit 0 = 1.
2	TRANSMITTER FIFO RESET. Setting this bit to logical 1 resets the TX FIFO counter logic to its initial state. This bit is automatically cleared afterwards.
1	RECEIVER FIFO RESET. Setting this bit to logical 1 resets the RX FIFO counter logic to its initial state. This bit is automatically cleared afterwards.
0	FIFO ENABLE. This bit enables 16550 mode. This bit should be set to logical 1 before the other UFR bits are programmed.

BIT 7	BIT 6	RX FIFO INTERRUPT ACTIVE LEVEL (BYTES)
-------	-------	--



0	0	01
0	1	04
1	0	08
1	1	14

10.2.6 Interrupt Status Register (ISR) (Read only)

This register reflects the UART interrupt status.

BIT	7	6	5	4	3	2	1	0
NAME	FIFOS ENABLED		RESERVED		INTERRUPT STATUS BIT2	INTERRUPT STATUS BIT1	INTERRUPT STATUS BIT0	0 IF INTERRUPT PENDING
DEFAULT	0	0	0	0	0	0	0	1

BIT	DESCRIPTION
7-6	FIFOS ENABLED. These two bits are set to logical 1 when UFR, bit 0 = 1.
5-4	RESERVED. These two bits are always logical 0.
3	INTERRUPT STATUS BIT2. In 16450 mode, this bit is logical 0. In 16550 mode, bit 3 and 2 are set to logical 1 when a time-out interrupts is pending. See the table below.
2	INTERRUPT STATUS BIT1.
1	INTERRUPT STATUS BIT0.
0	0 IF INTERRUPT PENDING. This bit is logical 1 if there is no interrupt pending. If one of the interrupt sources has occurred, this bit is set to logical 0.

ISR				INTERRUPT SET AND FUNCTION			
Bit 3	Bit 2	Bit 1	Bit 0	Interrupt priority	Interrupt Type	Interrupt Source	Clear Interrupt
0	0	0	1	-	-	No Interrupt pending	-
0	1	1	0	First	UART Receive Status	1. OER = 1 2. PBER =1 3. NSER = 1 4. SBD = 1	Read USR
0	1	0	0	Second	RBR Data Ready	1. RBR data ready 2. FIFO interrupt active level reached	1. Read RBR 2. Read RBR until FIFO data under active level
1	1	0	0	Second	FIFO Data Timeout	Data present in RX FIFO for 4 characters period of time since last access of RX FIFO.	Read RBR
0	0	1	0	Third	TBR Empty	TBR empty	1. Write data into TBR 2. Read ISR (if priority is third)



0	0	0	0	Fourth	Handshake status	1. TCTS = 1 2. TDSR = 1 3. FERI = 1 4. TDCD = 1	Read HSR
---	---	---	---	--------	------------------	--	----------

** Bit 3 of ISR is enabled when bit 0 of UFR is logical 1.

10.2.7 Interrupt Control Register (ICR) (Read/Write)

This 8-bit register enables and disables the five types of controller interrupts separately. A selected interrupt can be enabled by setting the appropriate bit to logical 1. The interrupt system can be totally disabled by setting bits 0 through 3 to logical 0.

BIT	7	6	5	4	3	2	1	0
NAME	RESERVED				EHSRI	EUSRI	ETBREI	ERDRI
DEFAULT	0	0	0	0	0	0	0	0

BIT	DESCRIPTION
7-4	RESERVED. These four bits are always logical 0.
3	EHSRI. Set this bit to logical 1 to enable the handshake status register interrupt.
2	EUSRI. Set this bit to logical 1 to enable the UART status register interrupt.
1	ETBREI. Set this bit to logical 1 to enable the TBR empty interrupt.
0	ERDRI. Set this bit to logical 1 to enable the RBR data ready interrupt.

10.2.8 Programmable Baud Generator (BLL/BHL) (Read/Write)

Two 8-bit registers, BLL and BHL, compose a programmable baud generator that uses 24 MHz to generate a 1.8461 MHz frequency and divide it by a divisor from 1 to ($2^{16} - 1$). The output frequency of the baud generator is the baud rate multiplied by 16, and this is the base frequency for the transmitter and receiver. The table below illustrates the use of the baud generator with a frequency of 1.8461 MHz. In high-speed UART mode (CR0C, bits 7 and 6), the programmable baud generator directly uses 24 MHz and the same divisor as the normal speed divisor. As a result, in high-speed mode, the data transmission rate can be as high as 1.5M bps.

BAUD RATE FROM DIFFERENT PRE-DIVIDER				
PRE-DIV: 13 1.8461M HZ	PRE-DIV:1.625 14.769M HZ	PRE-DIV: 1.0 24M HZ	DECIMAL DIVISOR USED TO GENERATE 16X CLOCK	ERROR PERCENTAGE
50	400	650	2304	**
75	600	975	1536	**
110	880	1430	1047	0.18%
134.5	1076	1478.5	857	0.099%
150	1200	1950	768	**
300	2400	3900	384	**

BAUD RATE FROM DIFFERENT PRE-DIVIDER				
PRE-DIV: 13 1.8461M HZ	PRE-DIV:1.625 14.769M HZ	PRE-DIV: 1.0 24M HZ	DECIMAL DIVISOR USED TO GENERATE 16X CLOCK	ERROR PERCENTAGE
600	4800	7800	192	**
1200	9600	15600	96	**
1800	14400	23400	64	**
2000	16000	26000	58	0.53%
2400	19200	31200	48	**
3600	28800	46800	32	**
4800	38400	62400	24	**
7200	57600	93600	16	**
9600	76800	124800	12	**
19200	153600	249600	6	**
38400	307200	499200	3	**
57600	460800	748800	2	**
115200	921600	1497600	1	**

** Unless specified, the error percentage for all of the baud rates is 0.16%.

Note: Pre-Divisor is determined by CRF0 of UART A and B.

10.2.9 User-defined Register (UDR) (Read/Write)

This is a temporary register that can be accessed and defined by the user.

11. Configuration Register

11.1 Plug and Play Configuration

The W83627HG/G uses Compatible PNP protocol to access configuration registers for setting up different types of configurations. In W83627HG/G, there are eleven Logical Devices (from Logical Device 0 to Logical Device B with the exception of logical device 4 for backward compatibility) which correspond to eleven individual functions: FDC (logical device 0), PRT (logical device 1), UART1 (logical device 2), UART2 (logical device 3), KBC (logical device 5), CIR (Consumer IR, logical device 6), GPIO1 (logical device 7), GPIO2 (logical device 8), GPIO3 (logical device 9), ACPI (logical device A), and hardware monitor (logical device B). Each Logical Device has its own configuration registers (above CR30). Host can access those registers by writing an appropriate logical device number into logical device select register at CR7.

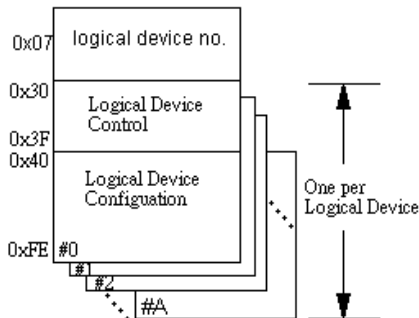

11.1.1 Compatible PnP

11.1.1.1. Extended Function Registers

In Compatible PnP, there are two ways to enter Extended Function and read or write the configuration registers. HEFRAS (CR26 bit 6) can be used to select one out of these two methods of entering the Extended Function mode as follows:

HEFRAS	address and value
0	write 87h to the location 2Eh twice
1	write 87h to the location 4Eh twice

After Power-on reset, the value on $\overline{\text{RTSA}}$ (pin 51) is latched by HEFRAS of CR26. In Compatible PnP, a specific value (87h) must be written twice to the Extended Functions Enable Register (I/O port address 2Eh or 4Eh). Secondly, an index value (02h, 07h ~ FFh) must be written to the Extended Functions Index Register (I/O port address 2Eh or 4Eh same as Extended Functions Enable Register) to identify which configuration register is to be accessed. The designer can then access the desired configuration register through the Extended Functions Data Register (I/O port address 2Fh or 4Fh).

After programming of the configuration register is finished, an additional value (AAh) should be written to EFERs to exit the Extended Function mode to prevent unintentional access to those configura-

tion registers. The designer can also set bit 5 of CR26 (LOCKREG) to high to protect the configuration registers against accidental accesses.

The configuration registers can be reset to their default or hardware settings only by a cold reset (pin LRESET = 1). A warm reset will not affect the configuration registers.

11.1.1.2. Extended Functions Enable Registers (EFERs)

After a power-on reset, the W83627HG/G enters the default operating mode. Before the W83627HG/G enters the extended function mode, a specific value must be programmed into the Extended Function Enable Register (EFER) so that the extended function register can be accessed. The Extended Function Enable Registers are write-only registers. On a PC/AT system, their port addresses are 2Eh or 4Eh (as described in previous section).

11.1.1.3. Extended Function Index Registers (EFIRs), Extended Function Data Registers (EFDRs)

After the extended function mode is entered, the Extended Function Index Register (EFIR) must be loaded with an index value (02h, 07h-FEh) to access Configuration Register 0 (CR0), Configuration Register 7 (CR07) to Configuration Register FE (CRFE), and so forth through the Extended Function Data Register (EFDR). The EFIRs are write-only registers with port address 2Eh or 4Eh (as described in section 12.2.1) on PC/AT systems; the EFDRs are read/write registers with port address 2Fh or 4Fh (as described in section 9.2.1) on PC/AT systems.

11.1.2 Configuration Sequence

To program W83627HG/G configuration registers, the following configuration sequence must be followed :

- (1) Enter the extended function mode
- (2) Configure the configuration registers
- (3) Exit the extended function mode

11.1.2.1. Enter the extended function mode

To place the chip into the extended function mode, two successive writes of 0x87 must be applied to Extended Function Enable Registers (EFERs, i.e. 2Eh or 4Eh).

11.1.2.2. Configure the configuration registers

The chip selects the logical device and activates the desired logical devices through Extended Function Index Register (EFIR) and Extended Function Data Register (EFDR). EFIR is located at the same address as EFER, and EFDR is located at address (EFIR+1).

First, write the Logical Device Number (i.e., 0x07) to the EFIR and then write the number of the desired logical device to the EFDR. If accessing the Chip (Global) Control Registers, this step is not required.

Secondly, write the address of the desired configuration register within the logical device to the EFIR and then write (or read) the desired configuration register through EFDR.

11.1.2.3. Exit the extended function mode

To exit the extended function mode, one write of 0xAA to EFER is required. Once the chip exits the extended function mode, it is in the normal running mode and is ready to enter the configuration mode.

11.1.2.4. Software programming example

The following example is written in Intel 8086 assembly language. It assumes that the EFER is located at 2Eh, so EFIR is located at 2Eh and EFDR is located at 2Fh. If HEFRAS (CR26 bit 6) is set, 4Eh can be directly replaced by 4Eh and 2Fh replaced by 4Fh.

```

;-----
; Enter the extended function mode ,interruptible double-write |
;-----
MOV DX,2EH
MOV AL,87H
OUT DX,AL
OUT DX,AL
;-----
; Configure logical device 1, configuration register CRF0 |
;-----
MOV DX,2EH
MOV AL,07H
OUT DX,AL          ; point to Logical Device Number Reg.
MOV DX,2FH
MOV AL,01H
OUT DX,AL          ; select logical device 1
;
MOV DX,2EH
MOV AL,F0H
OUT DX,AL          ; select CRF0
MOV DX,2FH
MOV AL,3CH
OUT DX,AL          ; update CRF0 with value 3CH
;-----
; Exit extended function mode |
;-----
MOV DX,2EH
MOV AL,AAH
OUT DX,AL

```

11.2 Chip (Global) Control Register

CR02 (Default 0x00)

Bit	Description
7 - 1	Reserved.
0	SWRST --> Soft Reset.

CR07

Bit 7 - 0 : Logical Device Number

CR20

Bit 7 - 0 : Device ID = **0x52** (read only) .

CR21

Bit 7 - 0 : Device Rev (read only) .

Version	Device Rev
G	17
J	3A
UD-A	41

CR22 (Default 0xff)

Bit	Description
7	Reserved.
6	HMPWD 0 : Power down 1 : No Power down
5	URBPWD 0 : Power down 1 : No Power down
4	URAPWD 0 : Power down 1 : No Power down
3	PRTPWD 0 : Power down 1 : No Power down
2 - 1	Reserved.
0	FDCPWD 0 : Power down 1 : No Power down

CR23 (Default 0x00)

Bit	Description
7 - 1	Reserved.
0	IPD (Immediate Power Down) . When set to 1, it will put the whole chip into power down mode immediately.

CR24 (Default 0b1s000s0s)

Bit	Description
7	EN16SA 0 : 12 bit Address Qualification 1 : 16 bit Address Qualification
6	CLKIN 0 : The clock input on Pin 1 should be 24 Mhz. 1 : The clock input on Pin 1 should be 48 Mhz. The corresponding power-on setting pin is SOUTB (pin 83) .
5 - 3	Reserved
2	ENKBC (Read Only) 0 : KBC is disabled after hardware reset. 1 : KBC is enabled after hardware reset. This bit is set/reset by power-on setting pin SOUTA (pin 54) .
1	Reserved
0	PNPCVS 0 : The Compatible PnP address select registers have default values. 1 : The Compatible PnP address select registers have no default value. When trying to make a change to this bit, new value of PNPCVS must be complementary to the old one to make an effective change. For example, the user must set PNPCVS to 0 first and then reset it to 1 to reset these PnP registers if the present value of PNPCVS is 1. The corresponding power-on setting pin is NDTRA (pin 52) .

CR25 (Default 0x00)

Bit	Description
7 - 6	Reserved
5	URBTRI. UART2 output pin tri-stated.
4	URATRI. UART1 output pin tri-stated.
3	PRTTRI. Parallel port output pin tri-stated.
2 - 1	Reserved
0	FDCTRI. FDC output pin tri-stated.

CR26 (Default 0b0s000000)

Bit	Description
7	SEL4FDD 0 : Select two FDD mode. 1 : Select four FDD mode.
6	HEFRAS These two bits define how to enable Configuration mode. The corresponding power-on setting pin is NRTSA (pin 51) . HEFRAS Address and Value 0 : Write 87h to the location 2E twice. 1 : Write 87h to the location 4E twice.
5	LOCKREG 0 : Enable R/W Configuration Registers 1 : Disable R/W Configuration Registers.
4	Reserve
3	DSFDLGRQ 0 : Enable FDC legacy mode on IRQ and DRQ selection, then DO register bit 3 is effective on selecting IRQ 1 : Disable FDC legacy mode on IRQ and DRQ selection, then DO register bit 3 is not effective on selecting IRQ
2	DSPRLGRQ 0 : Enable PRT legacy mode on IRQ and DRQ selection, then DCR bit 4 is effective on selecting IRQ 1 : Disable PRT legacy mode on IRQ and DRQ selection, then DCR bit 4 is not effective on selecting IRQ
1	DSUALGRQ 0 : Enable UART A legacy mode IRQ selecting, then MCR bit 3 is effective on selecting IRQ 1 : Disable UART A legacy mode IRQ selecting, then MCR bit 3 is not effective on selecting IRQ
0	DSUBLGRQ 0 : Enable UART B legacy mode IRQ selecting, then MCR bit 3 is effective on selecting IRQ 1 : Disable UART B legacy mode IRQ selecting, then MCR bit 3 is not effective on selecting IRQ

CR28 (Default 0x00)

Bit	Description
7 - 3	Reserved.
2 - 0	PRTMODS2 - PRTMODS0 0xx : Parallel Port Mode 100 : Reserved 101 : External FDC Mode 110 : Reserved 111 : External two FDC Mode

CR29 (GPIO3 multiplexed pin selection register. VBAT powered. Default 0x00)

Bit	Description
7	PIN64S 0 : SUSLED (SUSLED control bits are in CRF3 of Logical Device 9) 1 : GP35
6	PIN69S 0 : CIRRX# 1 : GP34
5	PIN70S 0 : RSMRST# 1 : GP33
4	PIN71S 0 : PWROK 1 : GP32
3	PIN72S 0 : PWRCTL# 1 : GP31
2	PIN 73S 0 : SLP_SX# 1 : GP30
1	Reserved
0	Reserved

CR2A (GPIO multiplexed pin selection register 1. VCC powered. Default 0X7C)

Bit	Description
7	Port Select (select Game Port or General Purpose I/O Port 1) 0 : Game Port 1 : General Purpose I/O Port 1 (pin121~128 select function GP10~GP17 or KBC Port 1)
6	PIN128S 0 : 8042 P12 1 : GP10
5	PIN127S 0 : 8042 P13 1 : GP11
4	PIN126S 0 : 8042 P14 1 : GP12
3	PIN125S 0 : 8042 P15 1 : GP13
2	PIN124S 0 : 8042 P16 1 : GP14
1	PIN120S 0 : MSO (MIDI Serial Output) 1 : IRQIN0 (select IRQ resource through CRF4 Bit 7-4 of Logical Device 8)
1	PIN119S 0 : MS1 (MIDI Serial Input) 1 : GP20

CR2B (GPIO multiplexed pin selection register 2. VCC powered. Default 0XC0)

Bit	Description
7	PIN92S 0 : SCL 1 : GP21
6	PIN91S 0 : SDA 1 : GP22
5	PIN90S 0 : PLED (PLED0 control bits are in CRF5 of Logical Device 8) 1 : GP23

Bit	Description
4	PIN89S 0 : WDTO (Watch Dog Timer is controlled by CRF5, CRF6, CRF7 of Logical Device 8) 1 : GP24
3	PIN88S 0 : IRRX 1 : GP25
2	PIN87S 0 : IRTX 1 : GP26
1-0	PIN 2S 00 : DRVDEN1 01 : SMI# 10 : IRQIN1 (select IRQ resource through CRF4 Bit 7-4 of Logical Device8) 11 : GP27

CR2C (Default 0x00)

Reserved

CR2E (Default 0x00)

Test Modes : Reserved for Winbond.

CR2F (Default 0x00)

Test Modes : Reserved for Winbond.

11.3 Logical Device 0 (FDC)**CR30 (Default 0x01 if PNPCVS = 0 during POR, default 0x00 otherwise)**

Bit	Description
7 - 1	Reserved.
0	Logic device activation control 1 : Active 0 : Inactived

CR60, CR 61 (Default 0x03, 0xf0 if PNPCVS = 0 during POR, default 0x00, 0x00 otherwise)

These two registers select FDC I/O base address [0x100 : 0xFF8] on 8 bytes boundary.

CR70 (Default 0x06 if PNPCVS = 0 during POR, default 0x00 otherwise)

Bit	Description
7 - 4	Reserved.
3 - 0	These bits select IRQ resource for FDC.

CR74 (Default 0x02 if PNPCVS = 0 during POR, default 0x04 otherwise)

Bit	Description
7 - 3	Reserved.
2 - 0	These bits select DRQ resource for FDC. 000 : DMA0 001 : DMA1 010 : DMA2 011 : DMA3 100 ~ 111 : No DMA active

CRF0 (Default 0x0E)**FDD Mode Register**

Bit	Description
7	FIPURDWN This bit controls the internal pull-up resistors of the FDC input pins RDATA, INDEX, TRAK0, DSKCHG, and WP. 0 : The internal pull-up resistors of FDC are turned on. (Default) 1 : The internal pull-up resistors of FDC are turned off.
6	INVERTZ This bit determines the polarity of all FDD interface signals. 0 : FDD interface signals are active low. 1 : FDD interface signals are active high.
5	DRV2EN (PS2 mode only) When this bit is a logic 0, indicates a second drive is installed and is reflected in status register A.
4	Swap Drive 0, 1 Mode 0 : No Swap (Default) 1 : Drive and Motor sel 0 and 1 are swapped.
3 - 2	Interface Mode 11 : AT Mode (Default) 10 : Reserved 01 : PS/2 00 : Model 30
1	FDC DMA Mode 0 : Burst Mode is enabled 1 : Non-Burst Mode (Default)



0	Floppy Mode 0 : Normal Floppy Mode (Default) 1 : Enhanced 3-mode FDD
---	--

CRF1 (Default 0x00)

Bit	Description
7 - 6	Boot Floppy 00 : FDD A 01 : FDD B 10 : FDD C 11 : FDD D
5 - 4	Media ID1, Media ID0. These bits will be reflected on FDC's Tape Drive Register bit 7, 6.
3 - 2	Density Select 00 : Normal (Default) 01 : Normal 10 : 1 (Forced to logic 1) 11 : 0 (Forced to logic 0)
1	DISFDDWR 0 : Enable FDD write. 1 : Disable FDD write (forces pins WE, WD stay high) .
0	SWWP 0 : Normal, use WP to determine whether the FDD is write protected or not. 1 : FDD is always write-protected.

CRF2 (Default 0xFF)

Bit	Description
7 - 6	FDD D Drive Type
5 - 4	FDD C Drive Type
3 - 2	FDD B Drive Type
1 - 0	FDD A Drive Type

CRF4 (Default 0x00)**FDD0 Selection :**

Bit	Description
7	Reserved.
6	Precomp. Disable. 1 : Disable FDC Precompensation. 0 : Enable FDC Precompensation.



Bit	Description
5	Reserved.
4 - 3	DRTS1, DRTS0 : Data Rate Table select (Refer to TABLE A) . 00 : Select Regular drives and 2.88 format 01 : 3-mode drive 10 : 2 Meg Tape 11 : Reserved
2	Reserved.
1 - 0	DTYPE0, DTYPE1 : Drive Type select (Refer to TABLE B) .

CRF5 (Default 0x00)

FDD1 Selection : Same as FDD0 of CRF4.

TABLE A

Drive Rate Table Select		Data Rate		Selected Data Rate		SELDEN
DRTS1	DRTS0	DRATE1	DRATE0	MFM	FM	
0	0	1	1	1Meg	---	1
		0	0	500K	250K	1
		0	1	300K	150K	0
		1	0	250K	125K	0
0	1	1	1	1Meg	---	1
		0	0	500K	250K	1
		0	1	500K	250K	0
		1	0	250K	125K	0
1	0	1	1	1Meg	---	1
		0	0	500K	250K	1
		0	1	2Meg	---	0
		1	0	250K	125K	0

TABLE B

DTYPE0	DTYPE1	DRV DEN0 (pin 1)	DRV DEN1 (pin 2)	DRIVE TYPE
0	0	SELDEN	DRATE0	4/2/1 MB 3.5" 2/1 MB 5.25" 2/1.6/1 MB 3.5" (3-MODE)
0	1	DRATE1	DRATE0	
1	0	SELDEN	DRATE0	
1	1	DRATE0	DRATE1	

11.4 Logical Device 1 (Parallel Port)

CR30 (Default 0x01 if PNPCVS = 0 during POR, default 0x00 otherwise)

Bit	Description
7 - 1	Reserved.
0	Logic device activation control 1 : Active 0 : Inactivated

CR60, CR 61 (Default 0x03, 0x78 if PNPCVS = 0 during POR, default 0x00, 0x00 otherwise)

These two registers select Parallel Port I/O base address.

[0x100 : 0xFFC] on 4 byte boundary (EPP not supported) or [0x100 : 0xFF8] on 8 byte boundary (all modes supported, EPP is only available when the base address is on 8 byte boundary) .

CR70 (Default 0x07 if PNPCVS = 0 during POR, default 0x00 otherwise)

Bit	Description
7 - 4	Reserved.
3 - 0	These bits select IRQ resource for Parallel Port.

CR74 (Default 0x04)

Bit	Description
7 - 3	Reserved.
2 - 0	These bits select DRQ resource for Parallel Port. 000 : DMA0 001 : DMA1 010 : DMA2 011 : DMA3 100 ~ 111 : No DMA active

CRF0 (Default 0x3F)

Bit	Description
7	Reserved.
6 - 3	ECP FIFO Threshold.

Bit	Description
2 - 0	Parallel Port Mode (CR28 PRTMODS2 = 0) 100 : Printer Mode (Default) 000 : Standard and Bi-direction (SPP) mode 001 : EPP - 1.9 and SPP mode 101 : EPP - 1.7 and SPP mode 010 : ECP mode 011 : ECP and EPP - 1.9 mode 111 : ECP and EPP - 1.7 mode

11.5 Logical Device 2 (UART A)

CR30 (Default 0x01 if PNPCVS = 0 during POR, default 0x00 otherwise)

Bit	Description
7 - 1	Reserved.
0	Logic device activation control 1 : Active 0 : Inactived

CR60, CR 61 (Default 0x03, 0xF8 if PNPCVS = 0 during POR, default 0x00, 0x00 otherwise)

These two registers select Serial Port 1 I/O base address [0x100 : 0xFF8] on 8 byte boundary.

CR70 (Default 0x04 if PNPCVS = 0 during POR, default 0x00 otherwise)

Bit	Description
7 - 4	Reserved.
3 - 0	These bits select IRQ resource for Serial Port 1.

CRF0 (Default 0x00)

Bit	Description
7 - 2	Reserved.
1 - 0	SUACLKB1, SUACLKB0 00 : UART A clock source is 1.8462 Mhz (24MHz/13) 01 : UART A clock source is 2 Mhz (24MHz/12) 10 : UART A clock source is 24 Mhz (24MHz/1) 11 : UART A clock source is 14.769 Mhz (24mhz/1.625)

11.6 Logical Device 3 (UART B)

CR30 (Default 0x01 if PNPCVS = 0 during POR, default 0x00 otherwise)

Bit	Description
7 - 1	Reserved.
0	Logic device activation control 1 : Active 0 : Inactived

CR60, CR 61 (Default 0x02, 0xF8 if PNPCVS = 0 during POR, default 0x00, 0x00 otherwise)

These two registers select Serial Port 2 I/O base address [0x100 : 0xFF8] on 8 byte boundary.

CR70 (Default 0x03 if PNPCVS = 0 during POR, default 0x00 otherwise)

Bit	Description
7 - 4	Reserved.
3 - 0	These bits select IRQ resource for Serial Port 2.

CRF0 (Default 0x00)

Bit	Description
7 - 4	Reserved.
3	RXW4C 0 : No reception delay when IR is changed from TX mode to RX mode. 1 : Reception delays 4 characters time (40 bit-time) when SIR is changed from TX mode to RX mode.
2	TXW4C 0 : No transmission delay when SIR is changed from RX mode to TX mode. 1 : Transmission delays 4 characters time (40 bit-time) when SIR is changed from RX mode to TX mode.
1 - 0	SUBCLKB1, SUBCLKB0 00 : UART B clock source is 1.8462 Mhz (24MHz/13) 01 : UART B clock source is 2 Mhz (24MHz/12) 10 : UART B clock source is 24 Mhz (24MHz/1) 11 : UART B clock source is 14.769 Mhz (24mhz/1.625)

CRF1 (Default 0x00)

Bit	Description
7	Reserved.
6	IRLOCSEL. IR I/O pins' location select. 0 : Through SINB/SOUTB. 1 : Through IRRX/IRTX.
5	IRMODE2. IR function mode selection bit 2.
4	IRMODE1. IR function mode selection bit 1.
3	IRMODE0. IR function mode selection bit 0.

IR MODE	IR FUNCTION	IRTX	IRRX
00X	Disable	tri-state	high
010*	IrDA	Active pulse 1.6 μ S	Demodulation into SINB/IRRX
011*	IrDA	Active pulse 3/16 bit time	Demodulation into SINB/IRRX
100	ASK-IR	Inverting IRTX/SOUTB pin	routed to SINB/IRRX
101	ASK-IR	Inverting IRTX/SOUTB & 500 KHZ clock	routed to SINB/IRRX
110	ASK-IR	Inverting IRTX/SOUTB	Demodulation into SINB/IRRX
111*	ASK-IR	Inverting IRTX/SOUTB & 500 KHZ clock	Demodulation into SINB/IRRX

Note : The notation is normal mode in the IR function.

Bit	Description
2	HDUPLX. IR half/full duplex function select. 0 : The IR function is Full Duplex. 1 : The IR function is Half Duplex.
1	TX2INV 0 : the SOUTB pin of UART B function or IRTX pin of IR function in normal condition. 1 : inverse the SOUTB pin of UART B function or IRTX pin of IR function.
0	RX2INV. 0 : the SINB pin of UART B function or IRRX pin of IR function in normal condition. 1 : Inverse the SINB pin of UART B function or IRRX pin of IR function

11.7 Logical Device 5 (KBC)

CR30 (Default 0x01 if PNPCVS = 0 during POR, default 0x00 otherwise)

Bit	Description
7 - 1	Reserved.
0	Logic device activation control. 1 : Active 0 : Inactived

CR60, CR 61 (Default 0x00, 0x60 if PNPCVS = 0 during POR, default 0x00 otherwise)

These two registers select the first KBC I/O base address [0x100 : 0xFFFF] on 1 byte boundary.

CR62, CR 63 (Default 0x00, 0x64 if PNPCVS = 0 during POR, default 0x00 otherwise)

These two registers select the second KBC I/O base address [0x100 : 0xFFFF] on 1 byte boundary.

CR70 (Default 0x01 if PNPCVS = 0 during POR, default 0x00 otherwise)

Bit	Description
7 - 4	Reserved.
3 - 0	These bits select IRQ resource for KINT (keyboard) .

CR72 (Default 0x0C if PNPCVS = 0 during POR, default 0x00 otherwise)

Bit	Description
7 - 4	Reserved.
3 - 0	These bits select IRQ resource for MINT (PS2 Mouse)

CRF0 (Default 0x80)

Bit	Description
7 - 6	KBC clock rate selection 00 : Select 6MHz as KBC clock input. 01 : Select 8MHz as KBC clock input. 10 : Select 12Mhz as KBC clock input. 11 : Select 16Mhz as KBC clock input.
5 - 3	Reserved.
2	0 : Port 92 disable. 1 : Port 92 enable.
1	0 : Gate20 software control. 1 : Gate20 hardware speed up.
0	0 : KBRST software control. 1 : KBRST hardware speed up.

11.8 Logical Device 6 (CIR)

CR30 (Default 0x00)

Bit	Description
7 - 1	Reserved.
0	Logic device activation control 1 : Active 0 : Inactived

CR60, CR 61 (Default 0x00, 0x00)

These two registers select CIR I/O base address [0x100 : 0xFF8] on 8 byte boundary.

CR70 (Default 0x00)

Bit	Description
7 - 4	Reserved.
3 - 0	These bits select IRQ resource for CIR.

11.9 Logical Device 7 (Game Port, MIDI Port and GPIO Port 1)

CR30 (Default 0x00)

Bit	Description
7 - 3	Reserved
2	MIDI Port activation control 1 : Enable (MIDI Port will be active individually even though CR30[0] is set "0") 0 : Disbale
1	Game Port activation control 1 : Enable (Game Port will be active individually even though CR30[0] is set "0") 0 : Disable
0	Logic device activation control 1 : Active 0 : Inactived

CR60, CR 61 (Default 0x02, 0x01 if PNPCVS = 0 during POR, default 0x00 otherwise)

These two registers select the Game Port base address [0x100 : 0xFFFF] on 1 byte boundary.

CR62, CR 63 (Default 0x03, 0x30 if PNPCVS = 0 during POR, default 0x00 otherwise)

These two registers select the MIDI Port base address [0x100 : 0xFFFF] on 2 byte boundary.

CR70 (Default 0x09 if PNPCVS = 0 during POR, default 0x00 otherwise)

Bit	Description
7 - 4	Reserved.
3 - 0	These bits select IRQ resource for MIDI Port.

CRF0 (GP10-GP17 I/O selection register. Default 0xFF)

When set to a '1', respective GPIO port is programmed as an input port.

When set to a '0', respective GPIO port is programmed as an output port.

CRF1 (GP10-GP17 data register. Default 0x00)

If a port is programmed to be an output port, then its respective bit can be read/written.

If a port is programmed to be an input port, then its respective bit can only be read.

CRF2 (GP10-GP17 inversion register. Default 0x00)

When set to a '1', the incoming/outgoing port value is inverted.

When set to a '0', the incoming/outgoing port value is the same as in data register.

CRF3 (Reserved)

This register is reserved.

11.10 Logical Device 8 (GPIO Port 2 and Watch Dog Timer)**CR30 (Default 0x00)**

Bit	Description
7 - 1	Reserved.
0	Logic device activation control 1 : Active 0 : Inactive

CRF0 (GP20-GP27 I/O selection register. Default 0xFF)

When set to a '1', respective GPIO port is programmed as an input port.

When set to a '0', respective GPIO port is programmed as an output port.

CRF1 (GP20-GP27 data register. Default 0x00)

If a port is programmed to be an output port, then its respective bit can be read/written.

If a port is programmed to be an input port, then its respective bit can only be read.

CRF2 (GP20-GP27 inversion register. Default 0x00)

When set to a '1', the incoming/outgoing port value is inverted.

When set to a '0', the incoming/outgoing port value is the same as in data register.

CRF3 (Default 0x00)

Bit	Description
7 - 4	These bits select IRQ resource for IRQIN1.
3 - 0	These bits select IRQ resource for IRQIN0.

CRF4 (Reserved)

This register is reserved..

CRF5 (PLED mode register. Default 0x00)

Bit	Description
7 - 6	PLED mode select 00 : Power LED pin is tri-stated. 01 : Power LED pin is driven low. 10 : Power LED pin is a 1Hz toggle pulse with 50 duty cycle 11 : Power LED pin is a 1/4Hz toggle pulse with 50 duty cycle.
5 - 4	Reserved
3	WDTO count mode select 0 : Second 1 : Minute
2	Enable the rising edge of keyboard Reset (P20) to force Time-out event. 0 : Disable 1 : Enable
1 - 0	Reserved

CRF6 (Default 0x00)

Watch Dog Timer Time-out value. Writing a non-zero value to this register causes the counter to load the value to Watch Dog Counter and start counting down. If the Bit 7 and Bit 6 are set, any Mouse Interrupt or Keyboard Interrupt event will also cause the reload of previously-loaded non-zero value to Watch Dog Counter and start counting down. Reading this register returns current value in Watch Dog Counter instead of Watch Dog Timer Time-out value.

Bit	Description
7 - 0	0x00 Time-out Disable 0x01 Time-out occurs after 1 sec / min 0x02 Time-out occurs after 2 sec / min 0x03 Time-out occurs after 3 sec / min . . . 0xFF Time-out occurs after 255 sec / min

CRF7 (Default 0x00)

Bit	Description
7	Mouse interrupt reset Enable or Disable 1 : Watch Dog Timer is reset upon a Mouse interrupt 0 : Watch Dog Timer is not affected by Mouse interrupt
6	Keyboard interrupt reset Enable or Disable 1 : Watch Dog Timer is reset upon a Keyboard interrupt 0 : Watch Dog Timer is not affected by Keyboard interrupt
5	Force Watch Dog Timer Time-out, Write only 1 : Force Watch Dog Timer time-out event; this bit is self-clearing.
4	Watch Dog Timer Status, R/W 1 : Watch Dog Timer time-out occurred 0 : Watch Dog Timer counting
3 -0	These bits select IRQ resource for Watch Dog. Setting of 2 selects SMI.

11.11 Logical Device 9 (GPIO Port 3, VSB powered)**CR30 (Default 0x00)**

Bit	Description
7 - 1	Reserved
0	Logic device activation control 1 : Active 0 : Inactivated

CRF0 (GP30-GP35 I/O selection register. Default 0xFF Bit 7-6 : Reserve)

When set to a '1', respective GPIO port is programmed as an input port.

When set to a '0', respective GPIO port is programmed as an output port.

CRF1 (GP30-GP35 data register. Default 0x00 Bit 7-6 : Reserve)

If a port is programmed to be an output port, then its respective bit can be read/written.

If a port is programmed to be an input port, then its respective bit can only be read.

CRF2 (GP30-GP35 inversion register. Default 0x00 Bit 7-6 : Reserve)

When set to a '1', the incoming/outgoing port value is inverted.

When set to a '0', the incoming/outgoing port value is the same as in data register.

CRF3 (SUSLED mode register. Default 0x00)

Bit	Description
7-6	Select Suspend LED mode. (VSB powered) 00 : Suspend LED pin is driven low. 01 : Suspend LED pin is tri-stated. 10 : Suspend LED pin is a 1Hz toggle pulse with 50 duty cycle. 11 : Suspend LED pin is a 1/4Hz toggle pulse with 50 duty cycle.
5 - 0	Reserved.

11.12 Logical Device A (ACPI)**CR30 (Default 0x00)**

Bit	Description
7 - 1	Reserved.
0	Logic device activation control 1 : Active 0 : Inactive

CR70 (Default 0x00)

Bit	Description
7 - 4	Reserved.
3 - 0	These bits select IRQ resources for \overline{PME} .

CRE0 (Default 0x00)

Bit	Description
7	DIS-PANSW_IN. Disable panel switch input to turn system power supply on. 0 : PANSW_IN is wire-ANDed and connected to PANSW_OUT. 1 : PANSW_IN is blocked and can not affect PANSW_OUT.
6	ENKBWAKEUP. Enable Keyboard to wake-up system via PANSW_OUT. 0 : Disable Keyboard wake-up function. 1 : Enable Keyboard wake-up function.
5	ENMSWAKEUP. Enable Mouse to wake-up system via PANSW_OUT. 0 : Disable Mouse wake-up function. 1 : Enable Mouse wake-up function.
4	MSRKEY. Select Mouse Left/Right Botton to wake-up system via PANSW_OUT. 0 : Select click on Mouse Left-bottom to wake the system up. 1 : Select click on Mouse right-bottom to wake the system up.

Bit	Description
3	ENCIRWAKEUP. Enable CIR to wake-up system via PANSW_OUT. 0 : Disable CIR wake-up function. 1 : Enable CIR wake-up function.
2	KB/MS Swap. Enable Keyboard/Mouse port-swap. 0 : Keyboard/Mouse ports are not swapped. 1 : Keyboard/Mouse ports are swapped.
1	MSXKEY. Select either single or double click to wake-up the system. 0 : Indicates mouse double click can wake the system up. 1 : Indicates mouse single click can wake the system up.
0	KBXKEY. Enable any character received from Keyboard to wake-up the system 0 : Only predetermined specific key combination can wake up the system. 1 : Any character received from Keyboard can wake up the system.

CRE1 (Default 0x00) Keyboard Password Wake-Up Index Register

This register is used to indicate which Keyboard Wake-Up Shift register or predetermined key Register is to be read or written via CRE2.

CRE2 Keyboard Password Wake-Up Data Register

This register holds the value of wake-up key register indicated by CRE1.

W83627HG supports at most 5-key password wake-up function. CRE1 is an index register to indicate which byte of key code storage (0X00 ~ 0X0E) is going to be read or written. According to IBM 101/102 keyboard specification, a complete key code contains a 1-byte make code and a 2-byte break code. For example. The make code of Key "0" is 0x45, and the corresponding break code is 0xF0, 0x45. The approach to implement Keyboard Password Wake-up function is to fill key codes into the password storage. Assume that we want to set "012" as the password. The storage must be filled as below. Please note that index 0x09 ~ 0x0e must be filled as 0x00 since the password has only three words.

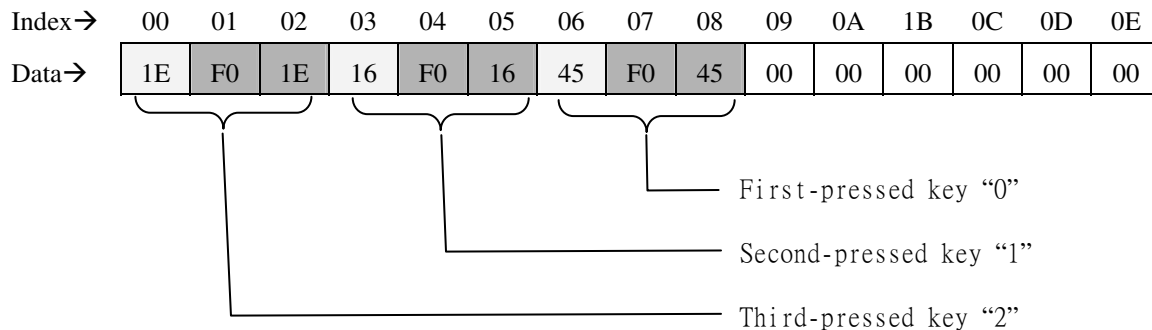

CRE3 Keyboard/Mouse Wake-Up Status Register (Read Only)

Bit	Description
7-6	Reserved.
5	When 1 is VSB Power Loss status.
4	PWRLOSS_STS . This bit is set when power loss occurs. This bit is control by CRE4[7]
3	CIR_STS . The Panel switch event is caused by CIR wake-up event. This bit is cleared by reading this register.
2	PANSW_STS . The Panel switch event is caused by PANSW_IN. This bit is cleared by reading this register.
1	MOUSE_STS . The Panel switch event is caused by Mouse wake-up event. This bit is cleared by reading this register.
0	KB_STS . The Panel switch event is caused by Keyboard wake-up event. This bit is cleared by reading this register.

CRE4 (Default 0x00)

Bit	Description
7	Power loss control bit 2. 0 : Indicates that PWRCTL# (Pin 72) outputs logic low after PSOUT# issues a low pluse. 1 : Indicates that PWRCTL# will output logic low after resum from AC power loss if SLP_SX (Pin 73) is logic high.
6-5	Power loss control bit <1 : 0> 00 : System always turn off when come back from power loss state. 01 : System always turn on when come back from power loss state. 10 : System turn on/off when come back from power loss state depend on the state before power loss. 11 : Reserved.
4	Suspend clock source select 0 : Use internal clock source. 1 : Use external suspend clock source (32.768KHz) .
3	Keyboard wake-up type select for wake-up the system from S1/S2. 0 : Password or Hot keys programmed in the registers. 1 : Any key.
2	Enable all wake-up event set in CRE0 can wake-up the system from S1/S2 state. This bit is cleared when wake-up event occurs. 0 : Disable. 1 : Enable.
1 - 0	Reserved.

CRE5 (Default 0x00)

Bit	Description
7	Reserved
6 - 0	Compared Code Length. When the compared codes are stored in the data register, these data length should be written to this register.

CRE6 (Default 0x00)

Bit	Description
7	Reserved
6	Chassis Status Clear. (availible for A Version only) 1 : Clear CASEOPEN# (Pin 76) event. 0 : Disable clear function. Set this bit to "1" will make hardware monitor register index 42, bit 4 cleared unceasingly. Therefore, next Case-open Event can not be triggered again until this bit is cleared to "0". This bit is available for W83627HG A Version only, please refer to Hardware Monitor Register Index 46, bit 7 for other version.
5 - 0	CIR Baud Rate Divisor. The clock base of CIR is 32khz, so that the baud rate is 32khz divided by (CIR Baud Rate Divisor + 1) .

CRE7 (Default 0x00)

Bit	Description
7	Reserved.
6	Reserved.
5	Reserved.
4	Reserved.
3	SELWDTORST. Watch Dog Timer Reset Control. 0 : Indicates that Watch Dog Timer is reset by LPC_RST. 1 : Indicates that Watch Dog Timer is reset by PWR_OK.
2	Reset CIR Power-On function. After using CIR power-on, the software should write logical 1 to restart CIR power-on function.
1	Invert RX Data. 1 : Inverting RX Data. 0 : Not inverting RX Data.
0	Enable Demodulation. 1 : Enable received signal to demodulate. 0 : Disable received signal to demodulate.

CRF0 (Default 0x00)

Bit	Description
7	CHIPPME. Chip level auto power management enable. 0 : Disable the auto power management functions 1 : Enable the auto power management functions.
6	CIRPME. Consumer IR port auto power management enable. 0 : Disable the auto power management functions 1 : Enable the auto power management functions.
5	MIDIPME. MIDI port auto power management enable. 0 : Disable the auto power management functions 1 : Enable the auto power management functions.
4	Reserved. Return zero when read.
3	PRTPME. Printer port auto power management enable. 0 : Disable the auto power management functions. 1 : Enable the auto power management functions.
2	FDCPME. FDC auto power management enable. 0 : Disable the auto power management functions. 1 : Enable the auto power management functions.
1	URAPME. UART A auto power management enable. 0 : Disable the auto power management functions. 1 : Enable the auto power management functions.
0	URBPME. UART B auto power management enable. 0 : Disable the auto power management functions. 1 : Enable the auto power management functions.

CRF1 (Default 0x00)

Bit	Description
7	WAK_STS. This bit is set when the chip is in the sleeping state and an enabled resume event occurs. Upon setting this bit, the sleeping/working state machine will transition the system to the working state. This bit is only set by hardware and is cleared by writing a 1 to this bit position or by the sleeping/working state machine automatically when the global standby timer expires. 0 : the chip is in the sleeping state. 1 : the chip is in the working state.
6	CIR_STS. 0: CIR is in the sleeping state. 1: CIR is in the working state
5	MIDI_STS. 0: MIDI is in the sleeping state. 1: MIDI is in the working state
4	Reserved. Return zero when read.
3	PRT_STS. 0: PRT is in the sleeping state. 1: PRT is in the working state
2	FDC_STS. 0: FDC is in the sleeping state. 1: FDC is in the working state
1	URA_STS. 0: URA is in the sleeping state. 1: URA is in the working state
0	URB_STS. 0: URB is in the sleeping state. 1: URB is in the working state

CRF3 (Default 0x00)

Bit	Description
7 - 6	Reserved. Return zero when read.
5 - 0	Device's IRQ status. These bits indicate the IRQ status of the individual device respectively. The device's IRQ status bit is set by their source device and is cleared by writing a 1. Writing a 0 has no effect.
5	MOUIRQSTS. MOUSE IRQ status.
4	KBCIRQSTS. KBC IRQ status.
3	PRTIRQSTS. printer port IRQ status.
2	FDCIRQSTS. FDC IRQ status.
1	URAIRQSTS. UART A IRQ status.
0	URBIRQSTS. UART B IRQ status.

CRF4 (Default 0x00)

Bit	Description
7 - 6	Reserved. Return zero when read.
5 - 0	These bits indicate the IRQ status of the individual GPIO function or logical device respectively. The status bit is set by their source function or device and is cleared by writing a 1. Writing a 0 has no effect.
5	HMIRQSTS. Hardware monitor IRQ status.
4	WDTIRQSTS. Watch dog timer IRQ status.
3	CIRIRQSTS. Consumer IR IRQ status.
1	IRQIN1STS. IRQIN1 status.
0	IRQIN0STS. IRQIN0 status.

CRF6 (Default 0x00)

Bit	Description
7 - 6	Reserved. Return zero when read.
5 - 0	Enable bits of the $\overline{\text{SMI}}/\overline{\text{PME}}$ generation due to the device's IRQ. These bits enable the generation of a $\overline{\text{SMI}}/\overline{\text{PME}}$ interrupt due to any IRQ of the devices. $\overline{\text{SMI}}/\overline{\text{PME}}$ logic output = (MOUIRQEN and MOUIRQSTS) or (KBCIRQEN and KBCIRQSTS) or (PRTIRQEN and PRTIRQSTS) or (FDCIRQEN and FDCIRQSTS) or (URAIRQEN and URAIRQSTS) or (URBIRQEN and URBIRQSTS) or (HMIRQEN and HMIRQSTS) or (WDTIRQEN and WDTIRQSTS) or (IRQIN3EN and IRQIN3STS) or (IRQIN2EN and IRQIN2STS) or (IRQIN1EN and IRQIN1STS) or (IRQIN0EN and IRQIN0STS)
5	MOUIRQEN. 0 : Disable the generation of an $\overline{\text{SMI}}/\overline{\text{PME}}$ interrupt due to MOUSE's IRQ. 1 : Enable the generation of an $\overline{\text{SMI}}/\overline{\text{PME}}$ interrupt due to MOUSE's IRQ.

Bit	Description
4	KBCIRQEN. 0 : Disable the generation of an $\overline{\text{SMI}}/\overline{\text{PME}}$ interrupt due to KBC's IRQ. 1 : Enable the generation of an $\overline{\text{SMI}}/\overline{\text{PME}}$ interrupt due to KBC's IRQ.
3	PRTIRQEN. 0 : Disable the generation of an $\overline{\text{SMI}}/\overline{\text{PME}}$ interrupt due to printer port's IRQ. 1 : Enable the generation of an $\overline{\text{SMI}}/\overline{\text{PME}}$ interrupt due to printer port's IRQ.
2	FDCIRQEN. 0 : Disable the generation of an $\overline{\text{SMI}}/\overline{\text{PME}}$ interrupt due to FDC's IRQ. 1 : Enable the generation of an $\overline{\text{SMI}}/\overline{\text{PME}}$ interrupt due to FDC's IRQ.
1	URAIIRQEN. 0 : Disable the generation of an $\overline{\text{SMI}}/\overline{\text{PME}}$ interrupt due to UART A's IRQ. 1 : Enable the generation of an $\overline{\text{SMI}}/\overline{\text{PME}}$ interrupt due to UART A's IRQ.
0	URBIIRQEN. 0 : Disable the generation of an $\overline{\text{SMI}}/\overline{\text{PME}}$ interrupt due to UART B's IRQ. 1 : Enable the generation of an $\overline{\text{SMI}}/\overline{\text{PME}}$ interrupt due to UART B's IRQ.

CRF7 (Default 0x00)

Bit	Description
7 - 6	Reserved. Return zero when read
5 - 0	Enable bits of the $\overline{\text{SMI}}/\overline{\text{PME}}$ generation due to the GPIO IRQ function or device's IRQ.
5	HMIRQEN. 0 : Disable the generation of an $\overline{\text{SMI}}/\overline{\text{PME}}$ interrupt due to hardware monitor's IRQ. 1 : Enable the generation of an $\overline{\text{SMI}}/\overline{\text{PME}}$ interrupt due to hardware monitor's IRQ.
4	WDTIRQEN. 0 : Disable the generation of an $\overline{\text{SMI}}/\overline{\text{PME}}$ interrupt due to watch dog timer's IRQ. 1 : Enable the generation of an $\overline{\text{SMI}}/\overline{\text{PME}}$ interrupt due to watch dog timer's IRQ.
3	CIRIRQEN. 0 : Disable the generation of an $\overline{\text{SMI}}/\overline{\text{PME}}$ interrupt due to CIR's IRQ. 1 : Enable the generation of an $\overline{\text{SMI}}/\overline{\text{PME}}$ interrupt due to CIR's IRQ
2	MIDIIRQEN. 0 : Disable the generation of an $\overline{\text{SMI}}/\overline{\text{PME}}$ interrupt due to MIDI's IRQ. 1 : Enable the generation of an $\overline{\text{SMI}}/\overline{\text{PME}}$ interrupt due to MIDI's IRQ.
1	IRQIN1EN. 0 : Disable the generation of an $\overline{\text{SMI}}/\overline{\text{PME}}$ interrupt due to IRQIN1's IRQ. 1 : Enable the generation of an $\overline{\text{SMI}}/\overline{\text{PME}}$ interrupt due to IRQIN1's IRQ.

0	<p>IRQIN0EN.</p> <p>0 : Disable the generation of an $\overline{\text{SMI}}/\overline{\text{PME}}$ interrupt due to IRQIN0's IRQ.</p> <p>1 : Enable the generation of an $\overline{\text{SMI}}/\overline{\text{PME}}$ interrupt due to IRQIN0's IRQ.</p>
---	---

CRF9 (Default 0x00)

Bit	Description
7 - 3	Reserved. Return zero when read.
2	<p>PME_EN : Select the power management events to be either an $\overline{\text{PME}}$ or $\overline{\text{SMI}}$ interrupt for the IRQ events. Note that : this bit is valid only when SMIPME_OE = 1.</p> <p>0 : The power management events will generate an $\overline{\text{SMI}}$ event</p> <p>1 : The power management events will generate an $\overline{\text{PME}}$ event.</p>
1	Reserved.
0	<p>SMIPME_OE : This is the $\overline{\text{SMI}}$ and $\overline{\text{PME}}$ output enable bit.</p> <p>0 : Neither $\overline{\text{SMI}}$ nor $\overline{\text{PME}}$ will be generated. Only the IRQ status bit is set.</p> <p>1 : An $\overline{\text{SMI}}$ or $\overline{\text{PME}}$ event will be generated.</p>

CRFE, FF (Default 0x00)

Reserved for Winbond test.

11.13 Logical Device B (Hardware Monitor)**CR30 (Default 0x00)**

Bit	Description
7 - 1	Reserved.
0	<p>Logic device activation control</p> <p>1 : Active</p> <p>0 : Inactived</p>

CR60, CR 61 (Default 0x00, 0x00)

These two registers select Hardware Monitor base address [0x100 : 0xFFFF] on 8-byte boundary.

CR70 (Default 0x00)

Bit	Description
7 - 4	Reserved.
3 - 0	These bits select IRQ resource for Hardware Monitor.

CRF0 (Default 0x00)

Bit	Description
7 - 1	Reserved.
0	Disable initial abnormal beep (VcoreA and +3.3 V) 0 : Enable power-on abnormal beep 1 : Disable power-on abnormal beep



12. SPECIFICATIONS

12.1 Absolute Maximum Ratings

PARAMETER	RATING	UNIT
Power Supply Voltage (5V)	5V \pm 5%,	V
Input Voltage	-0.5 to V _{DD} +0.5	V
RTC Battery Voltage V _{BAT}	2.2 to 4.0	V
Operating Temperature	0 to +70	°C
Storage Temperature	-55 to +150	°C

Note : Exposure to conditions beyond those listed under Absolute Maximum Ratings may adversely affect the life and reliability of the device.

12.2 DC CHARACTERISTICS

(T_a = 0° C to 70° C, V_{DD} = 5V \pm 10%, V_{SS} = 0V)

PARAMETER	SYM.	MIN.	TYP.	MAX.	UNIT	CONDITIONS
RTC Battery Quiescent Current	IBAT			2.0	uA	V _{BAT} = 2.5 V CASEOPEN# Pull-up to V _{BAT}
ACPI Stand-by Power Supply Quiescent Current	ISB			2.0	mA	V _{BAT} = 2.5 V V _{SB} = 5.0 V CASEOPEN# Pull-up to V _{BAT}
VCC Quiescent Current	IVCC			20	mA	V _{BAT} = 2.5 V V _{SB} = 5.0 V CASEOPEN# Pull-up to V _{BAT} V _{CC} (AVCC) = 5V LRESET = High CLKIN = 48MHz
I/O_{8t} - TTL level bi-directional pin with 8mA source-sink capability						
Input Low Voltage	V _{IL}			0.8	V	
Input High Voltage	V _{IH}	2.0			V	
Output Low Voltage	V _{OL}			0.4	V	I _{OL} = 8 mA
Output High Voltage	V _{OH}	2.4			V	I _{OH} = - 8 mA
Input High Leakage	I _{LIH}			+10	μA	V _{IN} = 5V
Input Low Leakage	I _{LIL}			-10	μA	V _{IN} = 0V

PARAMETER	SYM.	MIN.	TYP.	MAX.	UNIT	CONDITIONS
I/O_{12t} - TTL level bi-directional pin with 12mA source-sink capability						
Input Low Voltage	V _{IL}			0.8	V	
Input High Voltage	V _{IH}	2.0			V	
Output Low Voltage	V _{OL}			0.4	V	I _{OL} = 12 mA
Output High Voltage	V _{OH}	2.4			V	I _{OH} = -12 mA
Input High Leakage	I _{LIH}			+10	μA	V _{IN} = 5V
Input Low Leakage	I _{LIL}			-10	μA	V _{IN} = 0V
PARAMETER	SYM.	MIN.	TYP.	MAX.	UNIT	CONDITIONS
I/O_{24t} - TTL level bi-directional pin with 24mA source-sink capability						
Input Low Voltage	V _{IL}			0.8	V	
Input High Voltage	V _{IH}	2.0			V	
Output Low Voltage	V _{OL}			0.4	V	I _{OL} = 24 mA
Output High Voltage	V _{OH}	2.4			V	I _{OH} = -24 mA
Input High Leakage	I _{LIH}			+10	μA	V _{IN} = 5V
Input Low Leakage	I _{LIL}			-10	μA	V _{IN} = 0V
I/O_{12tp3} - 3.3V TTL level bi-directional pin with 12mA source-sink capability						
Input Low Voltage	V _{IL}			0.8	V	
Input High Voltage	V _{IH}	2.0			V	
Output Low Voltage	V _{OL}			0.4	V	I _{OL} = 12 mA
Output High Voltage	V _{OH}	2.4			V	I _{OH} = -12 mA
Input High Leakage	I _{LIH}			+10	μA	V _{IN} = 3.3V
Input Low Leakage	I _{LIL}			-10	μA	V _{IN} = 0V
I/O_{12ts} - TTL level Schmitt-trigger bi-directional pin with 12mA source-sink capability						
Input Low Threshold Voltage	V _{t-}	0.5	0.8	1.1	V	
Input High Threshold Voltage	V _{t+}	1.6	2.0	2.4	V	
Hysteresis	V _{TH}	0.5	1.2		V	V _{DD} =5V
Output Low Voltage	V _{OL}			0.4	V	I _{OL} = 12 mA
Output High Voltage	V _{OH}	2.4			V	I _{OH} = -12 mA
Input High Leakage	I _{LIH}			+10	μA	V _{IN} = 5V
Input Low Leakage	I _{LIL}			-10	μA	V _{IN} = 0V
I/O_{24ts} - TTL level Schmitt-trigger bi-directional pin with 24mA source-sink capability						

PARAMETER	SYM.	MIN.	TYP.	MAX.	UNIT	CONDITIONS
Input Low Threshold Voltage	V _{t-}	0.5	0.8	1.1	V	
Input High Threshold Voltage	V _{t+}	1.6	2.0	2.4	V	
Hysteresis	V _{TH}	0.5	1.2		V	V _{DD} =5V
Output Low Voltage	V _{OL}			0.4	V	I _{OL} = 24 mA
Output High Voltage	V _{OH}	2.4			V	I _{OH} = -24 mA
Input High Leakage	I _{LIH}			+10	μA	V _{IN} = 5V
PARAMETER	SYM.	MIN.	TYP.	MAX.	UNIT	CONDITIONS
Input Low Leakage	I _{LIL}			-10	μA	V _{IN} = 0V
I/O_{24tsp3} – 3.3V TTL level Schmitt-trigger bi-directional pin with 24mA source-sink capability						
Input Low Threshold Voltage	V _{t-}	0.5	0.8	1.1	V	
Input High Threshold Voltage	V _{t+}	1.6	2.0	2.4	V	
Hysteresis	V _{TH}	0.5	1.2		V	V _{DD} =3.3V
Output Low Voltage	V _{OL}			0.4	V	I _{OL} = 24 mA
Output High Voltage	V _{OH}	2.4			V	I _{OH} = -24 mA
Input High Leakage	I _{LIH}			+10	μA	V _{IN} = 3.3V
Input Low Leakage	I _{LIL}			-10	μA	V _{IN} = 0V
I/OD_{12t} - TTL level bi-directional pin and open-drain output with 12mA sink capability						
Input Low Voltage	V _{IL}			0.8	V	
Input High Voltage	V _{IH}	2.0			V	
Output Low Voltage	V _{OL}			0.4	V	I _{OL} = 12 mA
Input High Leakage	I _{LIH}			+10	μA	V _{IN} = 5V
Input Low Leakage	I _{LIL}			-10	μA	V _{IN} = 0V
I/OD_{24t} - TTL level bi-directional pin and open-drain output with 24mA sink capability						
Input Low Voltage	V _{IL}			0.8	V	
Input High Voltage	V _{IH}	2.0			V	
Output Low Voltage	V _{OL}			0.4	V	I _{OL} = 24 mA
Input High Leakage	I _{LIH}			+10	μA	V _{IN} = 5V
Input Low Leakage	I _{LIL}			-10	μA	V _{IN} = 0V

PARAMETER	SYM.	MIN.	TYP.	MAX.	UNIT	CONDITIONS
I/OD_{12ts} - TTL level Schmitt-trigger bi-directional pin and open drain output with 12mA sink capability						
Input Low Threshold Voltage	V _{t-}	0.5	0.8	1.1	V	
Input High Threshold Voltage	V _{t+}	1.6	2.0	2.4	V	
Hysteresis	V _{TH}	0.5	1.2		V	V _{DD} =5V
Output Low Voltage	V _{OL}			0.4	V	I _{OL} = 12 mA
Input High Leakage	I _{LIH}			+10	μA	V _{IN} = 5V
Input Low Leakage	I _{LIL}			-10	μA	V _{IN} = 0V
PARAMETER	SYM.	MIN.	TYP.	MAX.	UNIT	CONDITIONS
I/OD_{24ts} - TTL level Schmitt-trigger bi-directional pin and open drain output with 24mA sink capability						
Input Low Threshold Voltage	V _{t-}	0.5	0.8	1.1	V	
Input High Threshold Voltage	V _{t+}	1.6	2.0	2.4	V	
Hysteresis	V _{TH}	0.5	1.2		V	V _{DD} =5V
Output Low Voltage	V _{OL}			0.4	V	I _{OL} = 24 mA
Input High Leakage	I _{LIH}			+10	μA	V _{IN} = 5V
Input Low Leakage	I _{LIL}			-10	μA	V _{IN} = 0V
I/OD_{12cs} - CMOS level Schmitt-trigger bi-directional pin and open drain output with 12mA sink capability						
Input Low Threshold Voltage	V _{t-}	1.3	1.5	1.7	V	V _{DD} = 5 V
Input High Threshold Voltage	V _{t+}	3.2	3.5	3.8	V	V _{DD} = 5 V
Hysteresis	V _{TH}	1.5	2		V	V _{DD} = 5 V
Output Low Voltage	V _{OL}			0.4	V	I _{OL} = 12 mA
Input High Leakage	I _{LIH}			+10	μA	V _{IN} = 5V
Input Low Leakage	I _{LIL}			-10	μA	V _{IN} = 0 V
I/OD_{16cs} - CMOS level Schmitt-trigger bi-directional pin and open drain output with 16mA sink capability						
Input Low Threshold Voltage	V _{t-}	1.3	1.5	1.7	V	V _{DD} = 5 V

PARAMETER	SYM.	MIN.	TYP.	MAX.	UNIT	CONDITIONS
Input High Threshold Voltage	V _{t+}	3.2	3.5	3.8	V	V _{DD} = 5 V
Hysteresis	V _{TH}	1.5	2		V	V _{DD} = 5 V
Output Low Voltage	V _{OL}			0.4	V	I _{OL} = 16 mA
Input High Leakage	I _{LIH}			+10	μA	V _{IN} = 5V
Input Low Leakage	I _{LIL}			-10	μA	V _{IN} = 0 V
I/OD₁₂_{CSD} - CMOS level Schmitt-trigger bi-directional pin with internal pull down resistor and open drain output with 12mA sink capability						
Input Low Threshold Voltage	V _{t-}	1.3	1.5	1.7	V	V _{DD} = 5 V
Input High Threshold Voltage	V _{t+}	3.2	3.5	3.8	V	V _{DD} = 5 V
PARAMETER	SYM.	MIN.	TYP.	MAX.	UNIT	CONDITIONS
Hysteresis	V _{TH}	1.5	2		V	V _{DD} = 5 V
Output Low Voltage	V _{OL}			0.4	V	I _{OL} = 12 mA
Input High Leakage	I _{LIH}			+10	μA	V _{IN} = 5V
Input Low Leakage	I _{LIL}			-10	μA	V _{IN} = 0 V
I/OD₁₂_{CSU} - CMOS level Schmitt-trigger bi-directional pin with internal pull up resistor and open drain output with 12mA sink capability						
Input Low Threshold Voltage	V _{t-}	1.3	1.5	1.7	V	V _{DD} = 5 V
Input High Threshold Voltage	V _{t+}	3.2	3.5	3.8	V	V _{DD} = 5 V
Hysteresis	V _{TH}	1.5	2		V	V _{DD} = 5 V
Output Low Voltage	V _{OL}			0.4	V	I _{OL} = 12 mA
Input High Leakage	I _{LIH}			+10	μA	V _{IN} = 5V
Input Low Leakage	I _{LIL}			-10	μA	V _{IN} = 0 V
O₄ - Output pin with 4mA source-sink capability						
Output Low Voltage	V _{OL}			0.4	V	I _{OL} = 4 mA
Output High Voltage	V _{OH}	2.4			V	I _{OH} = -4 mA
O₈ - Output pin with 8mA source-sink capability						
Output Low Voltage	V _{OL}			0.4	V	I _{OL} = 8 mA
Output High Voltage	V _{OH}	2.4			V	I _{OH} = -8 mA
O₁₂ - Output pin with 12mA source-sink capability						

PARAMETER	SYM.	MIN.	TYP.	MAX.	UNIT	CONDITIONS
Output Low Voltage	V _{OL}			0.4	V	I _{OL} = 12 mA
Output High Voltage	V _{OH}	2.4			V	I _{OH} = -12 mA
O16 - Output pin with 16mA source-sink capability						
Output Low Voltage	V _{OL}			0.4	V	I _{OL} = 16 mA
Output High Voltage	V _{OH}	2.4			V	I _{OH} = -16 mA

PARAMETER	SYM.	MIN.	TYP.	MAX.	UNIT	CONDITIONS
O₂₄ - Output pin with 24mA source-sink capability						
Output Low Voltage	V _{OL}			0.4	V	I _{OL} = 24 mA
Output High Voltage	V _{OH}	2.4			V	I _{OH} = -24 mA
O_{12p3} - 3.3V output pin with 12mA source-sink capability						
Output Low Voltage	V _{OL}			0.4	V	I _{OL} = 12 mA
O_{24p3} - 3.3V output pin with 24mA source-sink capability						
Output Low Voltage	V _{OL}			0.4	V	I _{OL} = 24 mA
OD₁₂ - Open drain output pin with 12mA sink capability						
Output Low Voltage	V _{OL}			0.4	V	I _{OL} = 12 mA
OD₂₄ - Open drain output pin with 24mA sink capability						
Output Low Voltage	V _{OL}			0.4	V	I _{OL} = 24 mA
OD_{12p3} - 3.3V open drain output pin with 12mA sink capability						
Output Low Voltage	V _{OL}			0.4	V	I _{OL} = 12 mA
IN_t - TTL level input pin						
Input Low Voltage	V _{IL}			0.8	V	
Input High Voltage	V _{IH}	2.0			V	
Input High Leakage	I _{LIH}			+10	μA	V _{IN} = 5V
Input Low Leakage	I _{LIL}			-10	μA	V _{IN} = 0 V
IN_{tp3} - 3.3V TTL level input pin						
Input Low Voltage	V _{IL}			0.8	V	
Input High Voltage	V _{IH}	2.0			V	
Input High Leakage	I _{LIH}			+10	μA	V _{IN} = 3.3V
Input Low Leakage	I _{LIL}			-10	μA	V _{IN} = 0 V
IN_{td} - TTL level input pin with internal pull down resistor						
Input Low Voltage	V _{IL}			0.8	V	
Input High Voltage	V _{IH}	2.0			V	
Input High Leakage	I _{LIH}			+10	μA	V _{IN} = 5V
Input Low Leakage	I _{LIL}			-10	μA	V _{IN} = 0 V
IN_{tu} - TTL level input pin with internal pull up resistor						
Input Low Voltage	V _{IL}			0.8	V	

PARAMETER	SYM.	MIN.	TYP.	MAX.	UNIT	CONDITIONS
Input High Voltage	V_{IH}	2.0			V	
Input High Leakage	I_{LIH}			+10	μA	$V_{IN} = 5V$
Input Low Leakage	I_{LIL}			-10	μA	$V_{IN} = 0V$
IN_{ts}- TTL level Schmitt-trigger input pin						
Input Low Threshold Voltage	V_{t-}	0.5	0.8	1.1	V	$V_{DD} = 5V$
Input High Threshold Voltage	V_{t+}	1.6	2.0	2.4	V	$V_{DD} = 5V$
Hysteresis	V_{TH}	0.5	1.2		V	$V_{DD} = 5V$
Input High Leakage	I_{LIH}			+10	μA	$V_{IN} = 5V$
Input Low Leakage	I_{LIL}			-10	μA	$V_{IN} = 0V$
IN_{tsp3} - 3.3 V TTL level Schmitt-trigger input pin						
Input Low Threshold Voltage	V_{t-}	0.5	0.8	1.1	V	$V_{DD} = 3.3V$
Input High Threshold Voltage	V_{t+}	1.6	2.0	2.4	V	$V_{DD} = 3.3V$
Hysteresis	V_{TH}	0.5	1.2		V	$V_{DD} = 3.3V$
Input High Leakage	I_{LIH}			+10	μA	$V_{IN} = 3.3V$
Input Low Leakage	I_{LIL}			-10	μA	$V_{IN} = 0V$
IN_c- CMOS level input pin						
Input Low Voltage	V_{IL}			1.5	V	
Input High Voltage	V_{IH}	3.5			V	
Input High Leakage	I_{LIH}			+10	μA	$V_{IN} = 5V$
Input Low Leakage	I_{LIL}			-10	μA	$V_{IN} = 0V$
IN_{cd}- CMOS level input pin with internal pull down resistor						
Input Low Voltage	V_{IL}			1.5	V	
Input High Voltage	V_{IH}	3.5			V	
Input High Leakage	I_{LIH}			+10	μA	$V_{IN} = 5V$
Input Low Leakage	I_{LIL}			-10	μA	$V_{IN} = 0V$
IN_{cs}- CMOS level Schmitt-trigger input pin						
Input Low Threshold Voltage	V_{t-}	1.3	1.5	1.7	V	$V_{DD} = 5V$

PARAMETER	SYM.	MIN.	TYP.	MAX.	UNIT	CONDITIONS
Hysteresis	V _{TH}	1.5	2		V	V _{DD} = 5 V
Input High Leakage	I _{LIH}			+10	μA	V _{IN} = 5 V
Input Low Leakage	I _{LIL}			-10	μA	V _{IN} = 0 V
IN_{CSU} - CMOS level Schmitt-trigger input pin with internal pull up resistor						
Input Low Threshold Voltage	V _{t-}	1.3	1.5	1.7	V	V _{DD} = 5 V
Input High Threshold Voltage	V _{t+}	3.2	3.5	3.8	V	V _{DD} = 5 V
Hysteresis	V _{TH}	1.5	2		V	V _{DD} = 5 V
Input High Leakage	I _{LIH}			+10	μA	V _{IN} = 5V
Input Low Leakage	I _{LIL}			-10	μA	V _{IN} = 0 V

13. APPLICATION CIRCUITS

13.1 Parallel Port Extension FDD

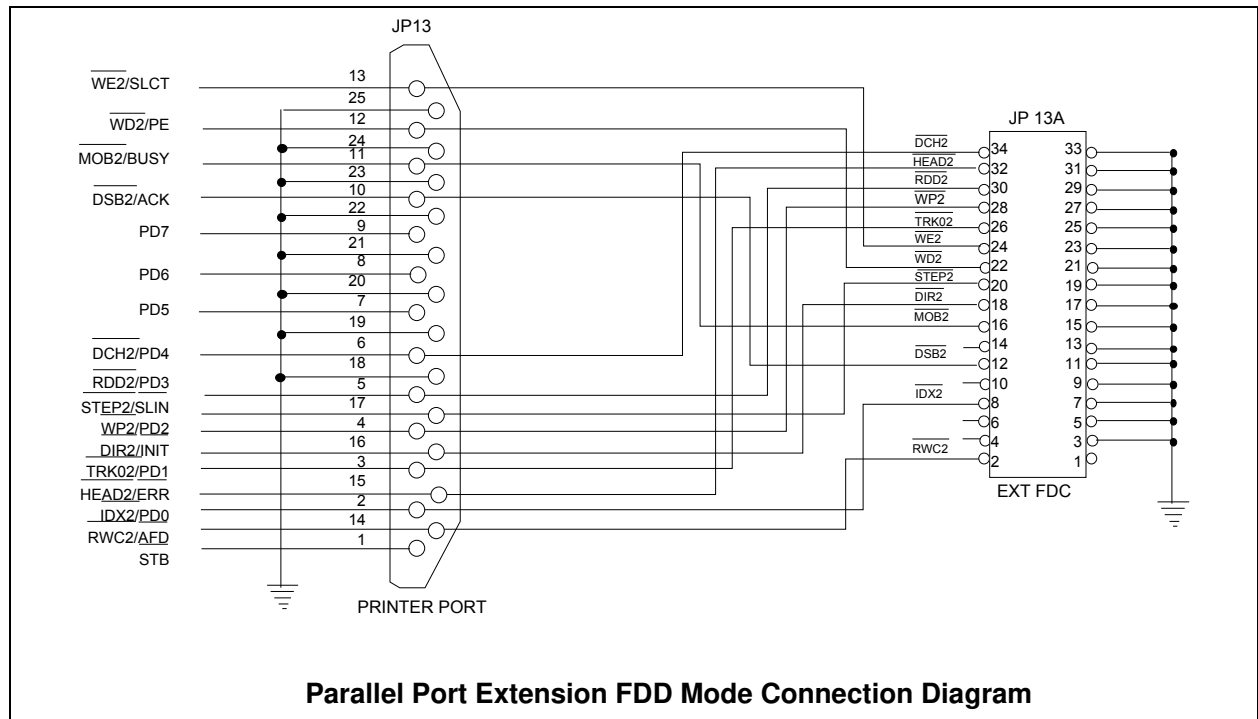

13.2 Parallel Port Extension 2FDD

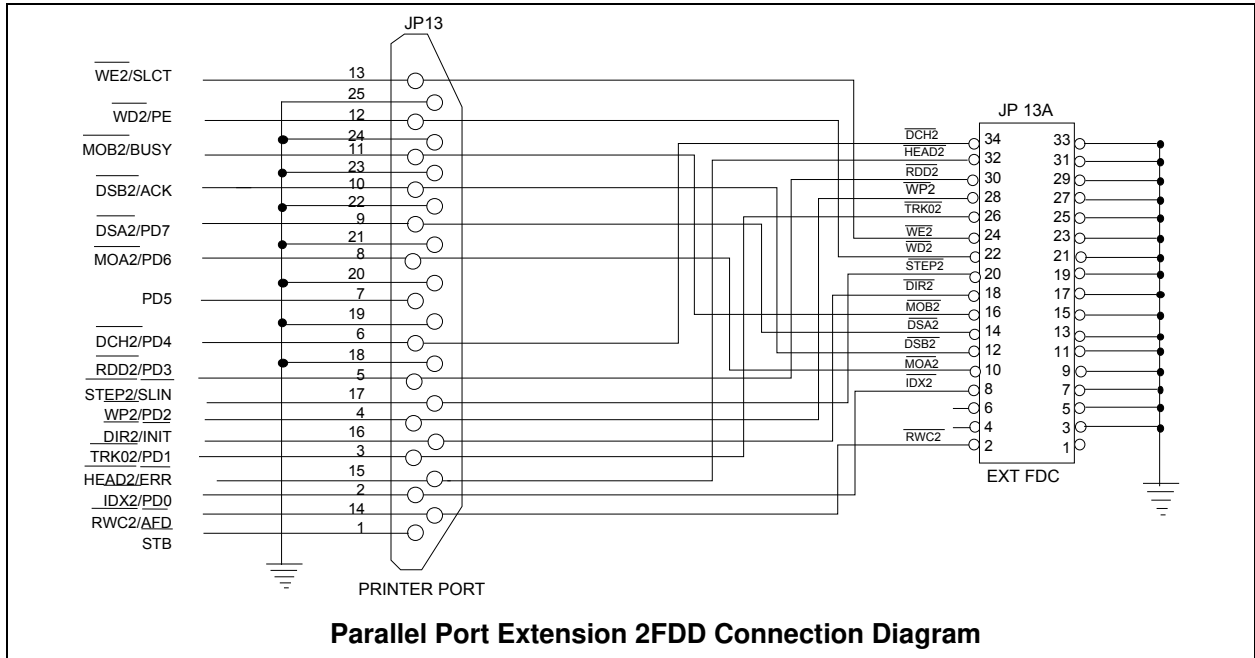

13.3 Four FDD Mode

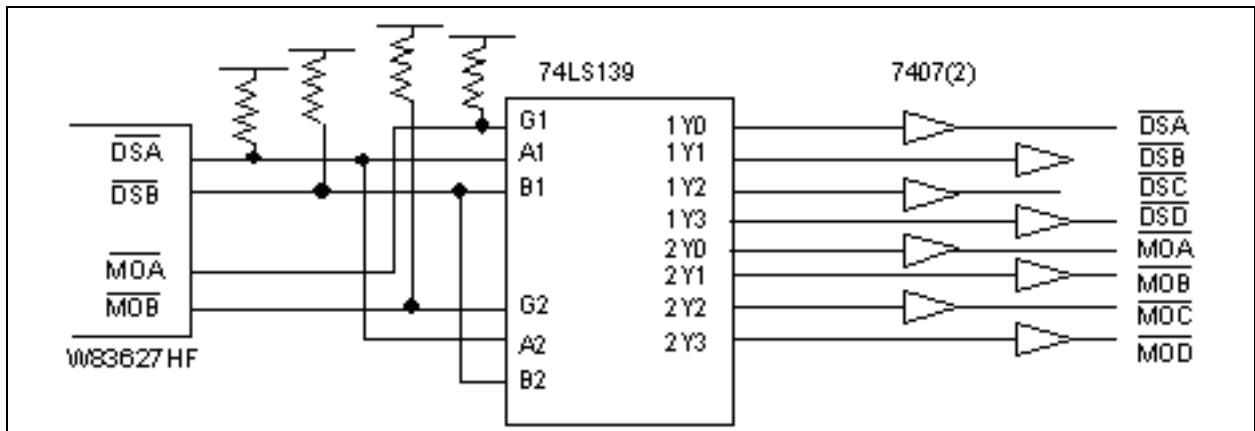

14. ORDERING INFORMATION

PART NO.	KBC FIRMWARE	REMARKS
W83627HG-AW	AMIKEY-2™	
W83627G-AW	AMIKEY-2™	EOL already

15. TOP MARKING SPECIFICATIONS



1st line : Winbond logo

2nd line : the type number : W83627HG-AW, W83627G-AW
 (the "G" means Pb-free package)

3rd line : the source of KBC F/W -- American Megatrends Incorporated™

4th line : the tracking code 821 A 2 B 282012345BC

821 : package made in '98, week 21

A : assembly house ID; A means ASE, S means SPIL.... etc.

2 : Winbond internal use

B : IC revision; A means version A, B means version B

282012345 : wafer production series lot number

BC : Winbond internal use

16. PACKAGE DIMENSIONS

128-pin (QFP, 14x20x2.75mm foot print 3.2mm)

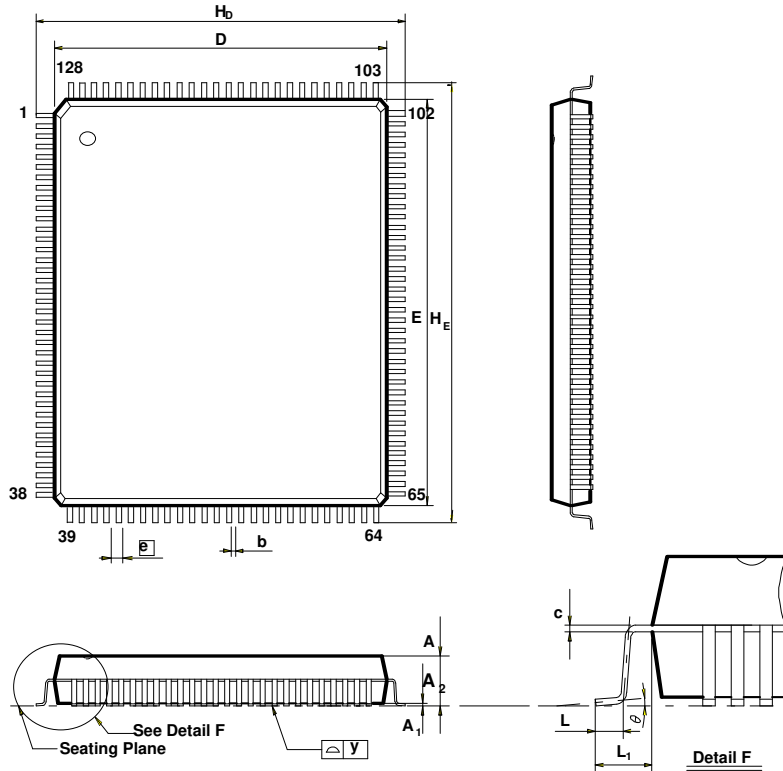

Symbol	Dimension in inch			Dimension in mm		
	Min	Nom	Max	Min	Nom	Max
A	—	—	0.134	—	—	3.40
A₁	0.004	—	—	0.10	—	—
A₂	0.101	0.107	0.113	2.57	2.72	2.87
b	0.006	0.008	0.010	0.15	0.20	0.25
c	0.004	0.006	0.010	0.10	0.15	0.25
D	0.547	0.551	0.555	13.90	14.00	14.10
E	0.783	0.787	0.791	19.90	20.00	20.10
e	—	0.020	—	—	0.50	—
H_D	0.669	0.677	0.685	17.00	17.20	17.40
H_E	0.905	0.913	0.921	23.00	23.20	23.40
L	0.023	0.031	0.039	0.60	0.80	1.00
L₁	0.055	0.063	0.071	1.40	1.60	1.80
y	—	—	0.004	—	—	0.10
θ	0°	—	12°	0°	—	12°

17. REVISION HISTORY

VERSION	DATE	PAGE	DESCRIPTION
0.50	09/25/98	N.A.	Not released For internal use only
0.51	11/10/98	88-93,102,105, 139,151,153	First published. Explanation of H/W Monitor function and register correction.
0.52	01/11/99	90-93;113-115	Pinout and register correction.
0.53	07/26/99	90,91,113-115, 119- 123,133,136, 137,140,141	Typo and data correction. H/W Monitor register explanation.
1.0	11/14/00	All	New composition.
2.0	11/01/02	All	New composition.
2.1	03/07/03	90	Correct SUSLED mode register
2.2	04/09/03	1. P74 ~ P76 2. P3,P90,P111 3. P6~P7	1. Add Section 4.1 Plug and Pla Configuration. 2. Remove Phoenix MultiKey related. 3. Add Block Digram
2.21	02/03/04	113	Add the top marking of W83627HG and W83627G.
2.22	05/28/04	12,13,21,23,39, 45,46,82,93,94, 98 ~ 100	Typo and data correction.
2.23	07/07/04	20,24,84,100	Data correction.
2.24	10/28/04	48,79	Data correction.
2.25	11/02/04	98	Data correction.
2.26	01/11/05	24, 76,77,117	Add part No.to Section 7 Ordering Instruction and data correction.
2.27	07/21/06	52	Correct Beep out frequency.
2.28	07/27/06	12	Data correction.
2.29	10/25/06	103	Add description for CRF1 in LDNA;
2.30	01/11/06	118	Correct AP circuit for PSIN

VERSION	DATE	PAGE	DESCRIPTION
2.4	03/05/07	77	Update "MR" to "LRESET".
2.5	08/28/07	All	Remove all the words and descriptions of "W83627HF/F".
2.6	11/21/07	76~84	Add Chapter 10 UART PORT
2.61	02/15/2008	52	Correct the pin numbers from 18, 19, and 20 to 111, 112 and 113.
2.62	04/23/2008	51, 115	<ol style="list-style-type: none"> 1. Update the description of bit 5 in IRQ/OVT# Property Select Register – Index 4Ch (Bank 0). 2. Update the values in 12.1 Absolute Maximum Ratings and 12.2 DC Characteristics.
2.63	04/03/2009	61, 126, 127	<ol style="list-style-type: none"> 1. Data correction. 2. Update Chapter 14, Ordering Information. 3. Update Chapter 15, Top Marking Specifications. 4. Update Chapter 16, Package Dimensions.

Important Notice

Nuvoton products are not designed, intended, authorized or warranted for use as components in systems or equipment intended for surgical implantation, atomic energy control instruments, airplane or spaceship instruments, transportation instruments, traffic signal instruments, combustion control instruments, or for other applications intended to support or sustain life. Furthermore, Nuvoton products are not intended for applications wherein failure of Nuvoton products could result or lead to a situation wherein personal injury, death or severe property or environmental damage could occur.

Nuvoton customers using or selling these products for use in such applications do so at their own risk and agree to fully indemnify Nuvoton for any damages resulting from such improper use or sales.

*Please note that all data and specifications are subject to change without notice.
All the trademarks of products and companies mentioned in this datasheet belong to their respective owners.*

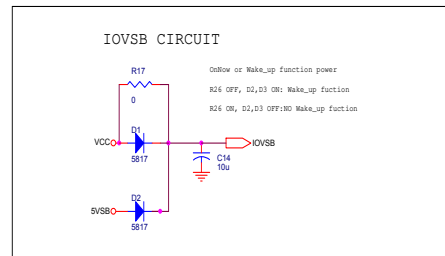
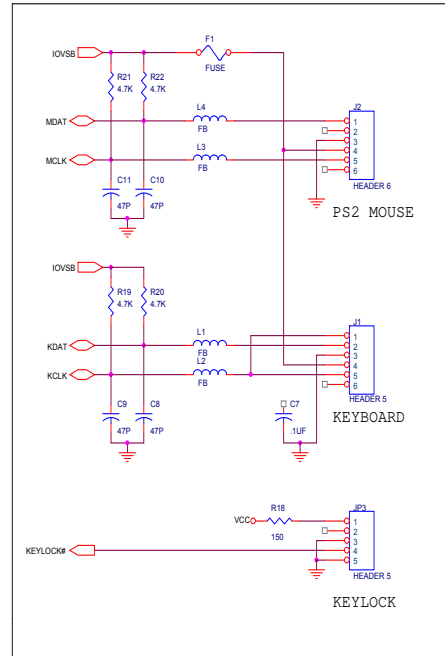
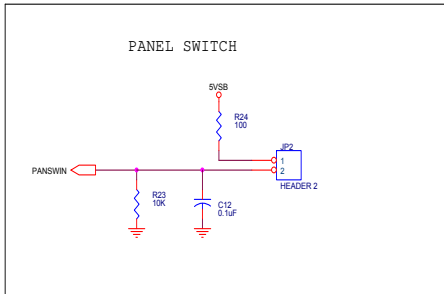
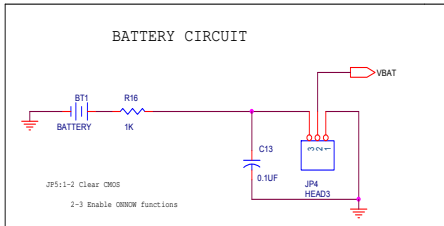
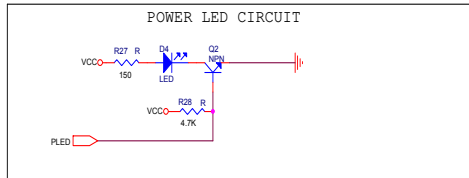
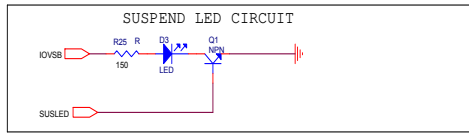

WINBOND ELECTRONICS CORP.			
File W83627HF CIRCUIT (LPC I/O + HM)			
Size	Document Number	Rev	
	Customer & PS2 MOUSE & POWER	0.4	
Date	Monday, August 05, 2002	Sheet	2 of 6



COM PORT

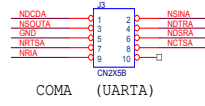
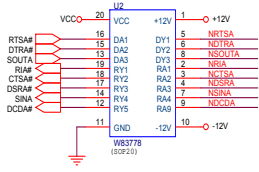

IR/CIR CONNECTOR

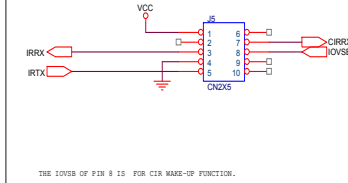

THE IOVSB OF PIN 10 IS FOR CIR WAKE-UP FUNCTION.

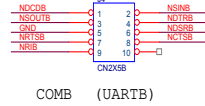
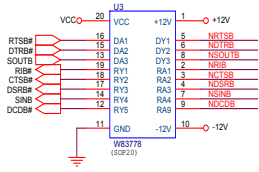

PRT PORT

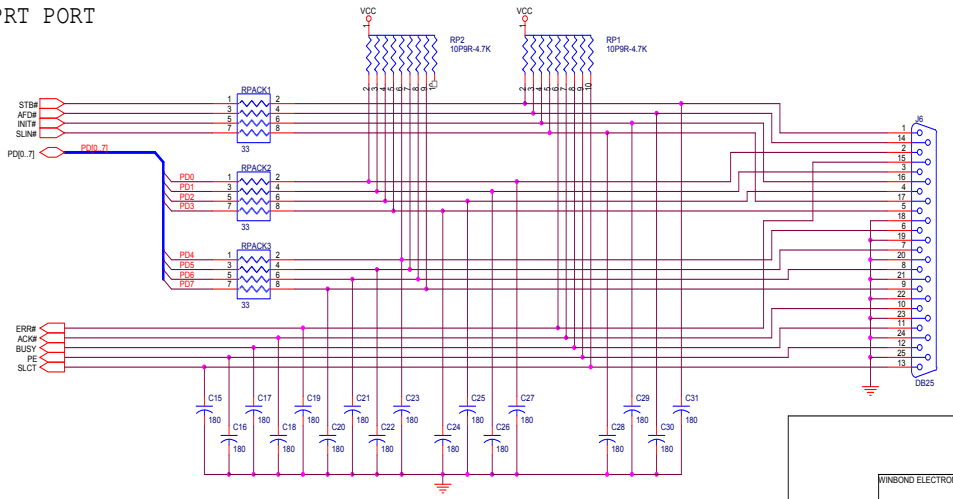

WINBOND ELECTRONICS CORP.		
File	W83627HF CIRCUIT (LPC I/O + HW)	
Size	Docament Number	Rev
	CustomCOM & IR & LPT PORT	0.4
Date	Monday, August 05, 2002	Sheet 3 of 6

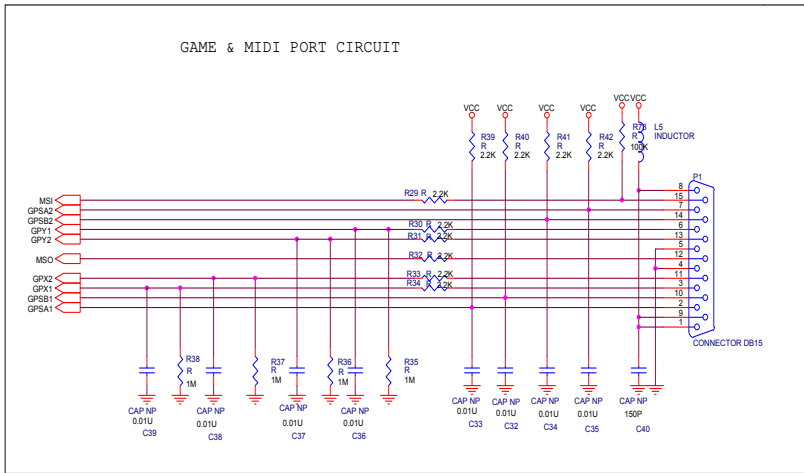

WINBOND ELECTRONICS CORP.		
File: W83627HF CIRCUIT (LPC I/O + HW)		
Size	Document Number	Rev
	Cust:prGAME & MIDI	0.4
Date:	Monday, August 05, 2002	Sheet 4 of 6

Hardware Monitor circuits

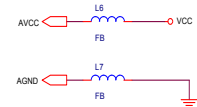
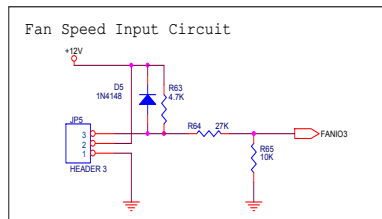
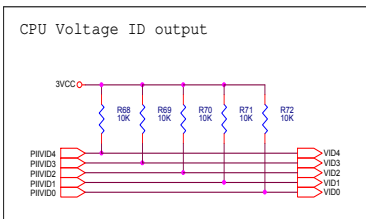
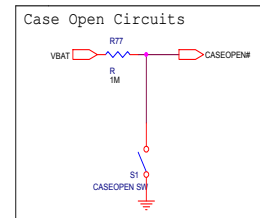
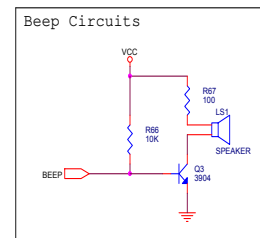
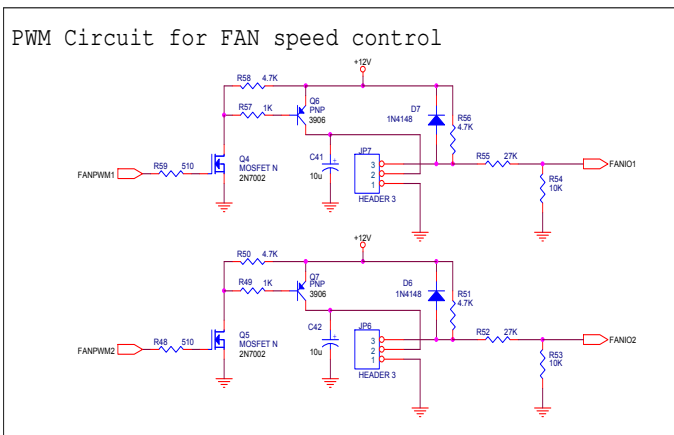
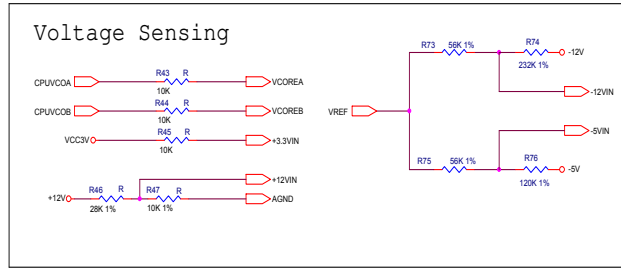
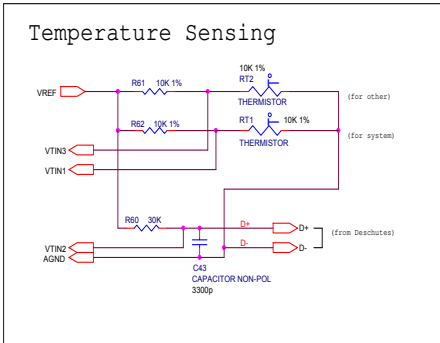

Winbond Electronic Corp.			
Title: W83627HF CIRCUIT (LPC I/O+ HW)			
Size	Document Number	Rev	
Customer	Hardware Monitor	0.4	
Date	Monday, August 05, 2002	Sheet	5 of 6